



US008259078B2

(12) **United States Patent**
Hotelling et al.

(10) **Patent No.:** **US 8,259,078 B2**

(45) **Date of Patent:** **Sep. 4, 2012**

(54) **TOUCH SCREEN LIQUID CRYSTAL DISPLAY**

(56)

References Cited

(75) Inventors: **Steve Porter Hotelling**, Los Gatos, CA (US); **Wei Chen**, Palo Alto, CA (US); **Christoph Horst Krah**, Los Altos, CA (US); **John Greer Elias**, Townsend, DE (US); **Wei Hsin Yao**, Fremont, CA (US); **John Z. Zhong**, Cupertino, CA (US); **Andrew Bert Hodge**, Palo Alto, CA (US); **Brian Richards Land**, Redwood City, CA (US); **Willem den Boer**, Brighton, MI (US)

U.S. PATENT DOCUMENTS
3,644,835 A 2/1972 Thompson
4,313,108 A 1/1982 Yoshida
4,623,757 A 11/1986 Marino
4,772,885 A 9/1988 Uehara et al.
4,916,308 A 4/1990 Meadows
(Continued)

FOREIGN PATENT DOCUMENTS
DE 197 06 168 A1 8/1998
(Continued)

(73) Assignee: **Apple Inc.**, Cupertino, CA (US)

OTHER PUBLICATIONS

(*) Notice: Subject to any disclaimer, the term of this patent is extended or adjusted under 35 U.S.C. 154(b) by 848 days.

International Search Report mailed Mar. 7, 2008, for PCT Application No. PCT/2007/70722, filed Jun. 8, 2007, three pages.

(Continued)

(21) Appl. No.: **11/760,036**

Primary Examiner — Alexander Eisen

Assistant Examiner — Patrick F Marinelli

(22) Filed: **Jun. 8, 2007**

(74) *Attorney, Agent, or Firm* — Morrison & Foerster LLP

(65) **Prior Publication Data**

US 2008/0062147 A1 Mar. 13, 2008

(57)

ABSTRACT

Related U.S. Application Data

(60) Provisional application No. 60/804,361, filed on Jun. 9, 2006, provisional application No. 60/883,979, filed on Jan. 8, 2007.

Disclosed herein are liquid-crystal display (LCD) touch screens that integrate the touch sensing elements with the display circuitry. The integration may take a variety of forms. Touch sensing elements can be completely implemented within the LCD stackup but outside the not between the color filter plate and the array plate. Alternatively, some touch sensing elements can be between the color filter and array plates with other touch sensing elements not between the plates. In another alternative, all touch sensing elements can be between the color filter and array plates. The latter alternative can include both conventional and in-plane-switching (IPS) LCDs. In some forms, one or more display structures can also have a touch sensing function. Techniques for manufacturing and operating such displays, as well as various devices embodying such displays are also disclosed.

(51) **Int. Cl.**

G06F 3/041 (2006.01)

G09G 5/00 (2006.01)

(52) **U.S. Cl.** **345/173**; 345/156

(58) **Field of Classification Search** 345/156-184, 345/87-104, 204-215, 690-699; 178/18.01-20.04
See application file for complete search history.

37 Claims, 78 Drawing Sheets

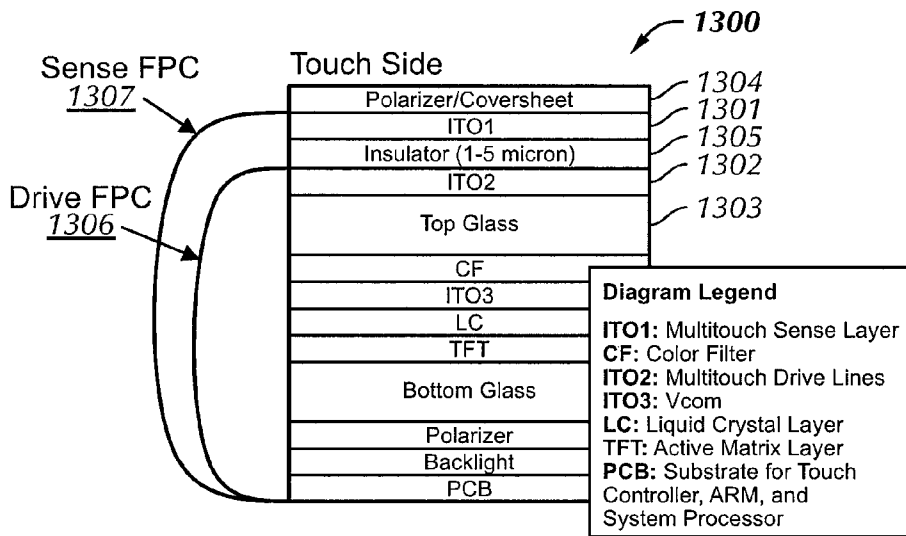

U.S. PATENT DOCUMENTS			FOREIGN PATENT DOCUMENTS			
5,062,198	A	11/1991 Sun	2002/0159015	A1	10/2002 Seo et al.	
5,105,186	A	4/1992 May	2002/0190964	A1	12/2002 Van Berkel	
5,105,288	A	4/1992 Senda et al.	2002/0192445	A1*	12/2002 Ezzell et al. 428/212	
5,353,135	A	10/1994 Edwards	2003/0174128	A1	9/2003 Matsufusa	
5,374,787	A*	12/1994 Miller et al. 178/18.06	2003/0179323	A1	9/2003 Abileah et al.	
5,392,058	A	2/1995 Tagawa	2003/0222857	A1	12/2003 Abileah	
5,459,463	A	10/1995 Gruaz et al.	2003/0234769	A1	12/2003 Cross et al.	
5,483,261	A	1/1996 Yasutake	2003/0234770	A1	12/2003 MacKey	
5,488,204	A	1/1996 Mead et al.	2004/0080501	A1	4/2004 Koyama	
5,534,892	A	7/1996 Tagawa	2004/0090429	A1	5/2004 Geaghan et al.	
5,550,659	A	8/1996 Fujieda et al.	2004/0109097	A1	6/2004 Mai	
5,563,727	A	10/1996 Larson et al.	2004/0119701	A1	6/2004 Mulligan et al.	
5,576,070	A	11/1996 Yaniv	2004/0141096	A1	7/2004 Mai	
5,648,642	A	7/1997 Miller et al.	2004/0150629	A1	8/2004 Lee	
5,677,744	A	10/1997 Yoneda et al.	2004/0155991	A1	8/2004 Lowles et al.	
5,777,596	A	7/1998 Herbert	2004/0189587	A1	9/2004 Jung et al.	
5,825,352	A	10/1998 Bisset et al.	2004/0217945	A1*	11/2004 Miyamoto et al. 345/173	
5,835,079	A	11/1998 Shieh	2004/0239650	A1	12/2004 Mackey	
5,838,308	A	11/1998 Knapp et al.	2005/0052582	A1	3/2005 Mai	
5,841,415	A	11/1998 Kwon et al.	2005/0073507	A1*	4/2005 Richter et al. 345/174	
5,847,690	A	12/1998 Boie et al.	2005/0099402	A1*	5/2005 Nakanishi et al. 345/173	
5,852,487	A	12/1998 Fujimori et al.	2005/0170668	A1	8/2005 Park et al.	
5,861,875	A	1/1999 Gerpheide	2005/0231487	A1*	10/2005 Ming 345/173	
5,867,151	A	2/1999 Nakai	2005/0243023	A1	11/2005 Reddy et al.	
5,880,411	A	3/1999 Gillespie et al.	2006/0007087	A1	1/2006 Choi et al.	
5,917,165	A	6/1999 Platt et al.	2006/0007165	A1*	1/2006 Yang et al. 345/173	
5,920,298	A	7/1999 McKnight	2006/0012575	A1*	1/2006 Knapp et al. 345/173	
5,920,309	A*	7/1999 Bisset et al. 345/173	2006/0017710	A1	1/2006 Lee et al.	
5,929,834	A	7/1999 Inoue et al.	2006/0026521	A1	2/2006 Hotelling et al.	
5,940,055	A	8/1999 Lee	2006/0097991	A1*	5/2006 Hotelling et al. 345/173	
5,945,980	A*	8/1999 Moissev et al. 345/173	2006/0132462	A1*	6/2006 Geaghan 345/173	
5,952,998	A*	9/1999 Clancy et al. 345/173	2006/0145365	A1	7/2006 Halls et al.	
6,020,945	A	2/2000 Sawai et al.	2006/0145983	A1	7/2006 Lee et al.	
6,028,581	A	2/2000 Umeya	2006/0146033	A1	7/2006 Chen et al.	
6,057,903	A	5/2000 Colgan et al.	2006/0146034	A1	7/2006 Chen et al.	
6,107,654	A*	8/2000 Yamazaki 257/194	2006/0197753	A1	9/2006 Hotelling	
6,163,313	A*	12/2000 Aroyan et al. 345/173	2006/0244736	A1	11/2006 Tseng	
6,177,918	B1	1/2001 Colgan et al.	2006/0290863	A1	12/2006 HoeSup	
6,188,391	B1	2/2001 Seely et al.	2007/0018969	A1	1/2007 Chen et al.	
6,204,897	B1	3/2001 Colgan et al.	2007/0027932	A1	2/2007 Thibeault	
6,239,788	B1	5/2001 Nohno et al.	2007/0062739	A1*	3/2007 Philipp et al. 178/18.06	
6,259,490	B1	7/2001 Colgan et al.	2007/0075977	A1	4/2007 Chen et al.	
6,285,428	B1	9/2001 Kim et al.	2007/0085838	A1	4/2007 Ricks et al.	
6,310,610	B1	10/2001 Beaton et al.	2007/0159561	A1	7/2007 Chien	
6,323,846	B1*	11/2001 Westerman et al. 345/173	2007/0176905	A1	8/2007 Shih et al.	
6,342,938	B1	1/2002 Song et al.	2007/0182706	A1	8/2007 Cassidy et al.	
6,421,039	B1	7/2002 Moon et al.	2007/0216657	A1	9/2007 Konicek	
6,483,498	B1	11/2002 Colgan et al.	2007/0257890	A1	11/2007 Hotelling et al.	
6,501,528	B1	12/2002 Hamada et al.	2007/0262967	A1	11/2007 Rho	
6,501,529	B1*	12/2002 Kurihara et al. 349/160	2008/0048994	A1	2/2008 Lee et al.	
6,549,193	B1	4/2003 Huang et al.	2008/0055221	A1	3/2008 Yabuta et al.	
6,680,448	B2	1/2004 Kawashima et al.	2008/0055268	A1	3/2008 Yoo et al.	
6,690,387	B2	2/2004 Zimmerman et al.	2008/0055270	A1	3/2008 Cho et al.	
6,876,355	B1*	4/2005 Ahn et al. 345/173	2008/0062139	A1	3/2008 Hotelling et al.	
6,906,692	B2	6/2005 Ishiyama	2008/0062140	A1	3/2008 Hotelling et al.	
6,982,432	B2	1/2006 Umemoto et al.	2008/0062148	A1	3/2008 Hotelling et al.	
7,015,894	B2	3/2006 Morohoshi	2008/0067528	A1	3/2008 Choi et al.	
7,030,860	B1	4/2006 Hsu et al.	2008/0074401	A1	3/2008 Chung et al.	
7,042,444	B2	5/2006 Cok	2008/0079697	A1	4/2008 Lee et al.	
7,098,127	B2	8/2006 Ito	2008/0129898	A1	6/2008 Moon	
7,133,032	B2	11/2006 Cok	2008/0136980	A1	6/2008 Rho et al.	
7,177,001	B2	2/2007 Lee	2008/0150901	A1	6/2008 Lowles et al.	
7,184,064	B2	2/2007 Zimmerman et al.	2008/0158167	A1	7/2008 Hotelling et al.	
7,202,856	B2	4/2007 Cok	2008/0158181	A1	7/2008 Hamblin et al.	
7,230,608	B2	6/2007 Cok	2011/0187677	A1	8/2011 Hotelling	
7,268,770	B1	9/2007 Takahata et al.				
7,280,167	B2	10/2007 Choi et al.				
7,379,054	B2	5/2008 Lee	EP	1 391 807	A1	2/2004
7,633,484	B2	12/2009 Ito	EP	1 422 601	A1	5/2004
7,705,834	B2	4/2010 Swedin	EP	1 455 264	A2	9/2004
2001/0000961	A1	5/2001 Hikida et al.	EP	1 455 264	A3	9/2004
2001/0020578	A1	9/2001 Baier	JP	07-036017	A	2/1995
2001/0020986	A1	9/2001 Ikeda et al.	JP	08-297267	A	11/1996
2001/0020987	A1	9/2001 Ahn et al.	JP	09-096792	A	4/1997
2002/0015024	A1	2/2002 Westerman et al.	JP	09-212302	A	8/1997
2002/0084922	A1	7/2002 Yagi	JP	2000-105670	A	4/2000
2002/0089496	A1	7/2002 Numao	JP	2000-163031	A	6/2000
2002/0140649	A1	10/2002 Aoyama et al.	JP	2000-172437	A	6/2000
			JP	2000-221932	A	8/2000

JP	2002-287660	A	10/2002
JP	2002-342033	A	11/2002
JP	2003-099192	A	4/2003
JP	2003-196023	A	7/2003
JP	2004-186333	A	7/2004
JP	2005-346047	A	12/2005
JP	2008-032756	A	2/2008
KR	10-0226812	B1	7/1999
KR	10-2004-0013029	A	2/2004
WO	WO 9213328	A1 *	8/1992
WO	WO-2004/023376	A2	3/2004
WO	WO-2004/023376	A3	3/2004
WO	WO-2004/053576	A1	6/2004
WO	WO-2004/114265	A2	12/2004
WO	WO-2005/114369	A2	12/2005
WO	WO-2005/114369	A3	12/2005
WO	WO-2006/054585	A1	5/2006
WO	WO-2007/146779	A2	12/2007
WO	WO-2007/146779	A3	12/2007
WO	WO-2007/146780	A2	12/2007
WO	WO-2007/146780	A3	12/2007
WO	WO-2007/146783	A2	12/2007
WO	WO-2007/146783	A3	12/2007
WO	WO-2007/146785	A2	12/2007
WO	WO-2007/146785	A3	12/2007

OTHER PUBLICATIONS

International Search Report mailed Jul. 18, 2008, for PCT Application No. PCT/2007/70725, filed Jun. 8, 2007, six pages.

International Search Report mailed Jul. 18, 2008, for PCT Application No. PCT/2007/70729, filed Jun. 8, 2007, five pages.

International Search Report mailed Mar. 6, 2008, for PCT Application No. PCT/2007/70733, filed Jun. 8, 2007, five pages.

Hector, J. et al. (May 2002). "Low Power Driving Options for an AMLCD Mobile Display Chipset," Chapter 16.3 in *SID 02 Digest* (2002 SID International Symposium, Digest of Technical Papers), XXXIII(II):694-697.

Kanda, E. et al. (2008). "55.2: Integrated Active Matrix Capacitive Sensors for Touch Panel LTPS-TFT LCDs," *SID 08 Digest*, pp. 834-837.

Lee, S.K. et al. (Apr. 1985). "A Multi-Touch Three Dimensional Touch-Sensitive Tablet," *Proceedings of CHI: ACM Conference on Human Factors in Computing Systems*, pp. 21-25.

Non-Final Office Action mailed Mar. 12, 2010, for U.S. Appl. No. 11/760,080, filed Jun. 8, 2007, 31 pages.

Non-Final Office Action mailed Apr. 23, 2010, for U.S. Appl. No. 11/760,060, filed Jun. 8, 2007, 66 pages.

Non-Final Office Action mailed May 5, 2010, for U.S. Appl. No. 11/760,049, filed Jun. 8, 2007, 65 pages.

Rubine, D.H. (Dec. 1991). "The Automatic Recognition of Gestures," CMU-CS-91-202, Submitted in Partial Fulfillment of the Requirements of the Degree of Doctor of Philosophy in Computer Science at Carnegie Mellon University, 285 pages.

Rubine, D.H. (May 1992). "Combining Gestures and Direct Manipulation," CHI '92, pp. 659-660.

Westerman, W. (Spring 1999). "Hand Tracking, Finger Identification, and Chordic Manipulation on a Multi-Touch Surface," A Dissertation Submitted to the Faculty of the University of Delaware in Partial Fulfillment of the Requirements for the Degree of Doctor of Philosophy in Electrical Engineering, 364 pages.

Partial European Search Report mailed Mar. 15, 2011, for EP Application No. 10178661.4, filed Jun. 8, 2007, six pages.

Final Office Action mailed Jul. 6, 2010, for U.S. Appl. No. 11/760,080, filed Jun. 8, 2007, 66 pages.

Final Office Action mailed Jul. 22, 2010, for U.S. Appl. No. 11/760,049, filed Jun. 8, 2007, 52 pages.

Final Office Action mailed Aug. 2, 2010, for U.S. Appl. No. 11/760,060, filed Jun. 8, 2007, 78 pages.

European Search Report mailed Jul. 28, 2011, for EP Application No. 11159164.0, filed Jun. 8, 2007, eight pages.

Non-Final Office Action mailed Aug. 11, 2011, for U.S. Appl. No. 11/760,049, filed Jun. 8, 2007, 60 pages.

Non-Final Office Action mailed Sep. 1, 2011, for U.S. Appl. No. 11/760,060, filed Jun. 8, 2007, 76 pages.

Non-Final Office Action mailed Nov. 14, 2011, for U.S. Appl. No. 11/760,080, filed Jun. 8, 2007, 60 pages.

Partial European Search Report mailed Oct. 21, 2011, for EP Application No. 11159165.7 filed Jun. 8, 2007, seven pages.

Partial European Search Report mailed Oct. 24, 2011, for EP Application No. 11159167.3 filed Jun. 8, 2007, eight pages.

Final Office Action mailed Jan. 30, 2012, for U.S. Appl. No. 11/760,049, filed Jun. 8, 2007, 64 pages.

Final Office Action mailed Feb. 27, 2012, for U.S. Appl. No. 11/760,080, filed Jun. 8, 2007, 62 pages.

European Search Report mailed Oct. 21, 2011, for EP Application No. 11159166.5, filed Jun. 8, 2007, seven pages.

Notice of Allowance mailed Mar. 27, 2012, for U.S. Appl. No. 11/760,060, filed Jun. 8, 2007, 17 pages.

* cited by examiner

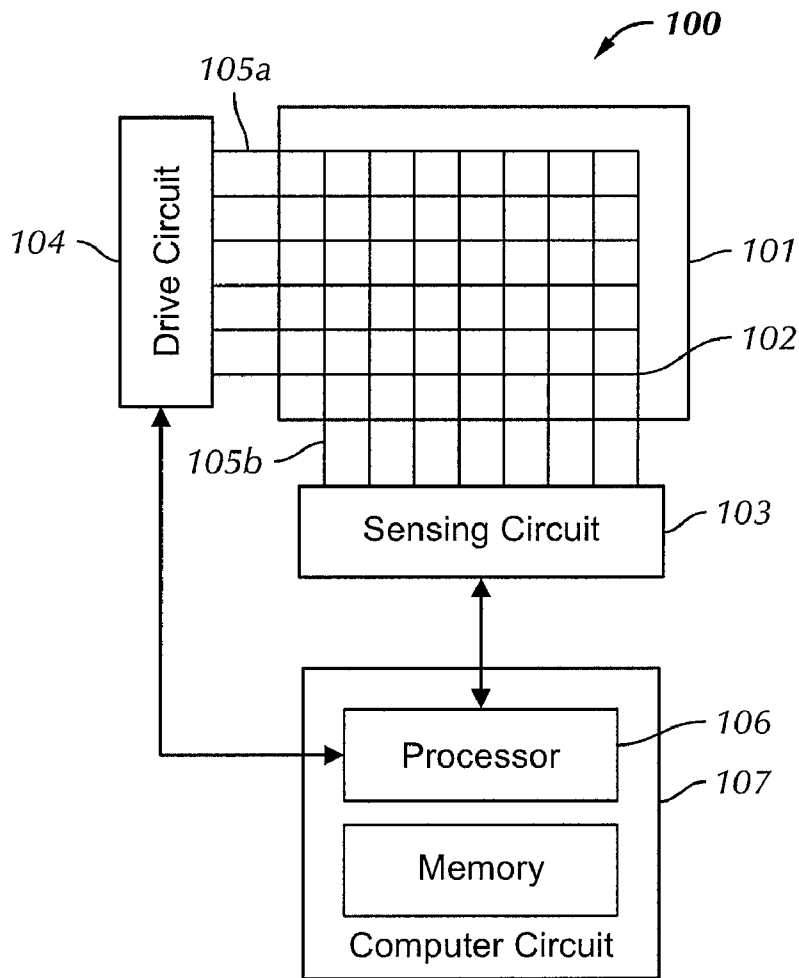

FIG. 1

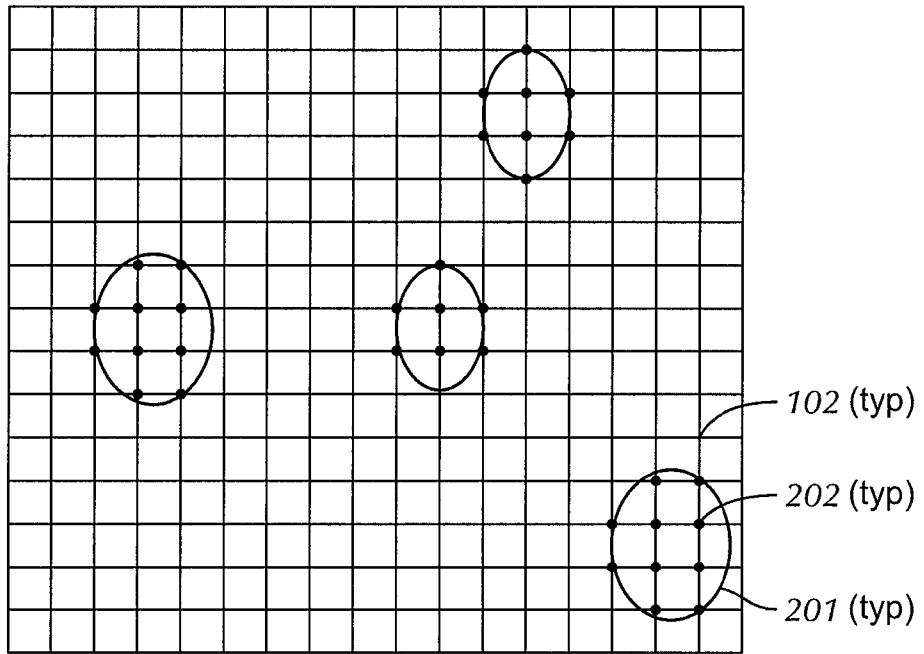

FIG. 2

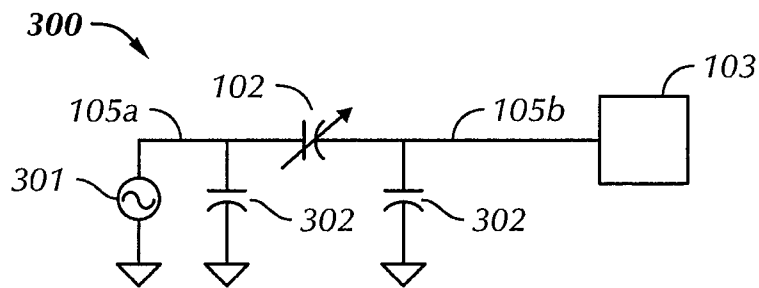

FIG. 3

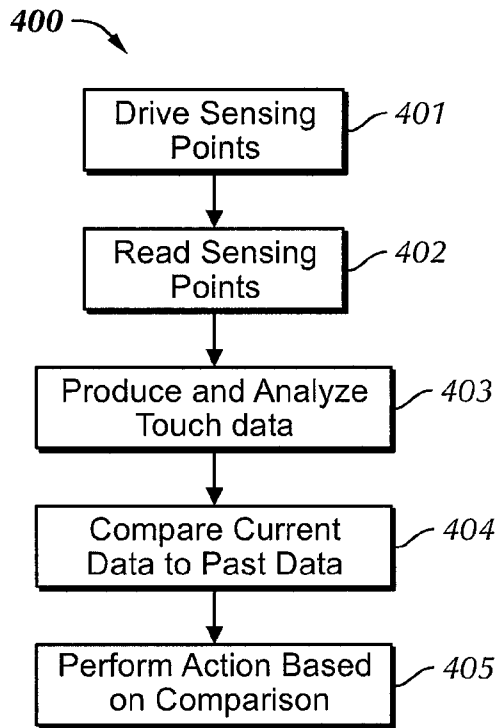

FIG. 4

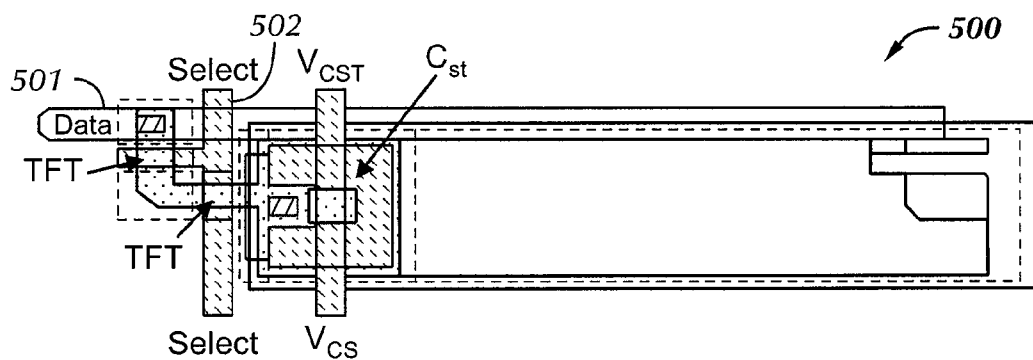

FIG. 5

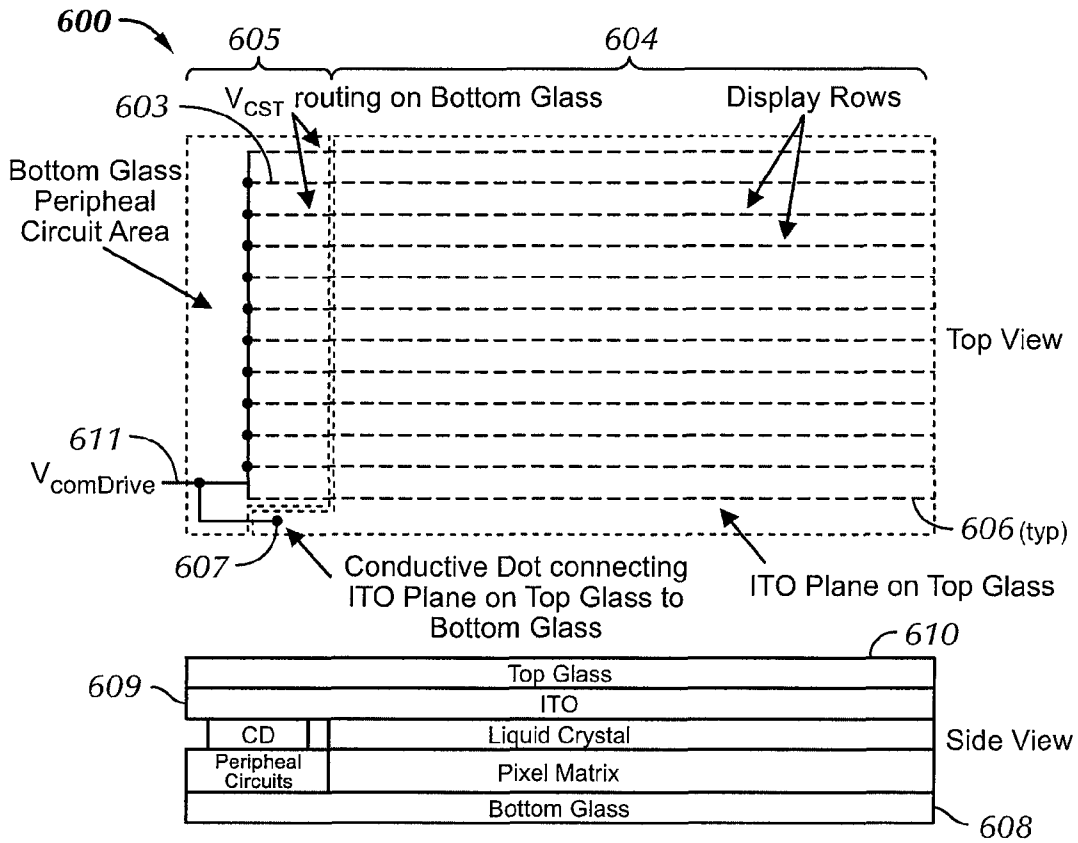

FIG. 6

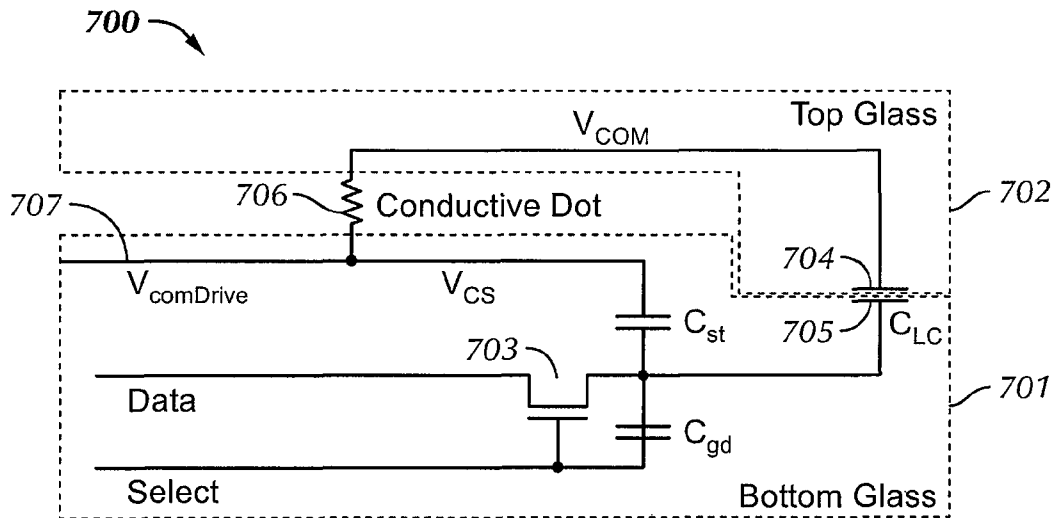

FIG. 7

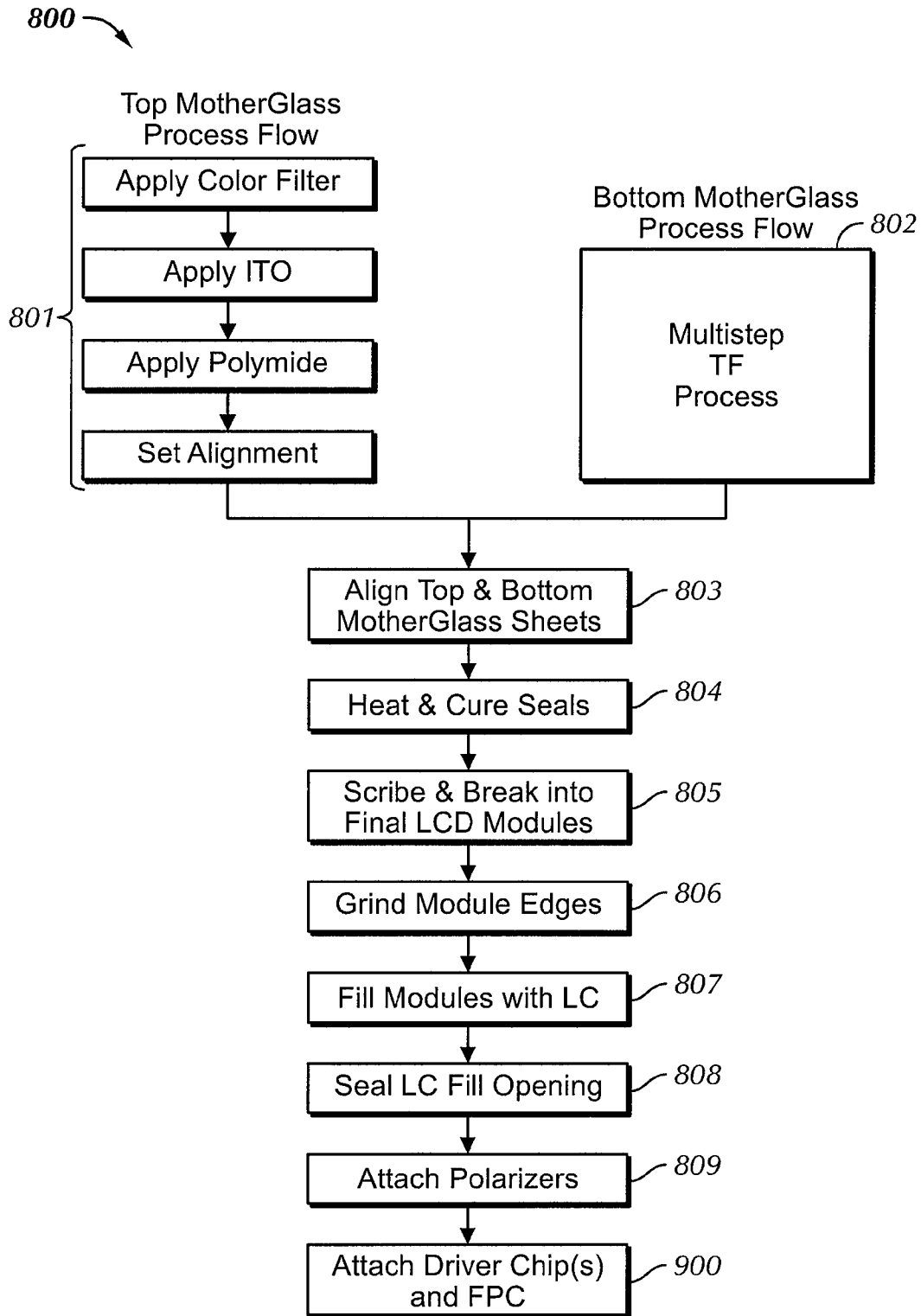

FIG. 8

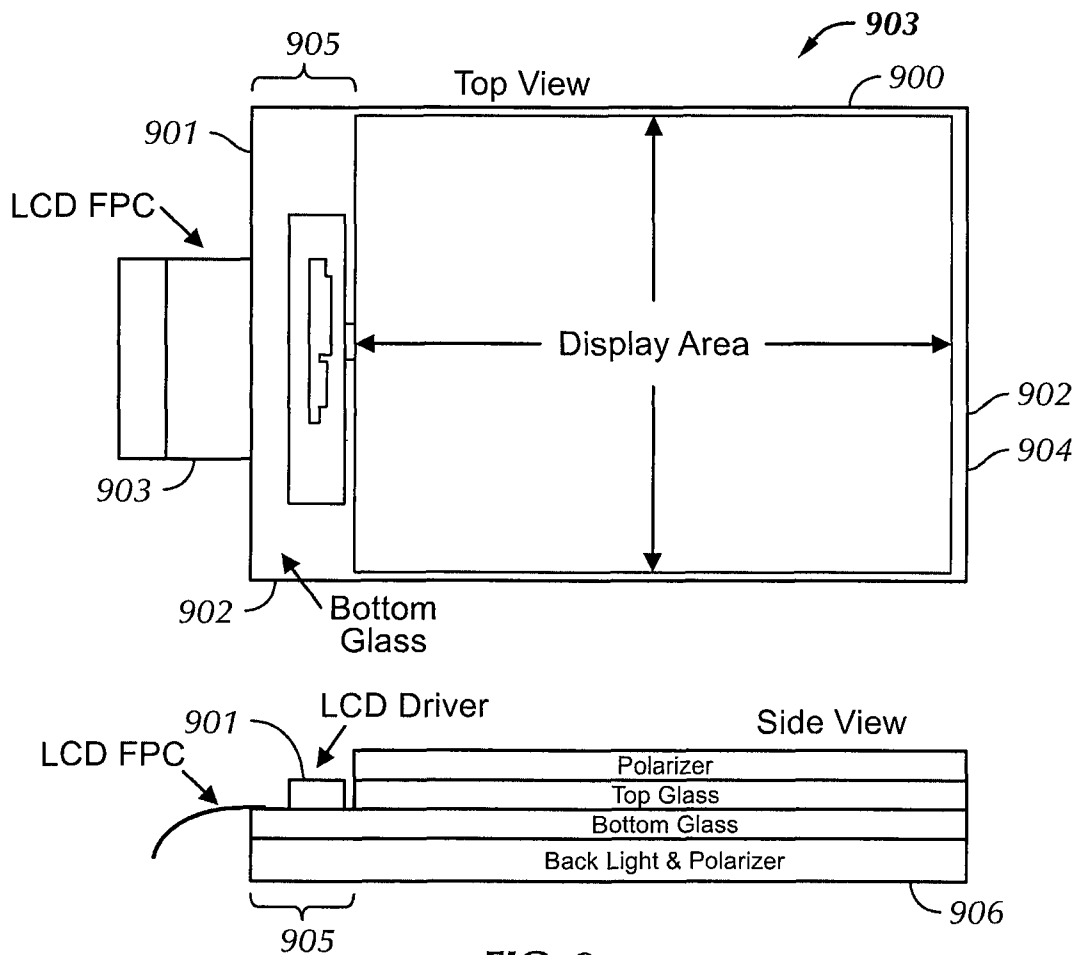

FIG. 9

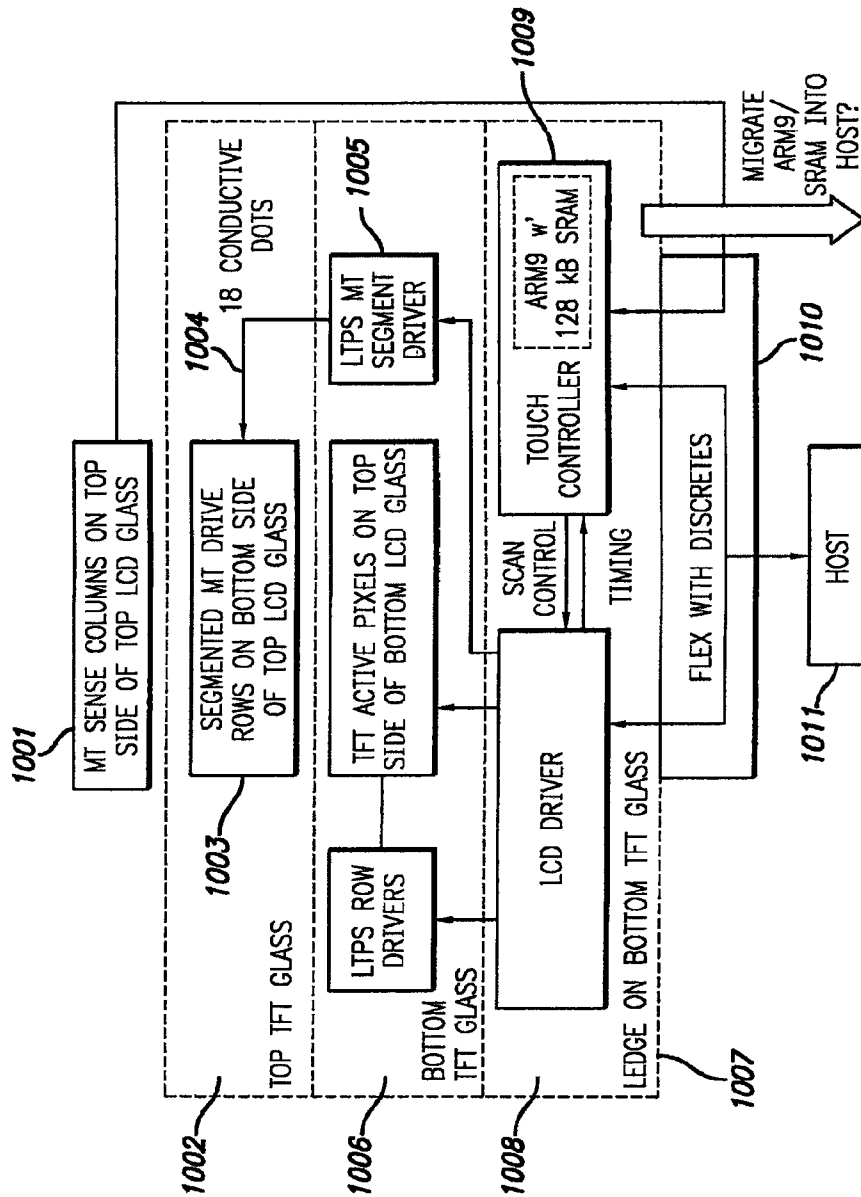

FIG. 10

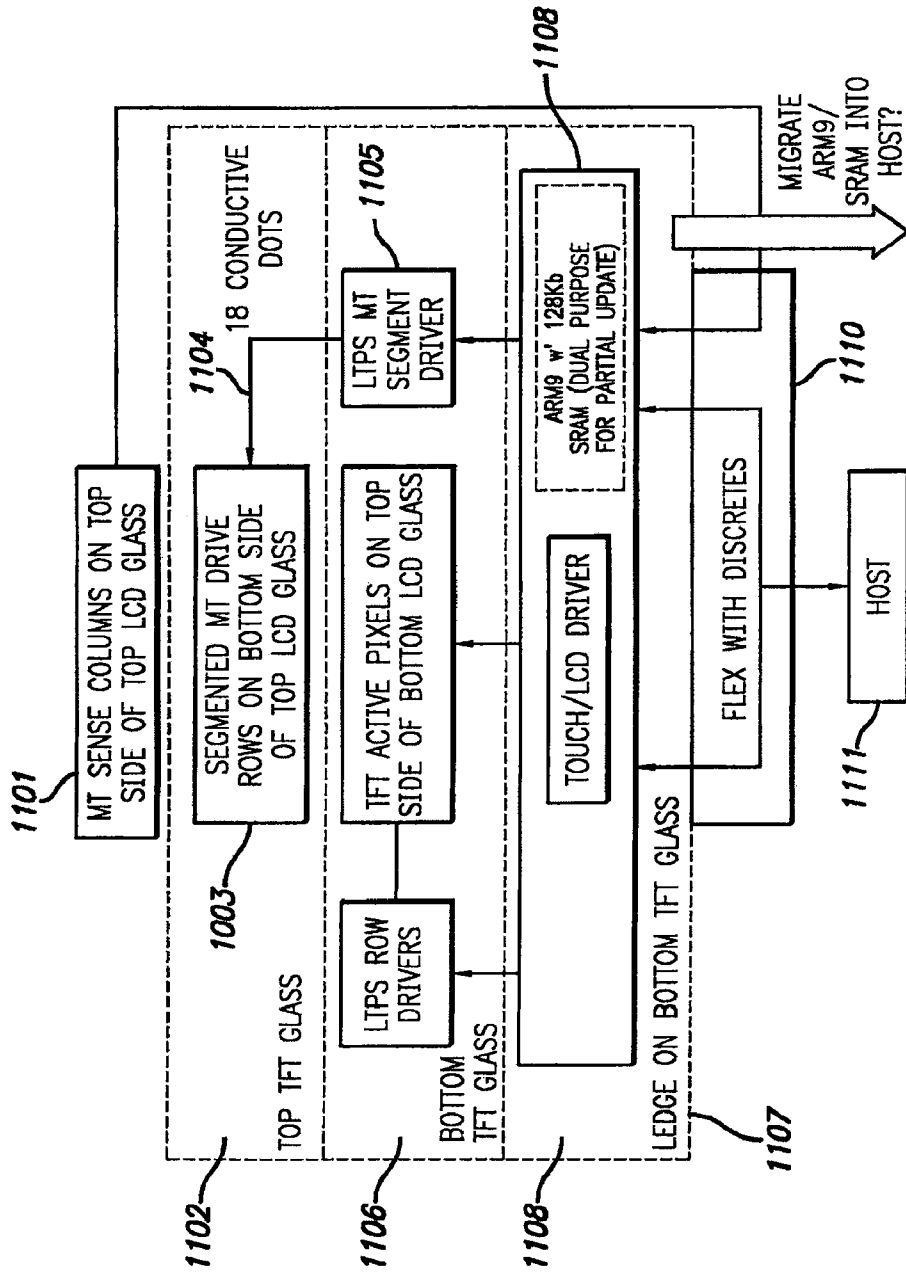

FIG. 11

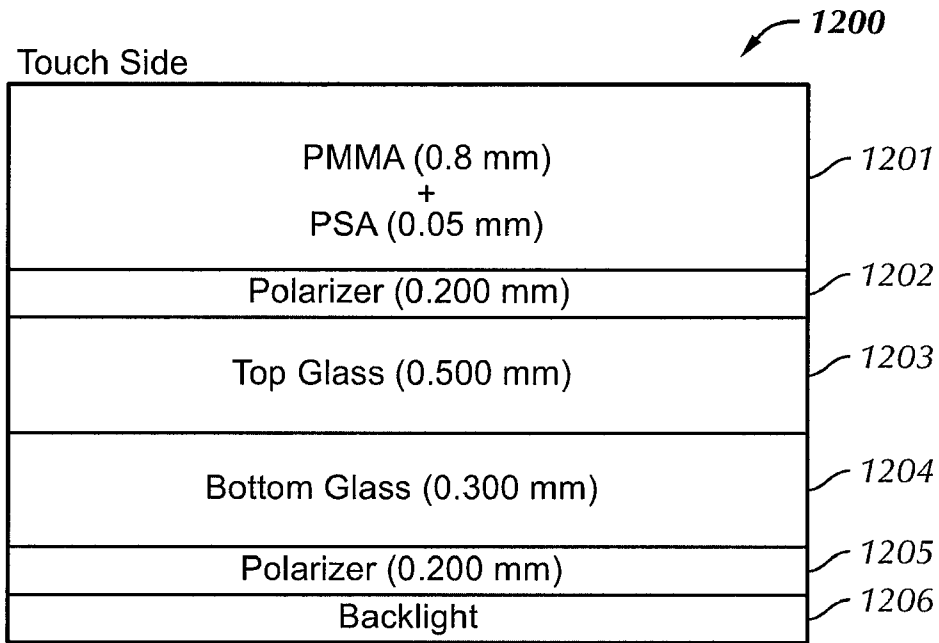

FIG. 12

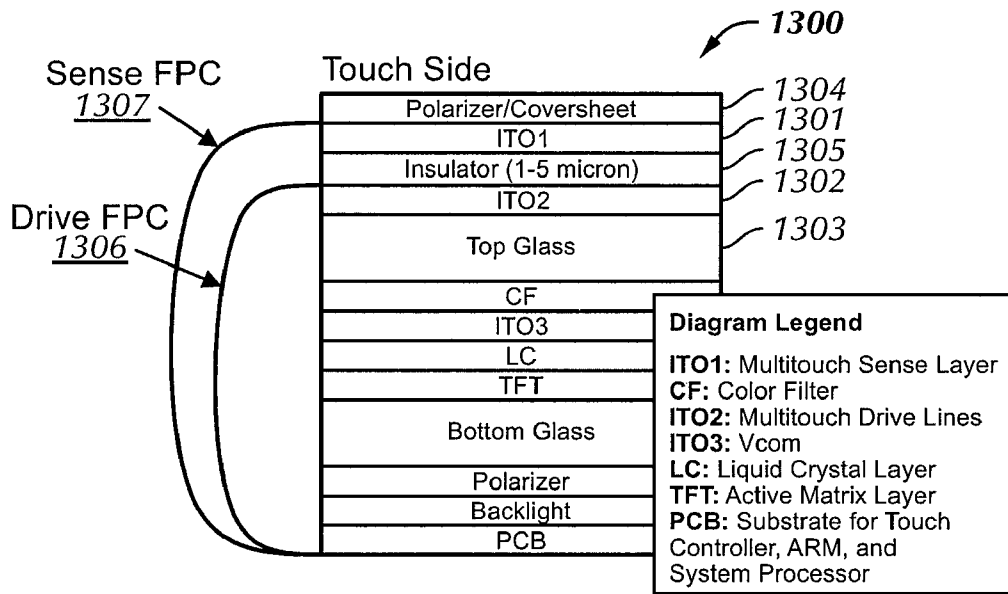

FIG. 13

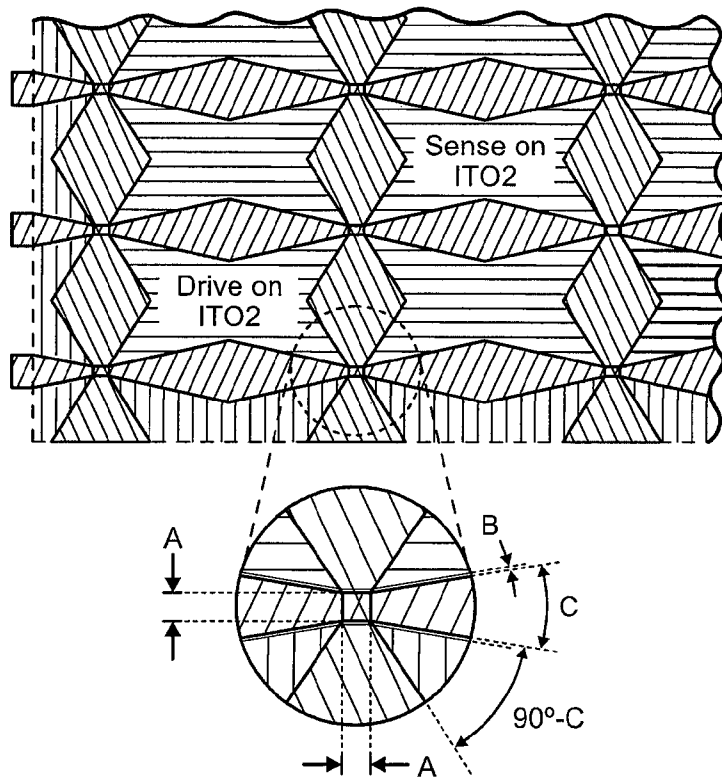

FIG. 14

Touch Side

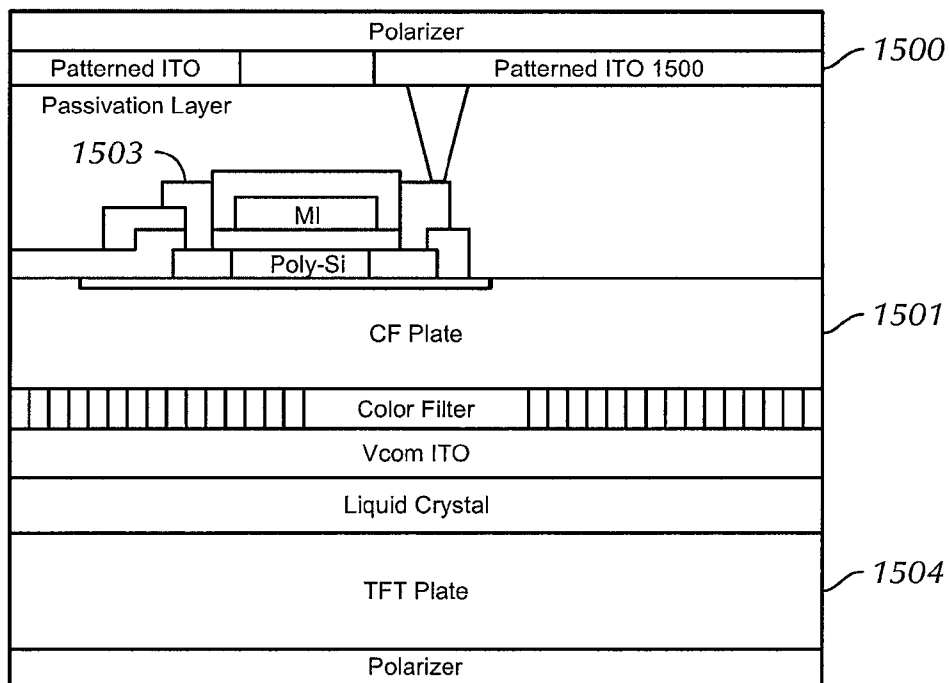

FIG. 15

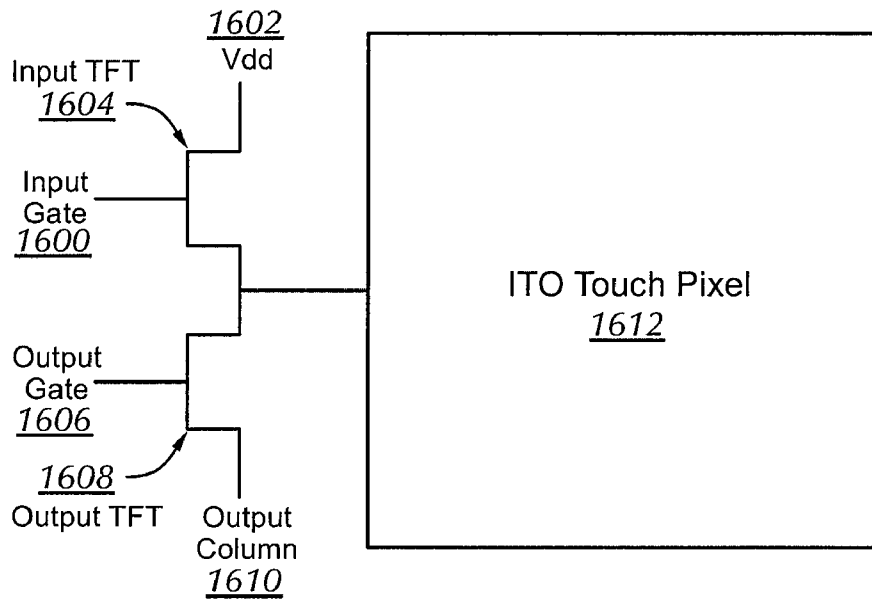

FIG. 16

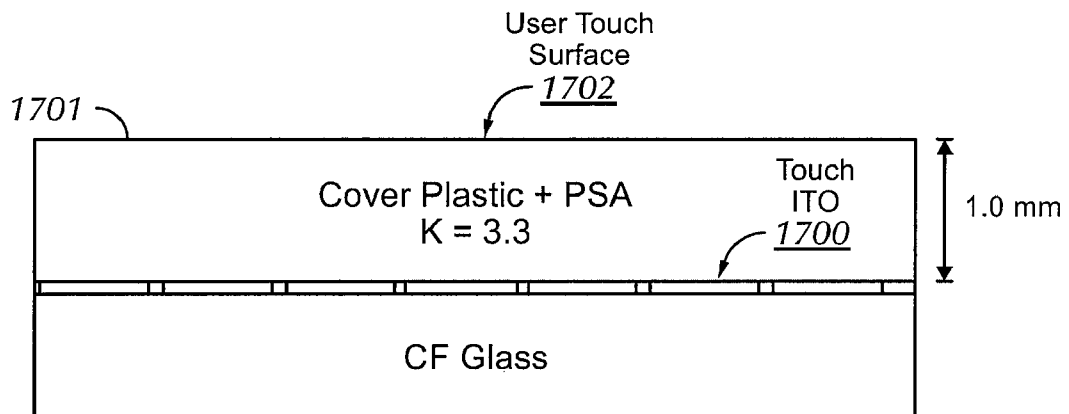

FIG. 17

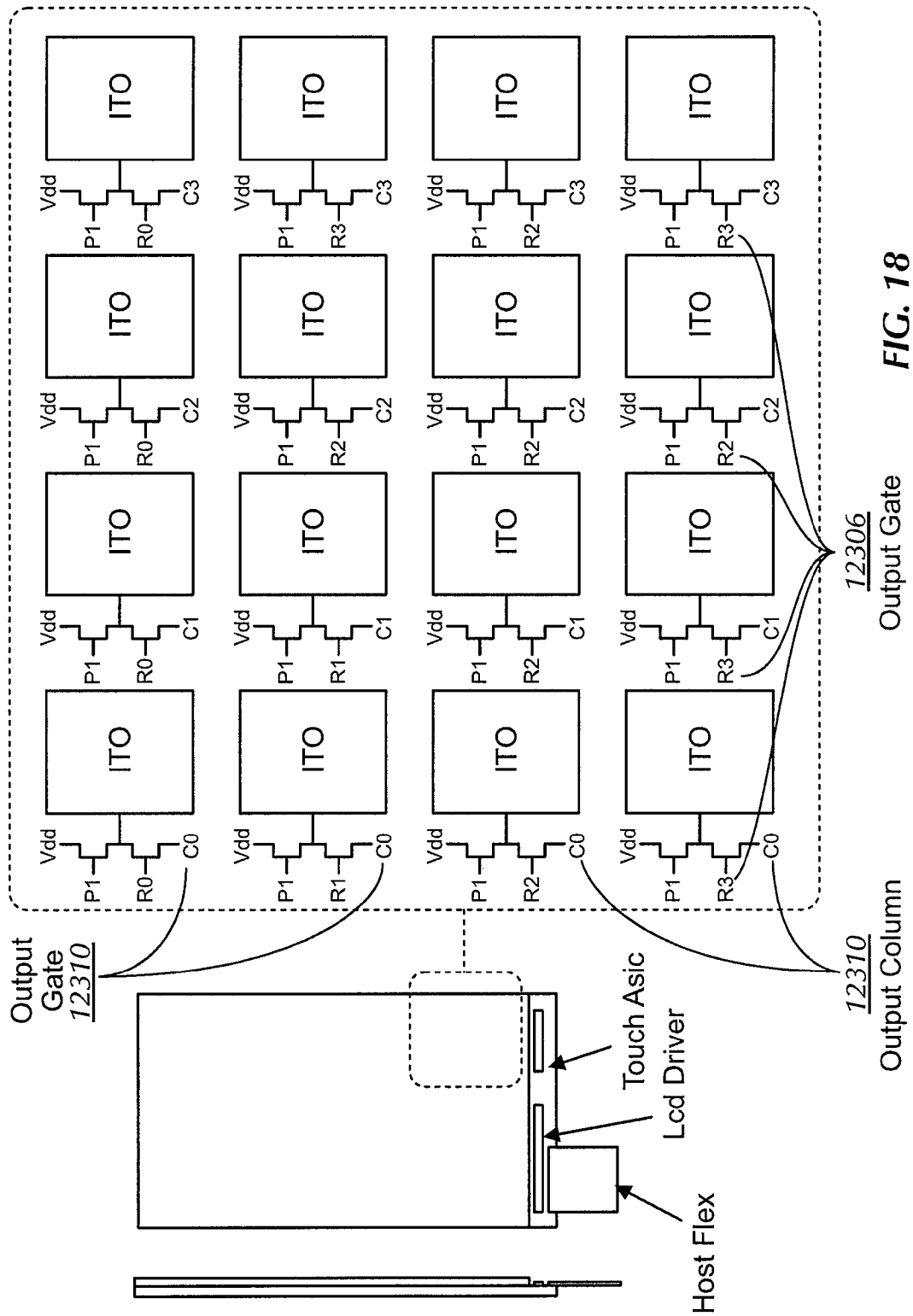

FIG. 18

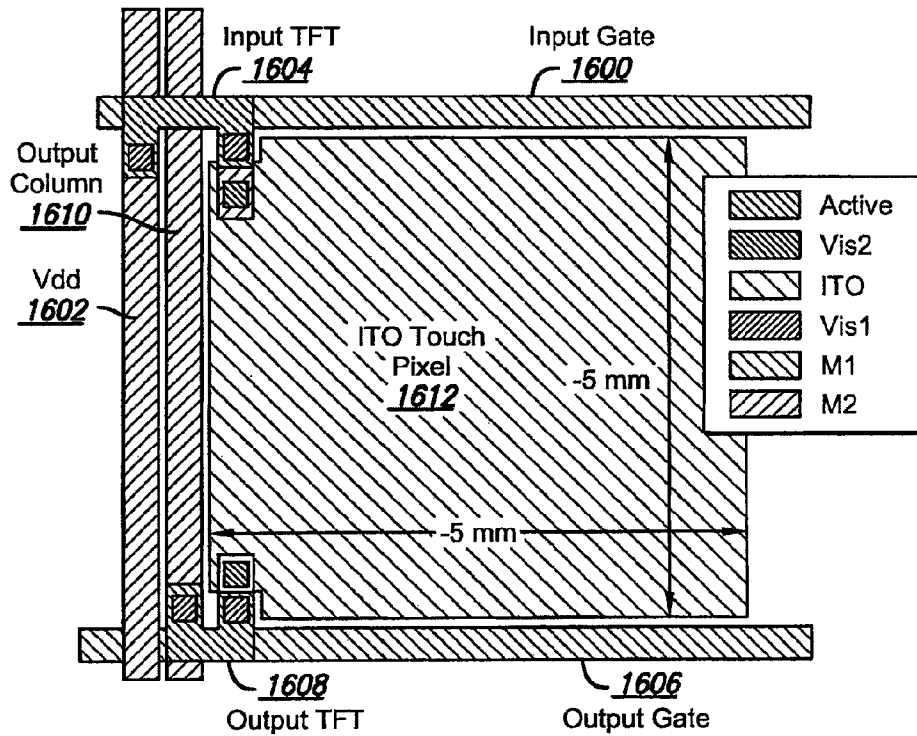

FIG. 19

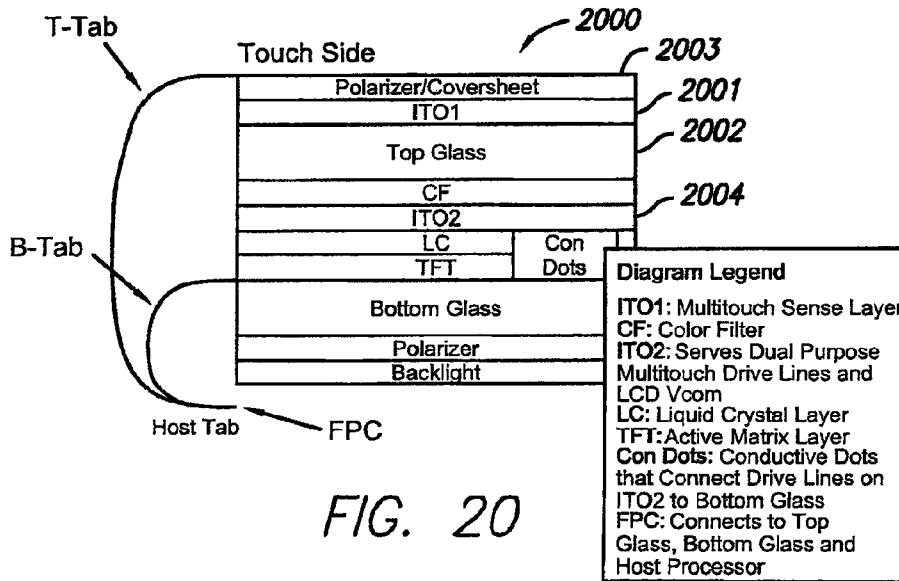

FIG. 20

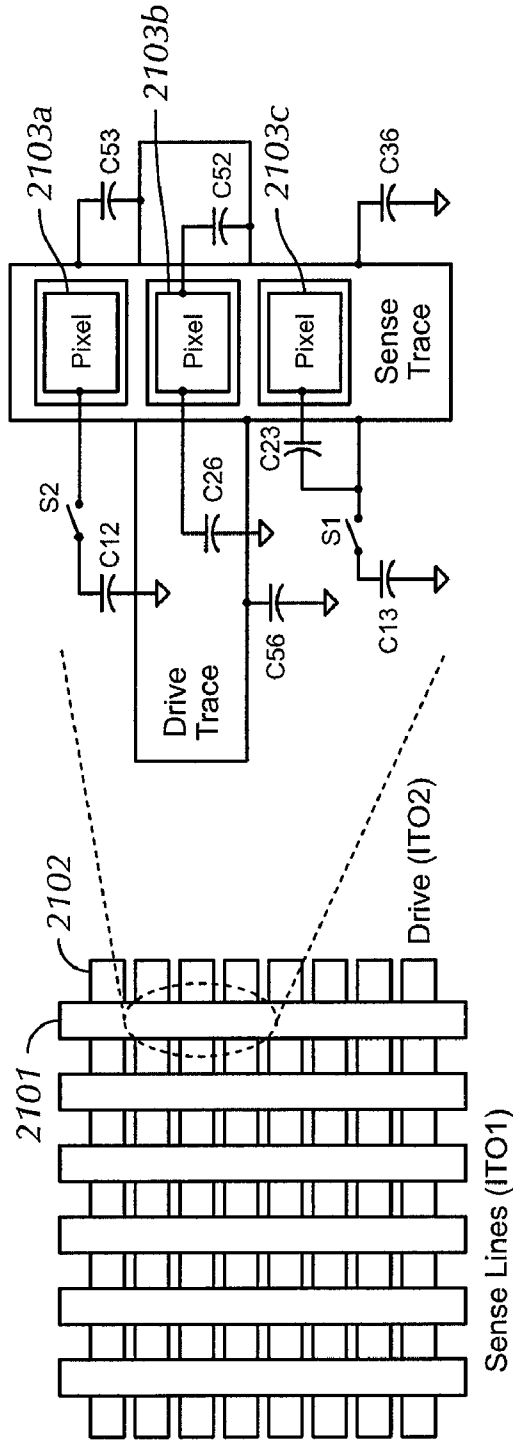

FIG. 21

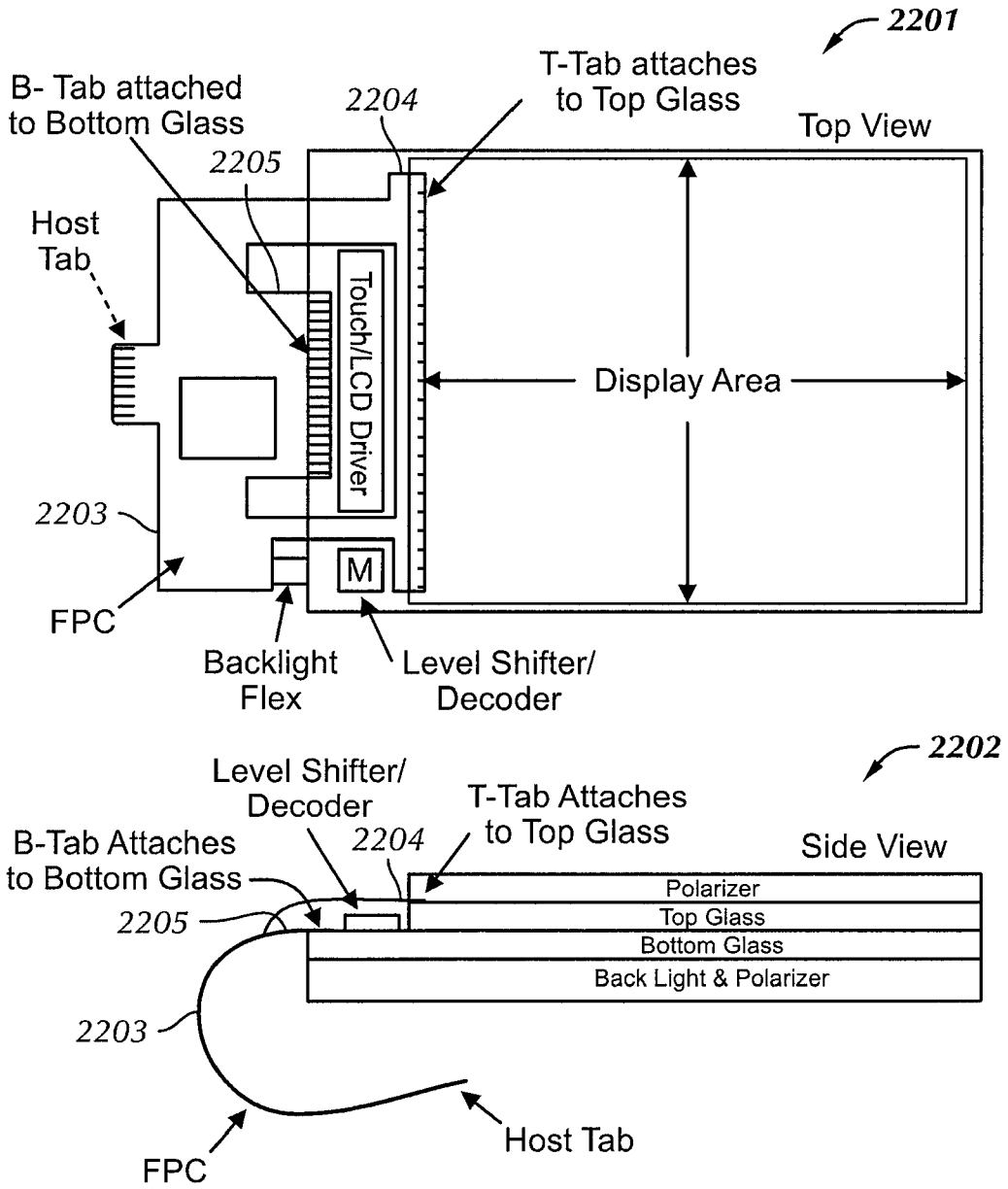

FIG. 22

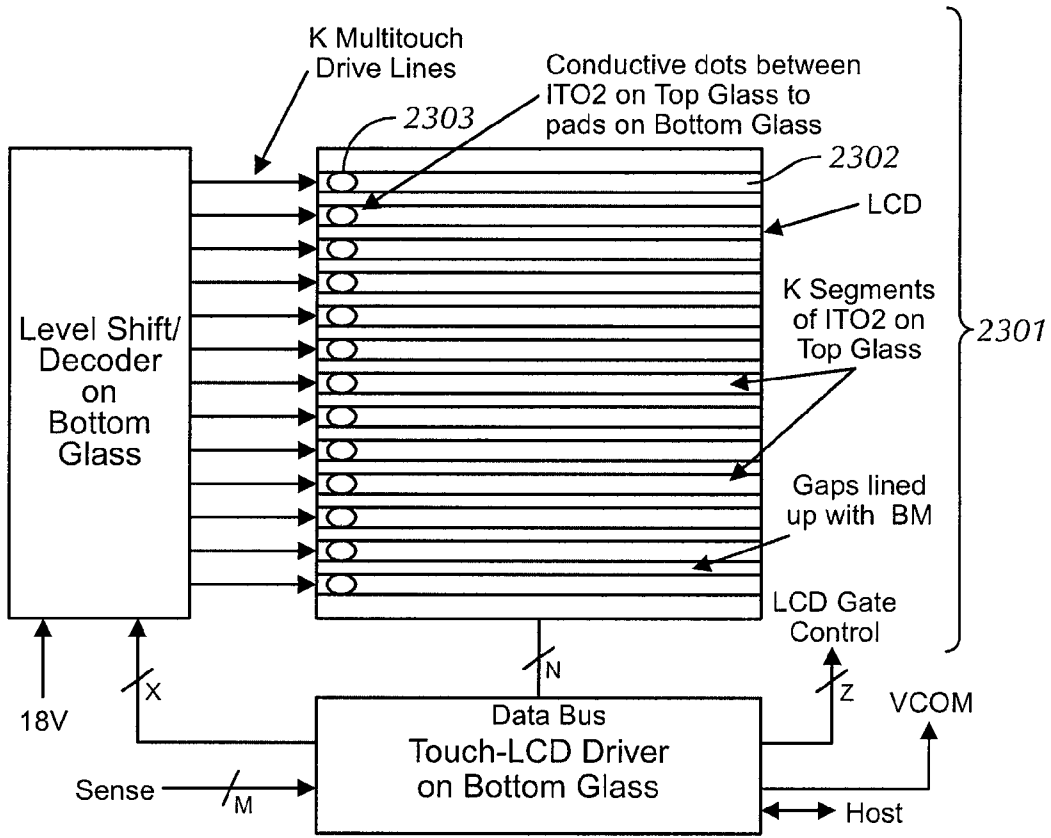

FIG. 23

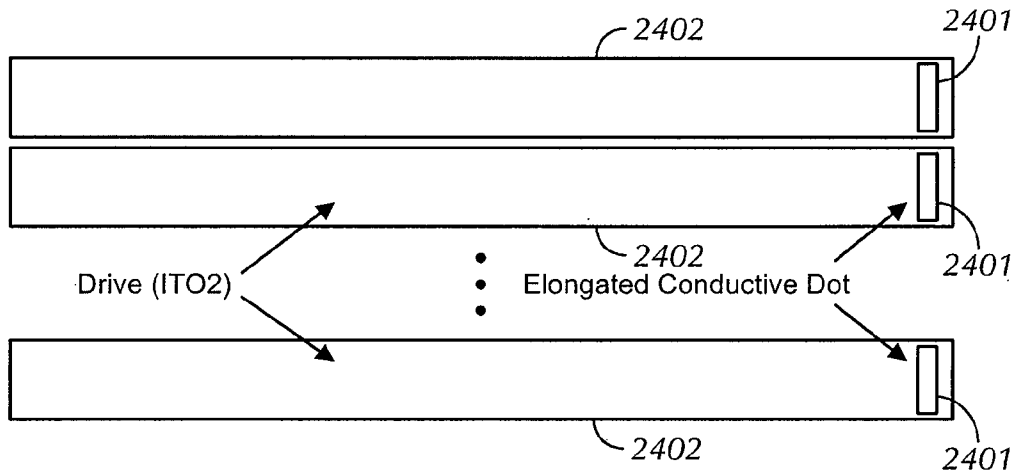

FIG. 24

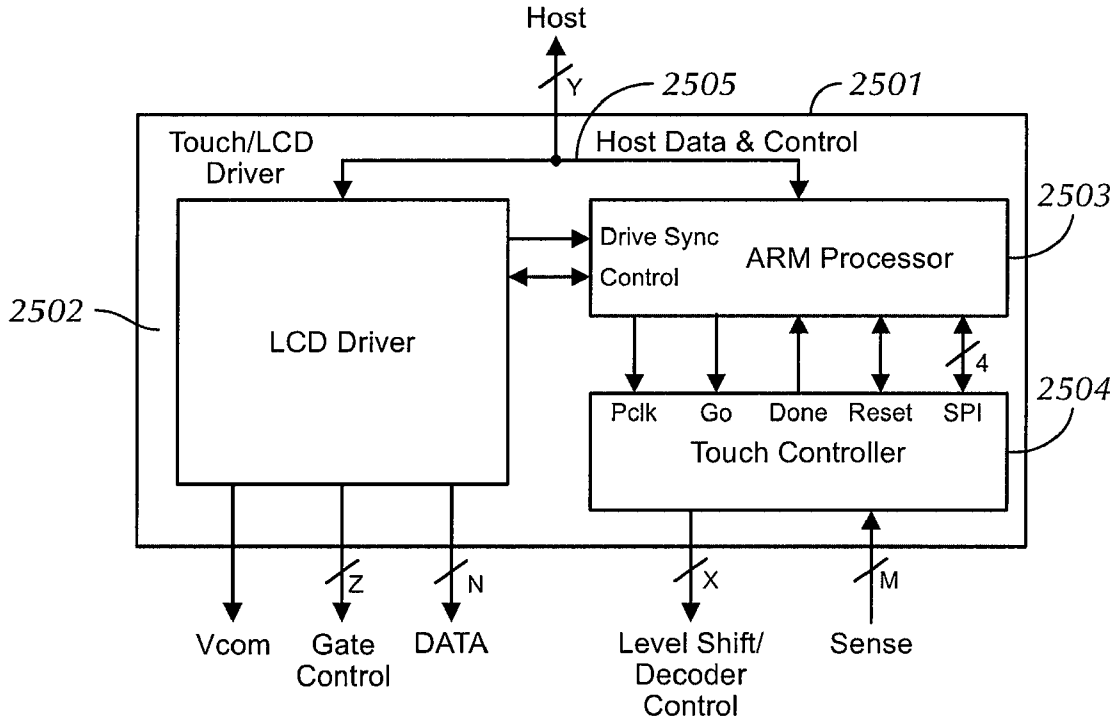

FIG. 25

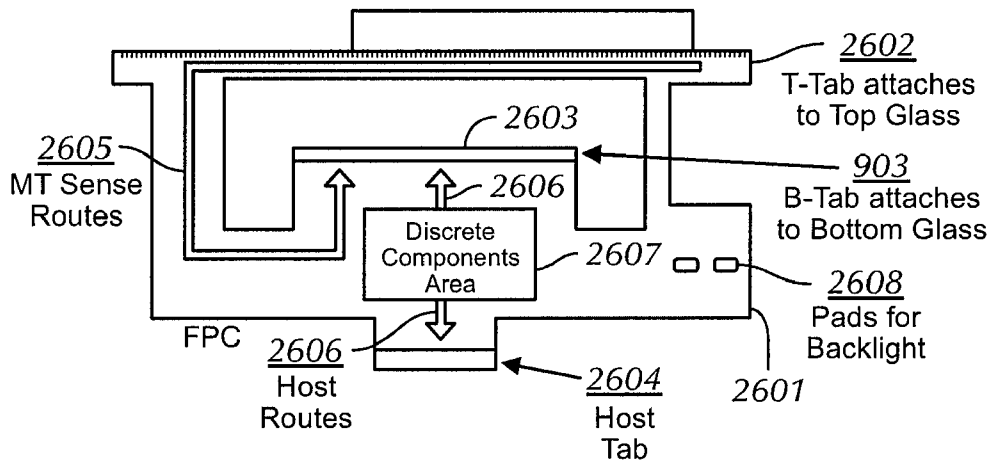

FIG. 26

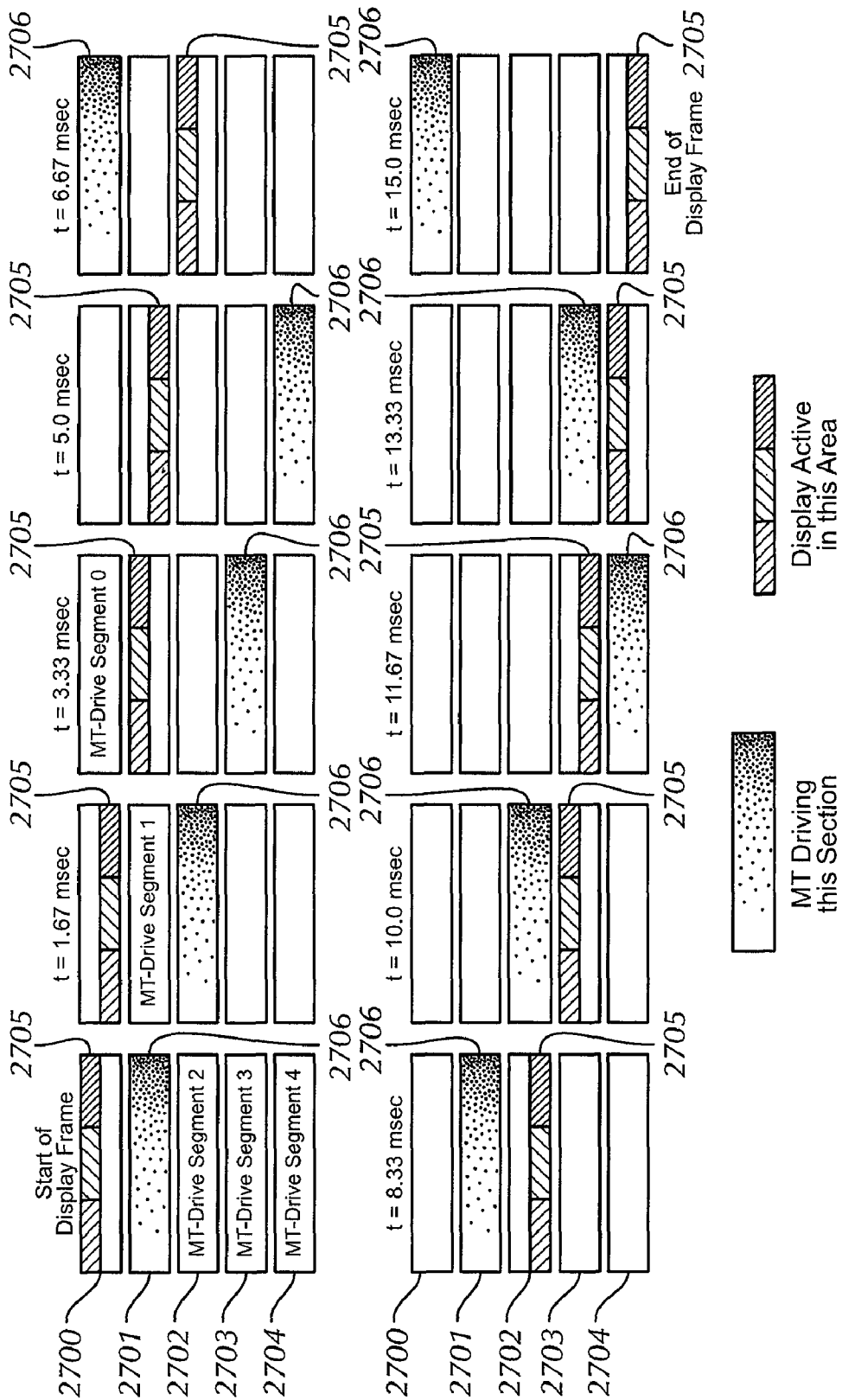

FIG. 27

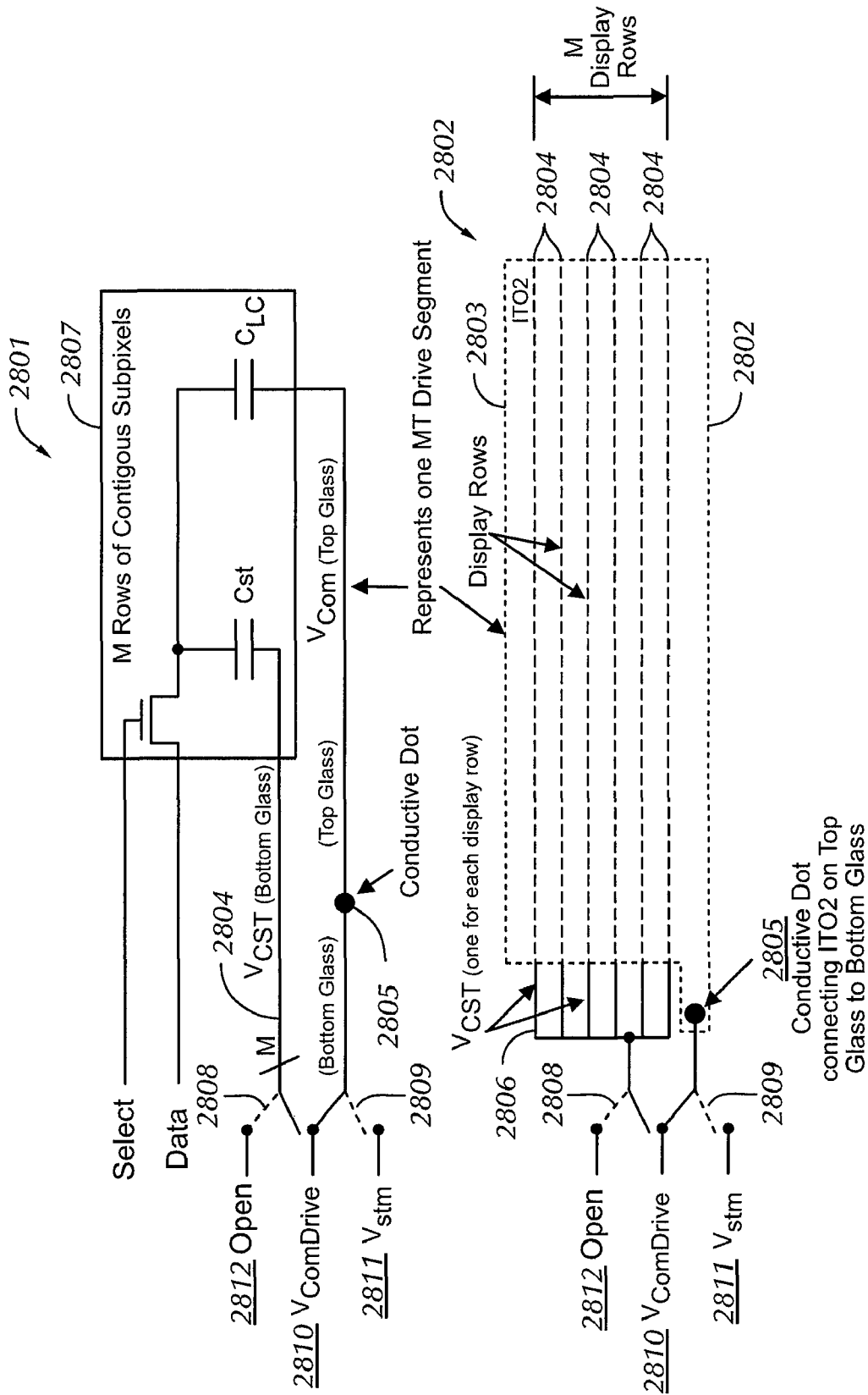

FIG. 28

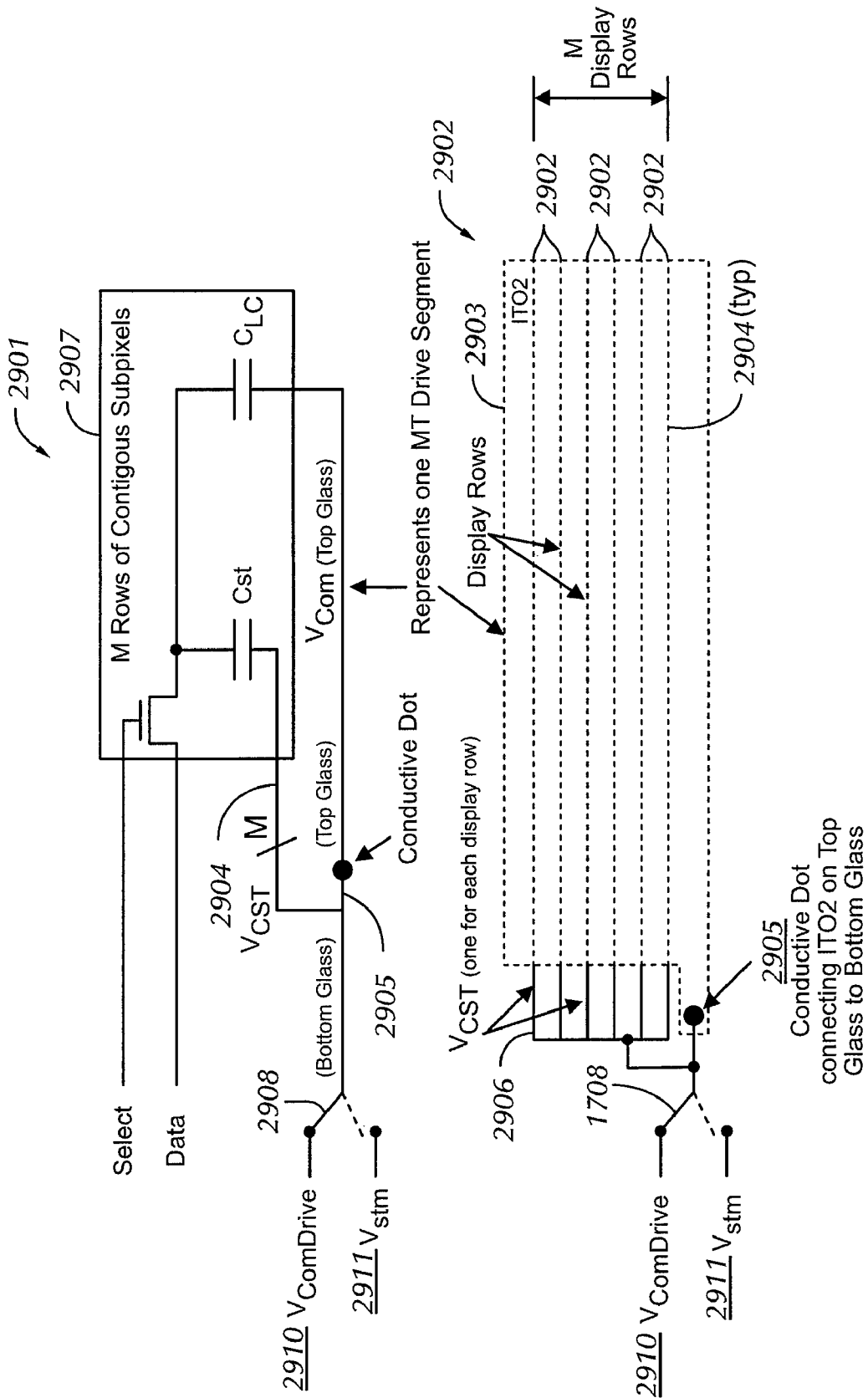
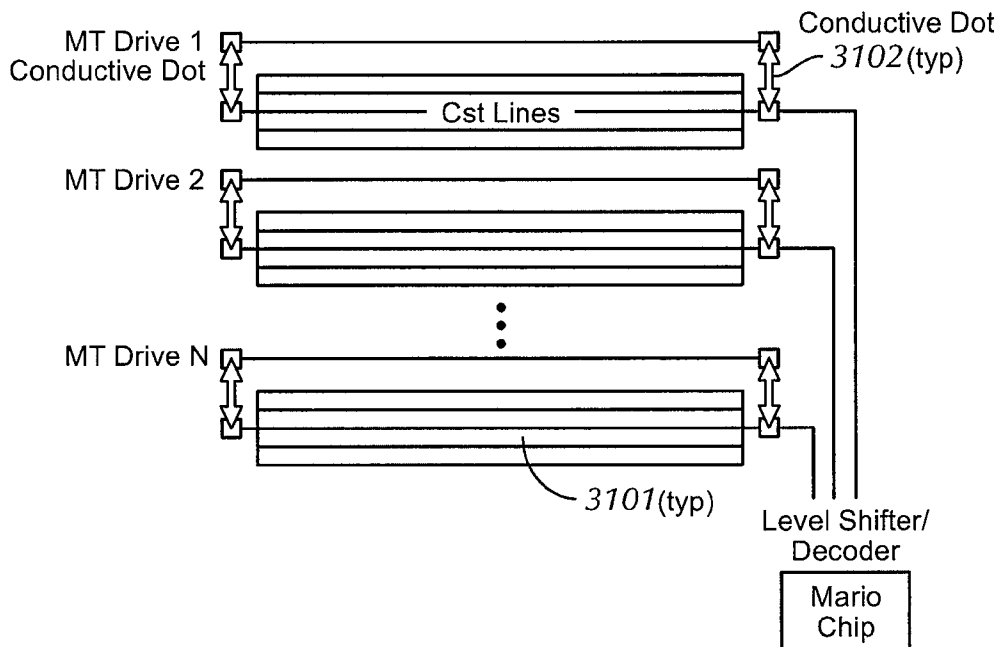
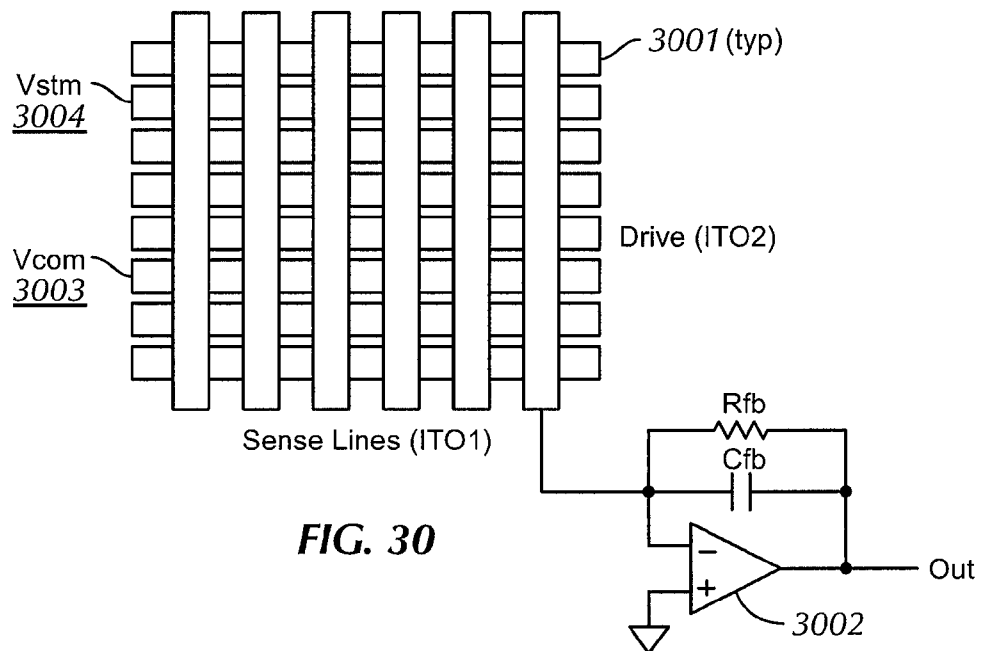

FIG. 29



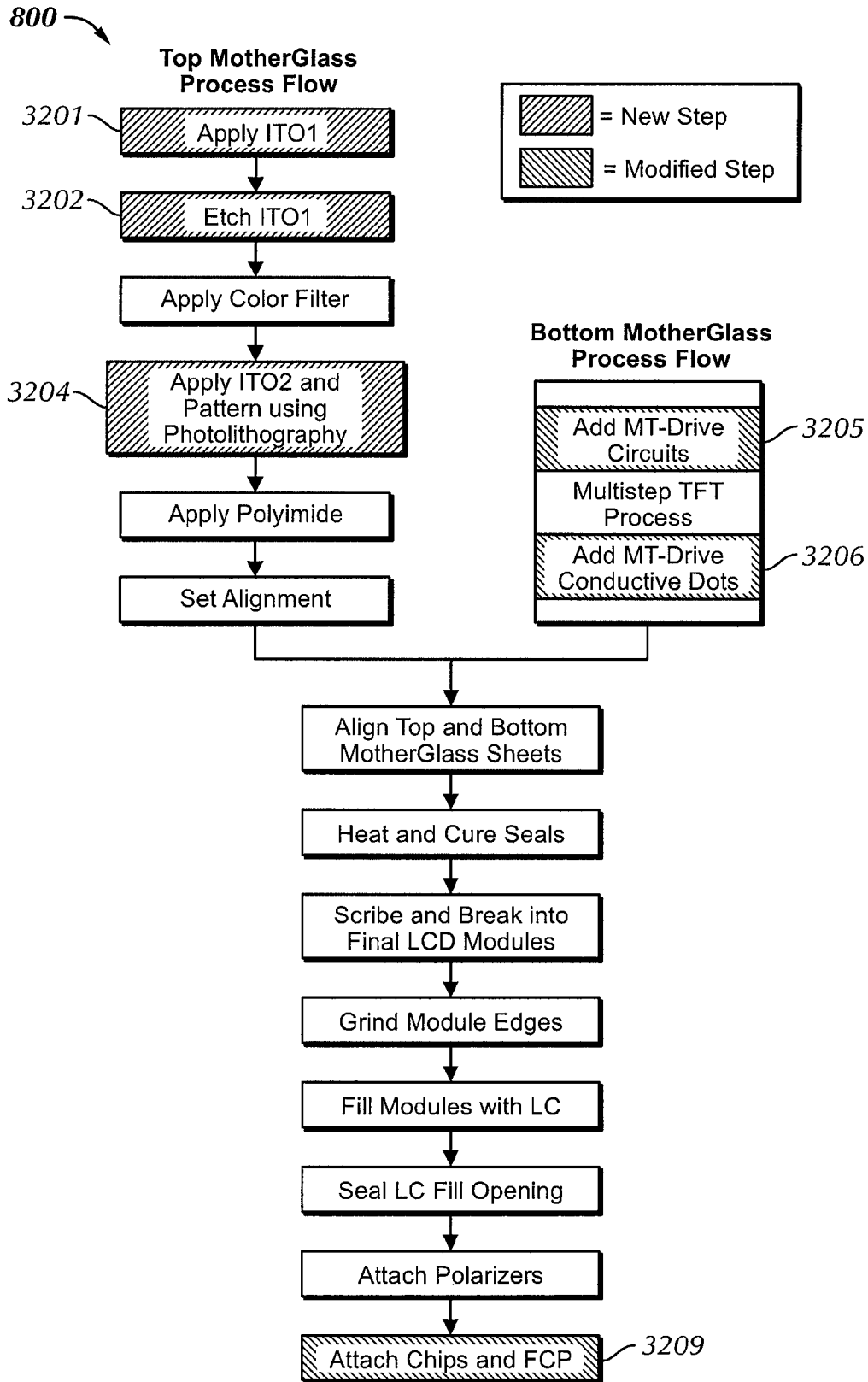

FIG. 32

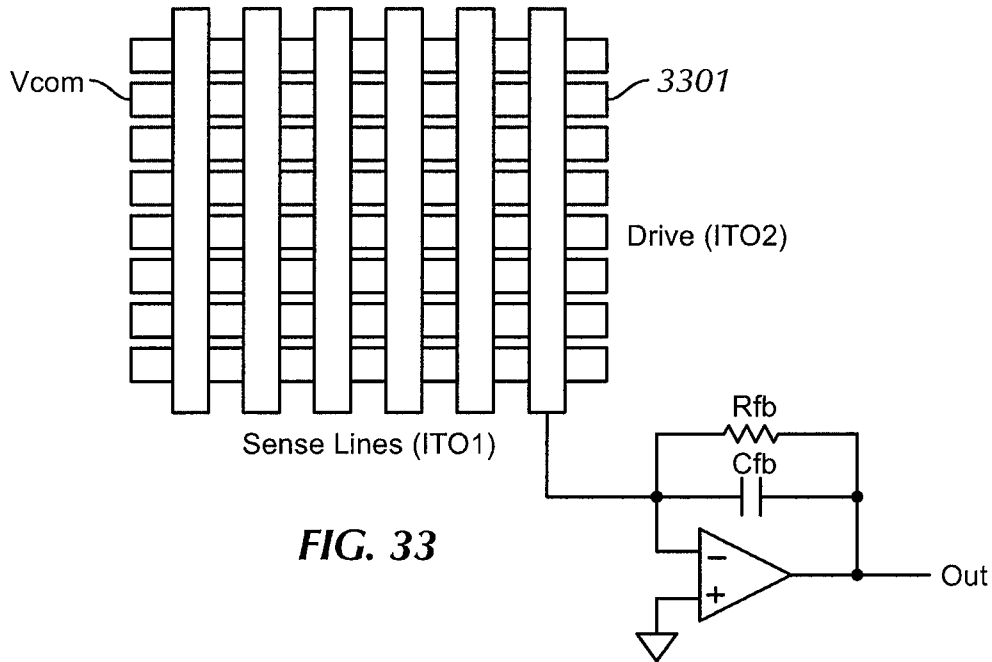

FIG. 33

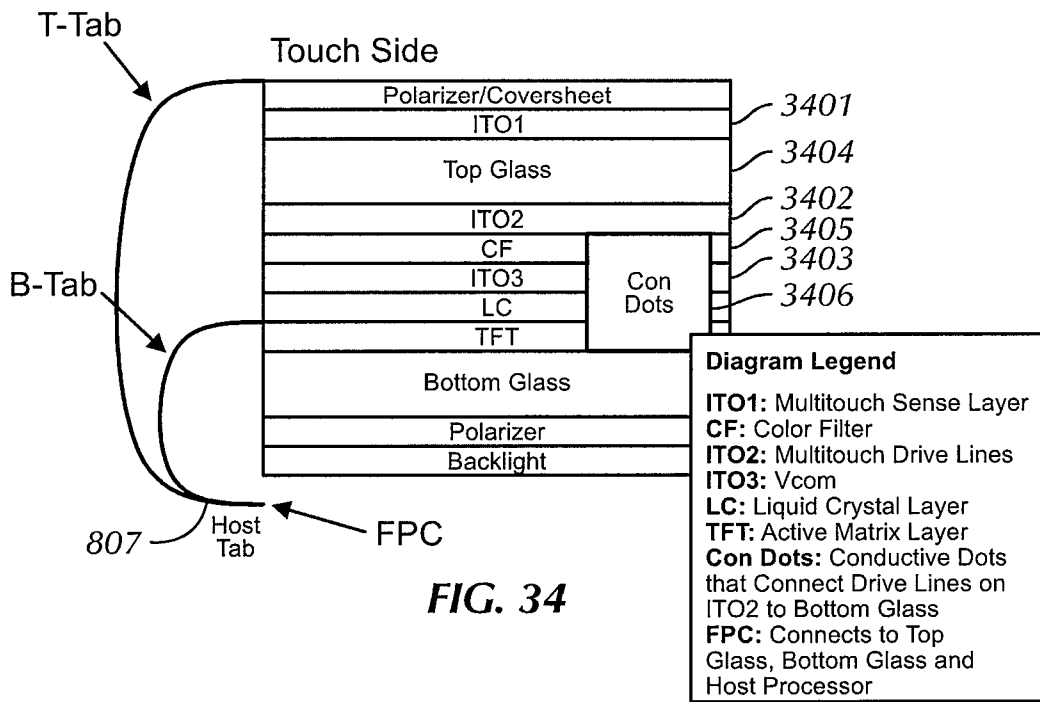

FIG. 34

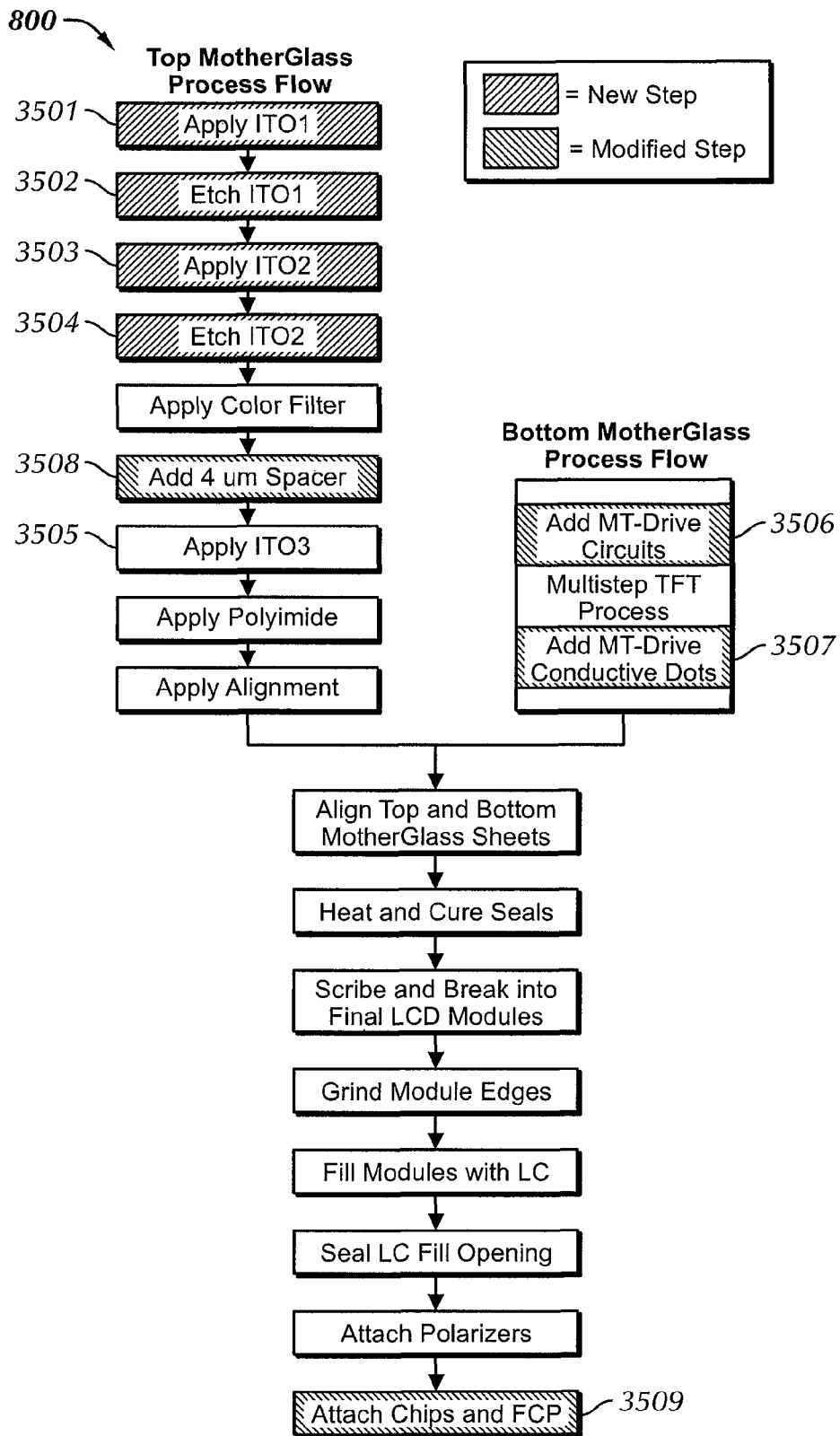

FIG. 35

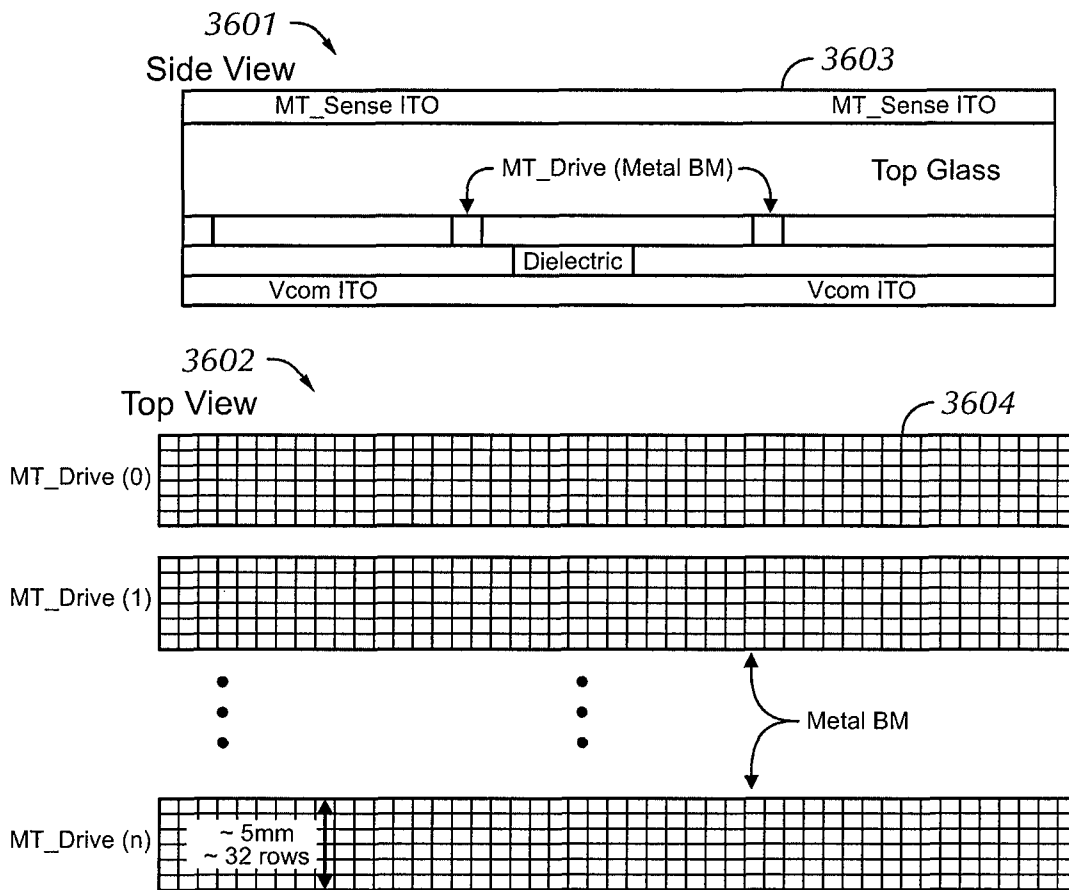

FIG. 36

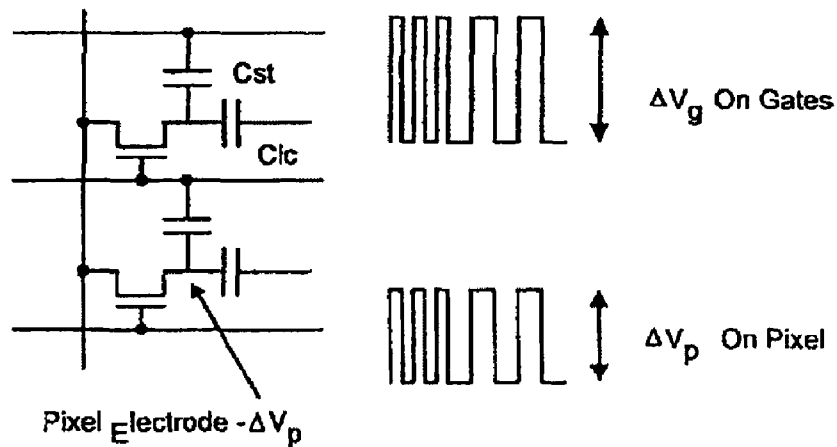

FIG. 37

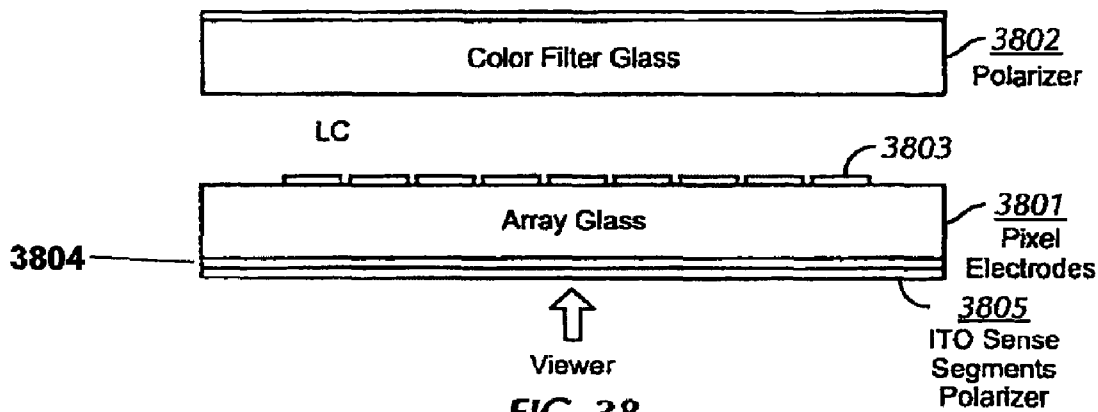

FIG. 38

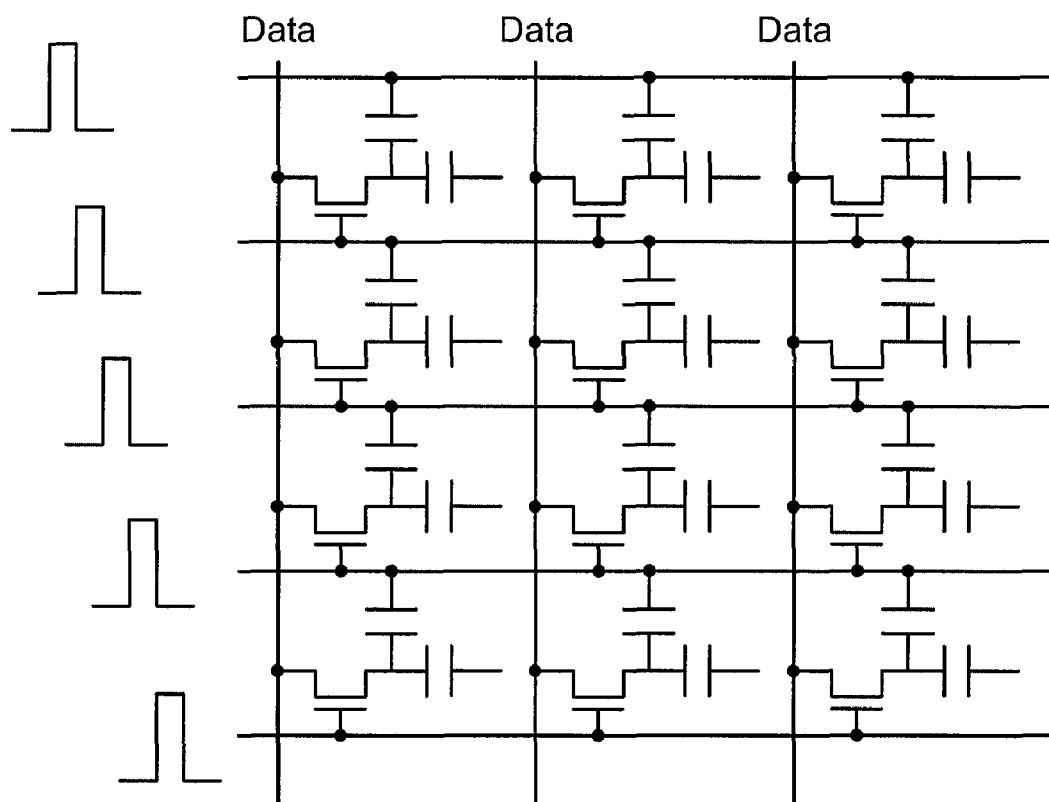

FIG. 39

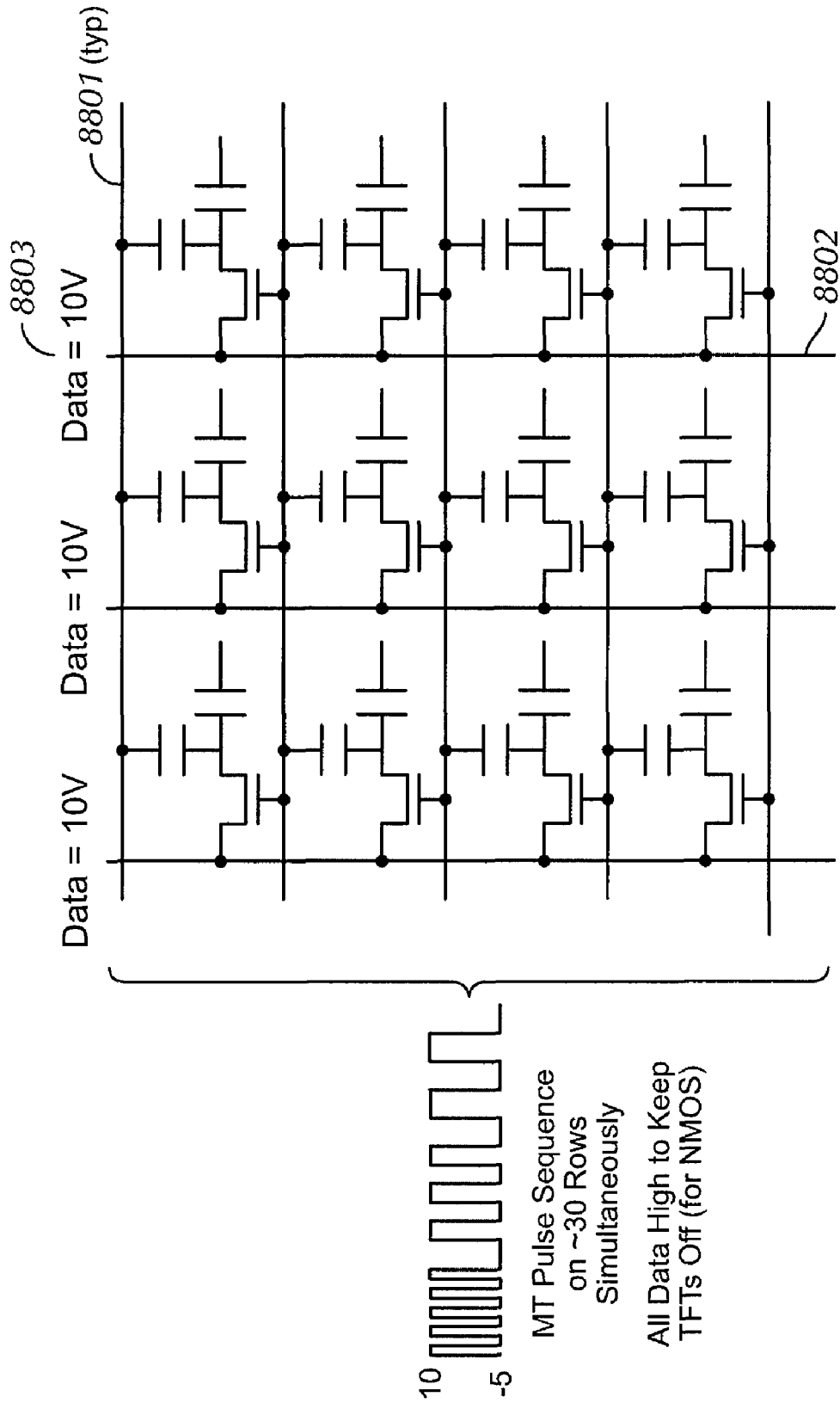

FIG. 40

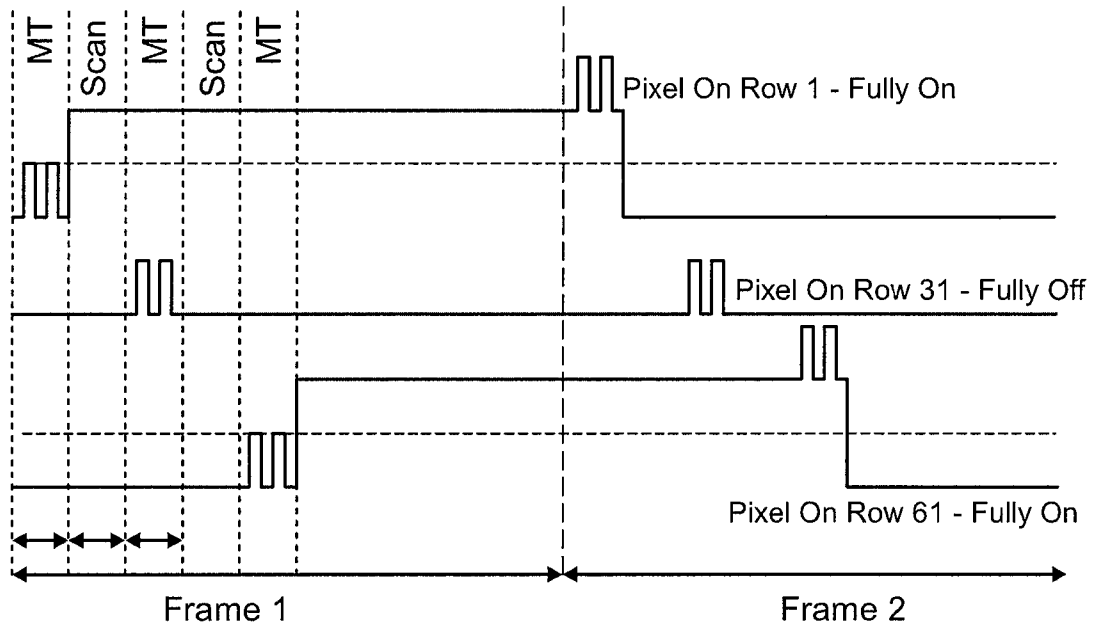

FIG. 41

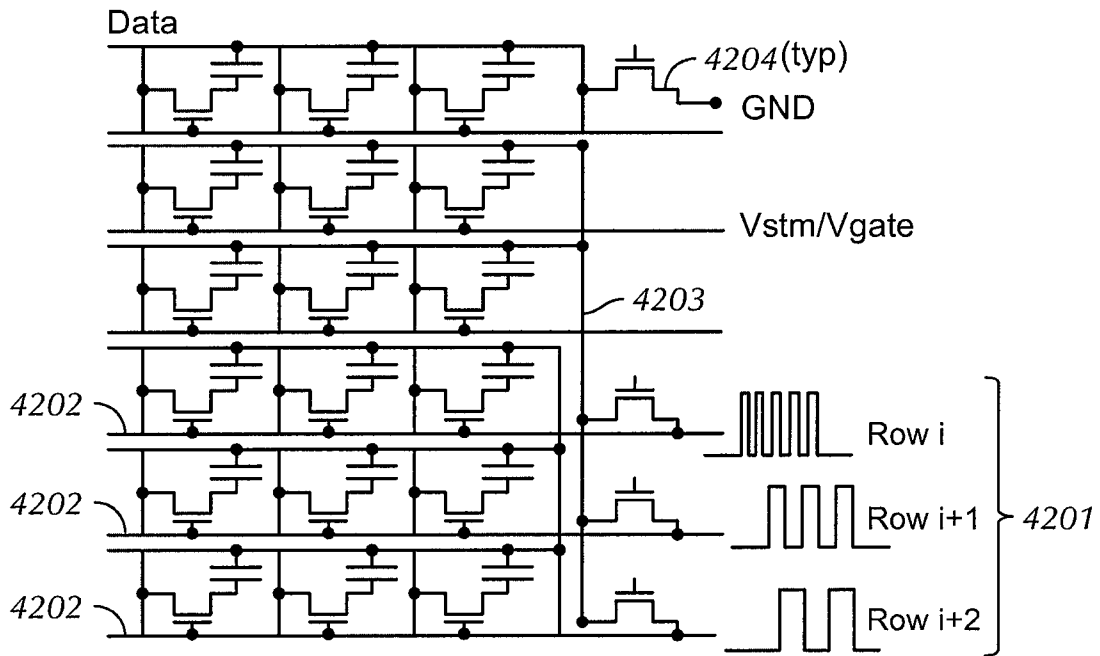

FIG. 42

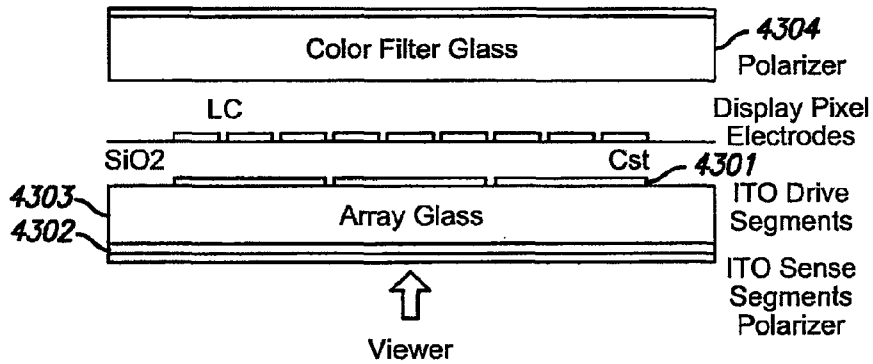

FIG. 43

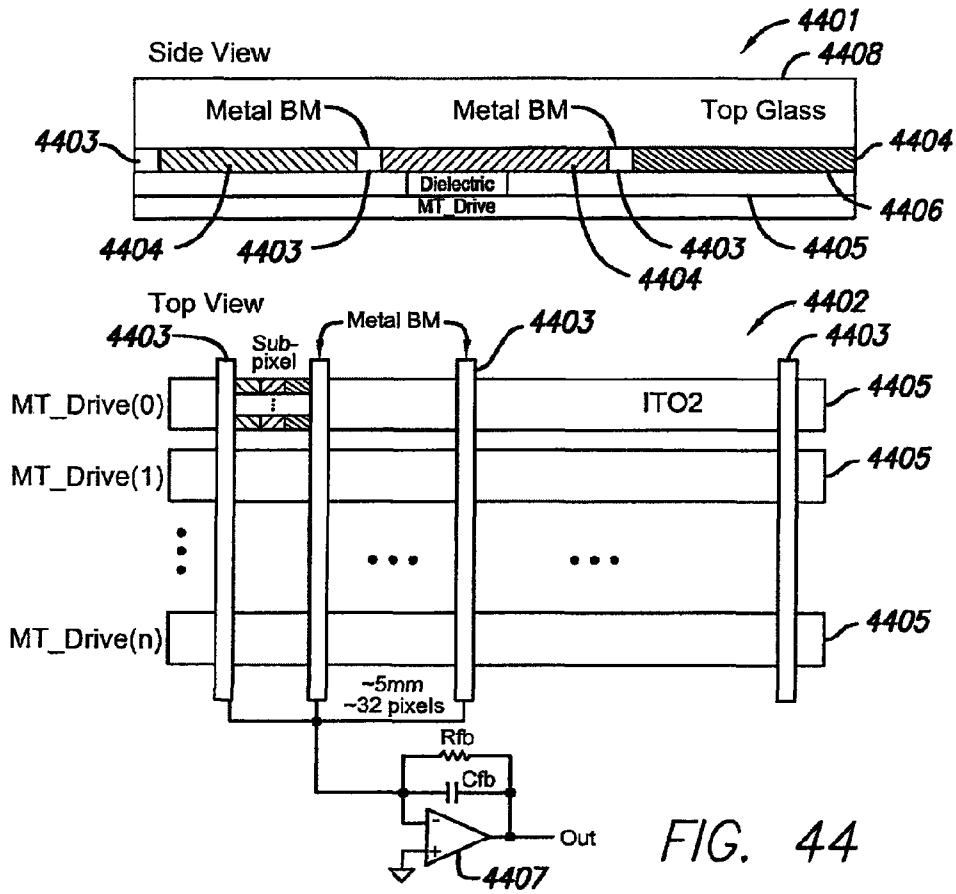

FIG. 44

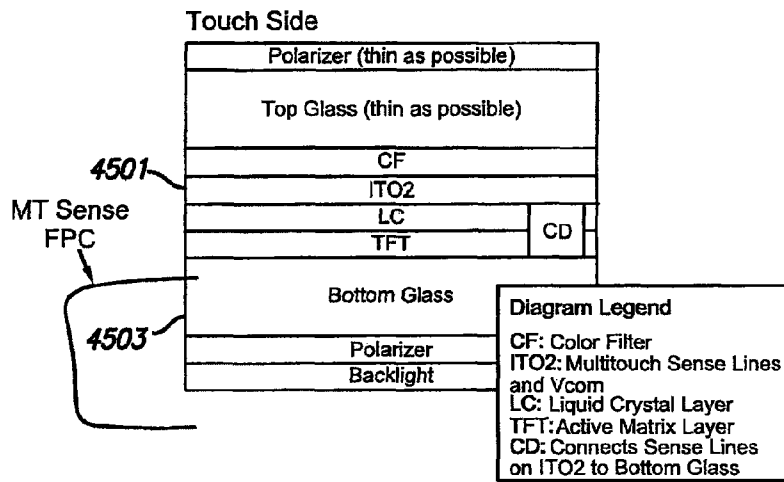

FIG. 45

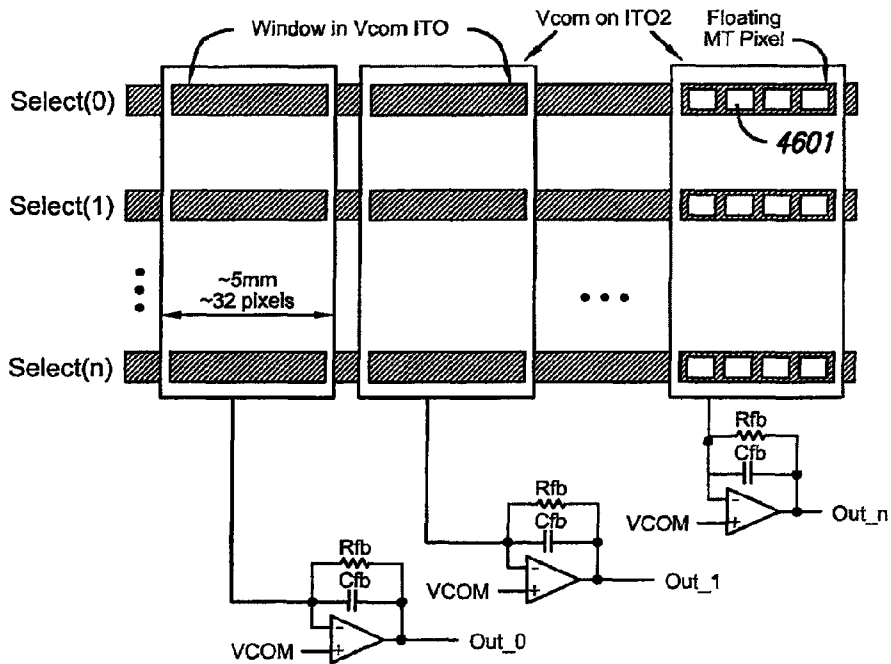

FIG. 46

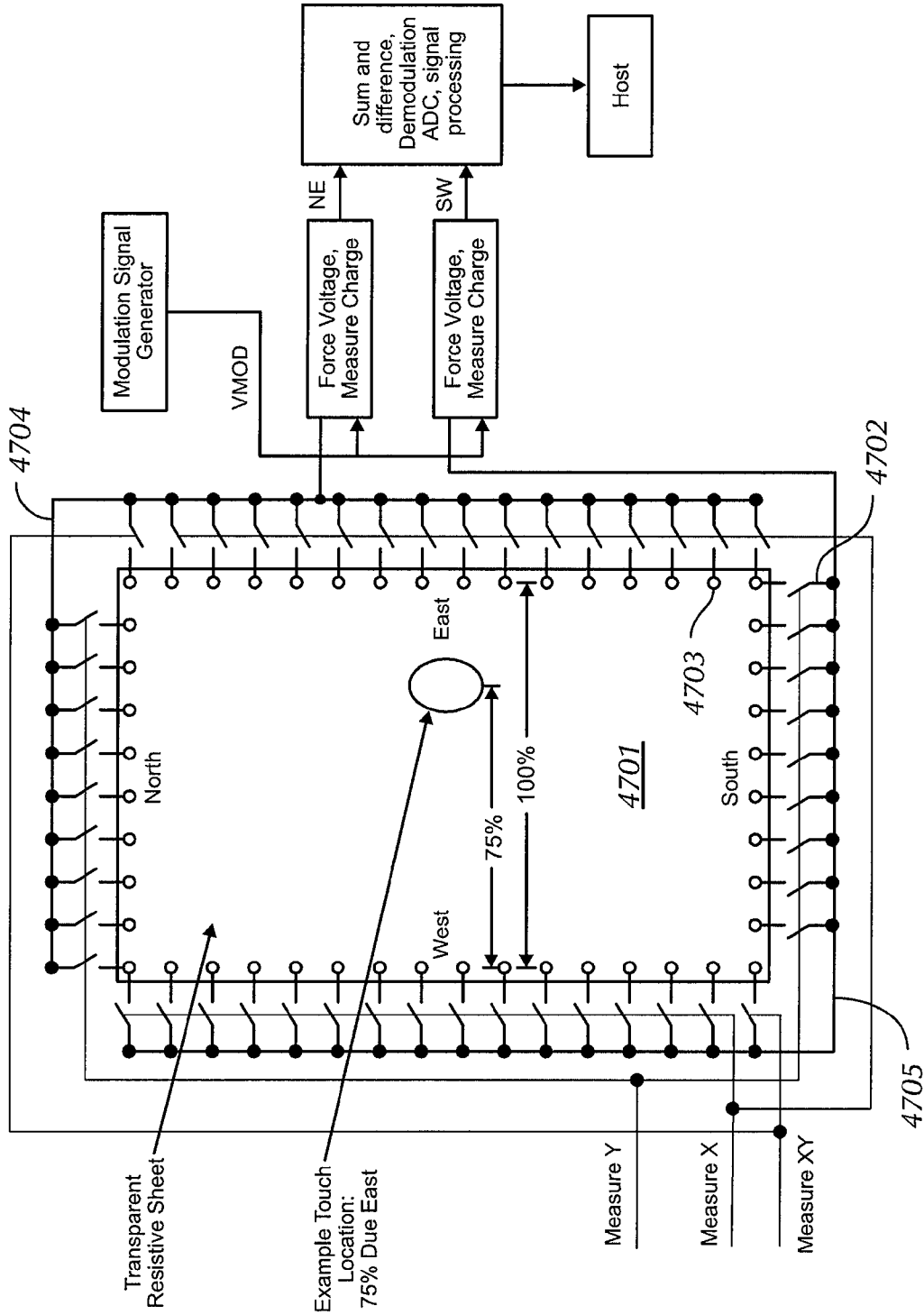

FIG. 47

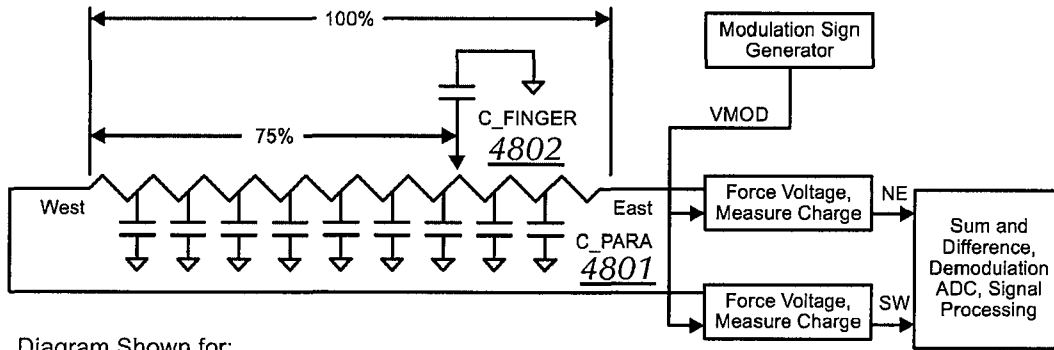
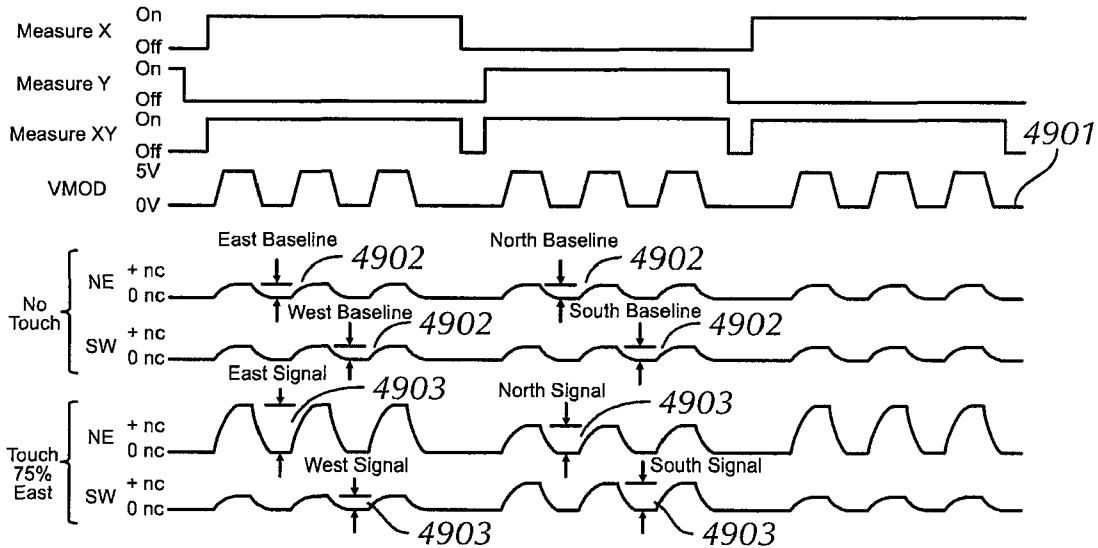

Diagram Shown for:
 "Measure X" On
 "Measure XY" On
 "Measure Y" Off

C_PARA is parasitic capacitance distributed across touch panel.
 C_FINGER is signal capacitance associated with a touch on the touch panel.

FIG. 48



$$Zew = (East\ Signal - East\ Baseline) + (West\ Signal - West\ Baseline)$$

$$Zns = (North\ Signal - North\ Baseline) + (South\ Signal - South\ Baseline)$$

$$X = (East\ Signal - East\ Baseline) / Zew$$

$$Y = (North\ Signal - North\ Baseline) / Zns$$

FIG. 49

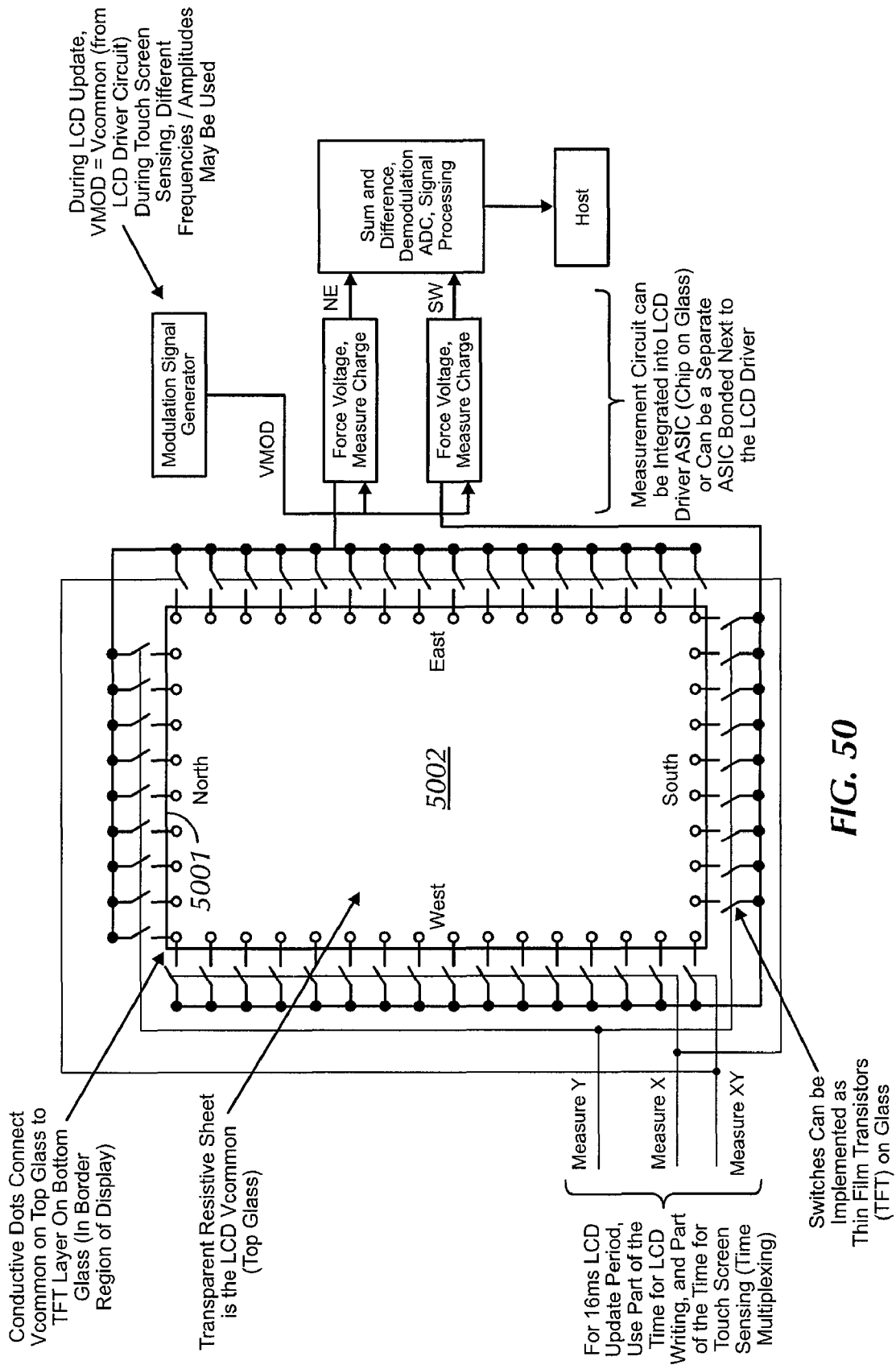

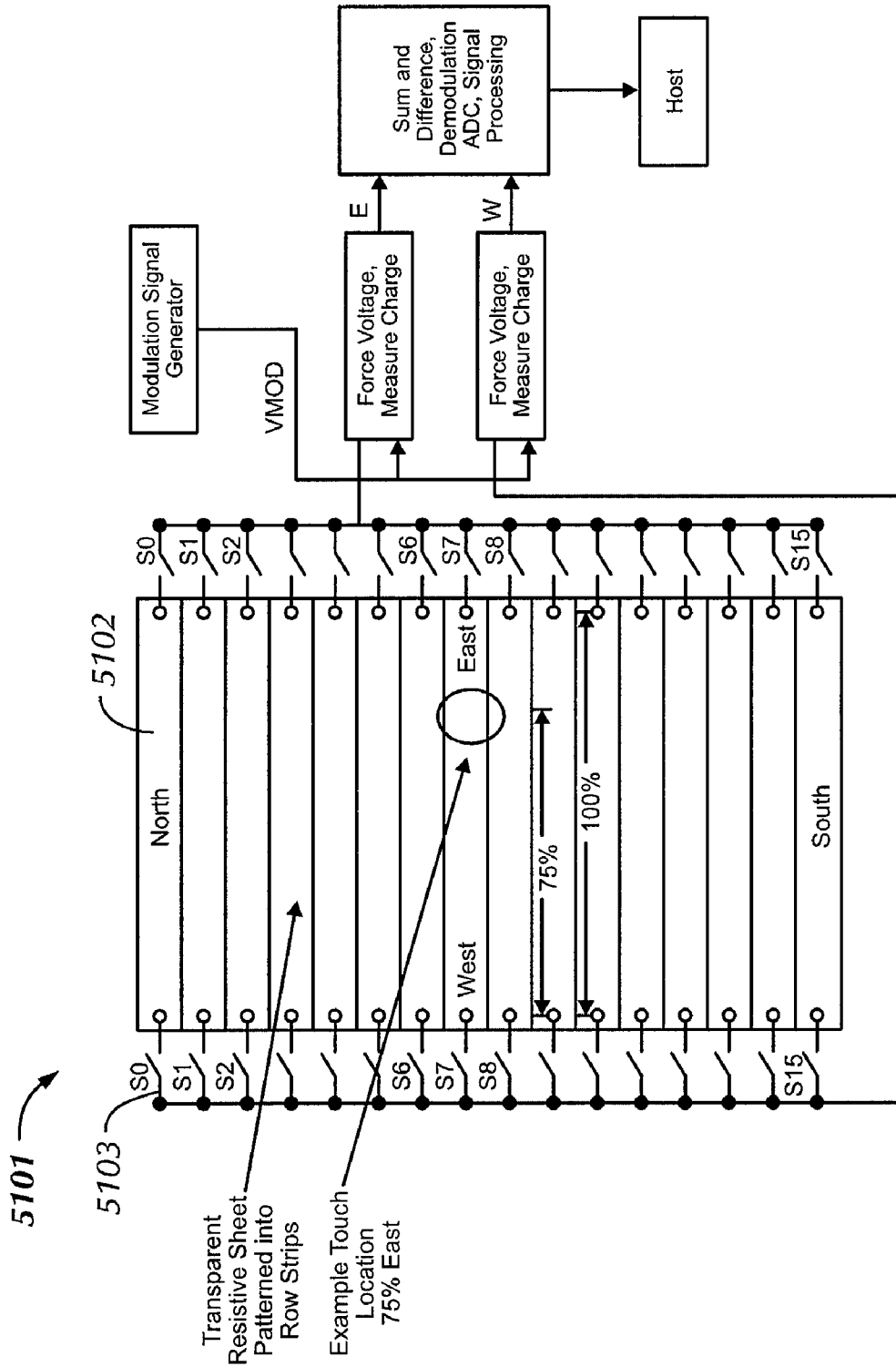
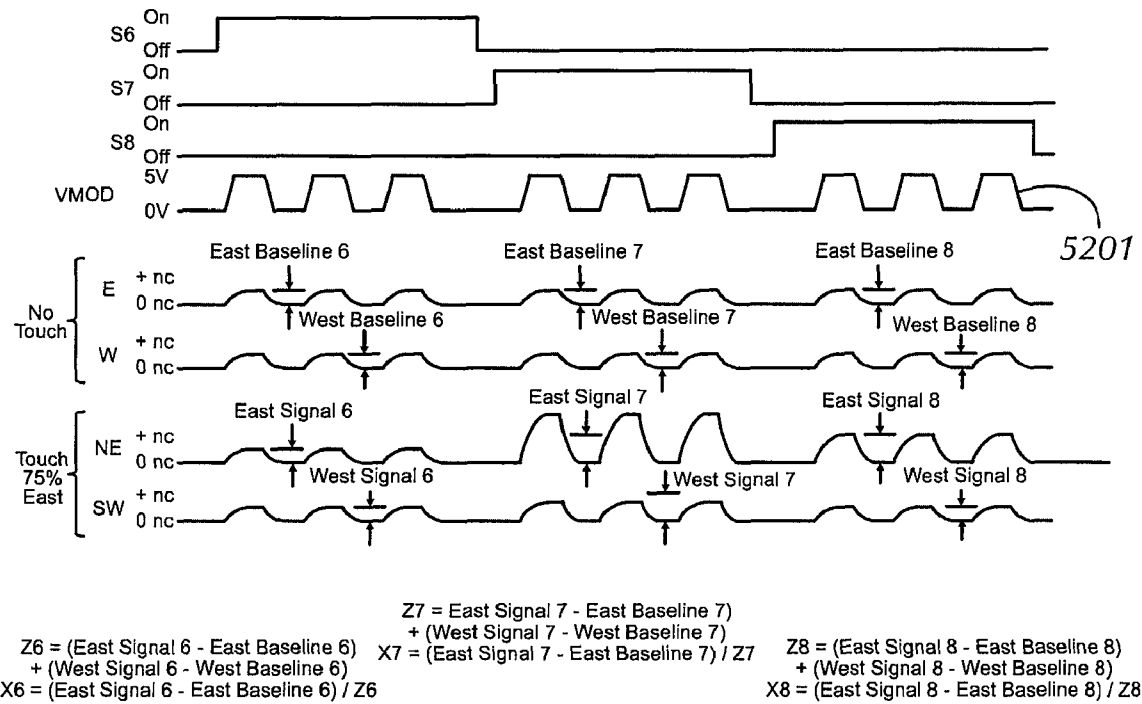
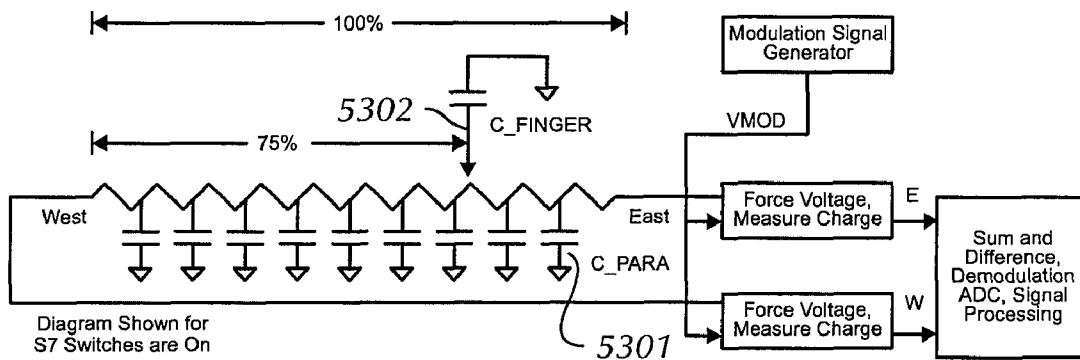

FIG. 51



Y output(s) are determined by centroids of Z outputs for each row.
 X output(s) are determined by weighted average of X outputs for each row.

FIG. 52



C_PARA is parasitic capacitance distributed across raw strip.
 C_FINGER is signal capacitance associated with a touch on the touch panel.

FIG. 53

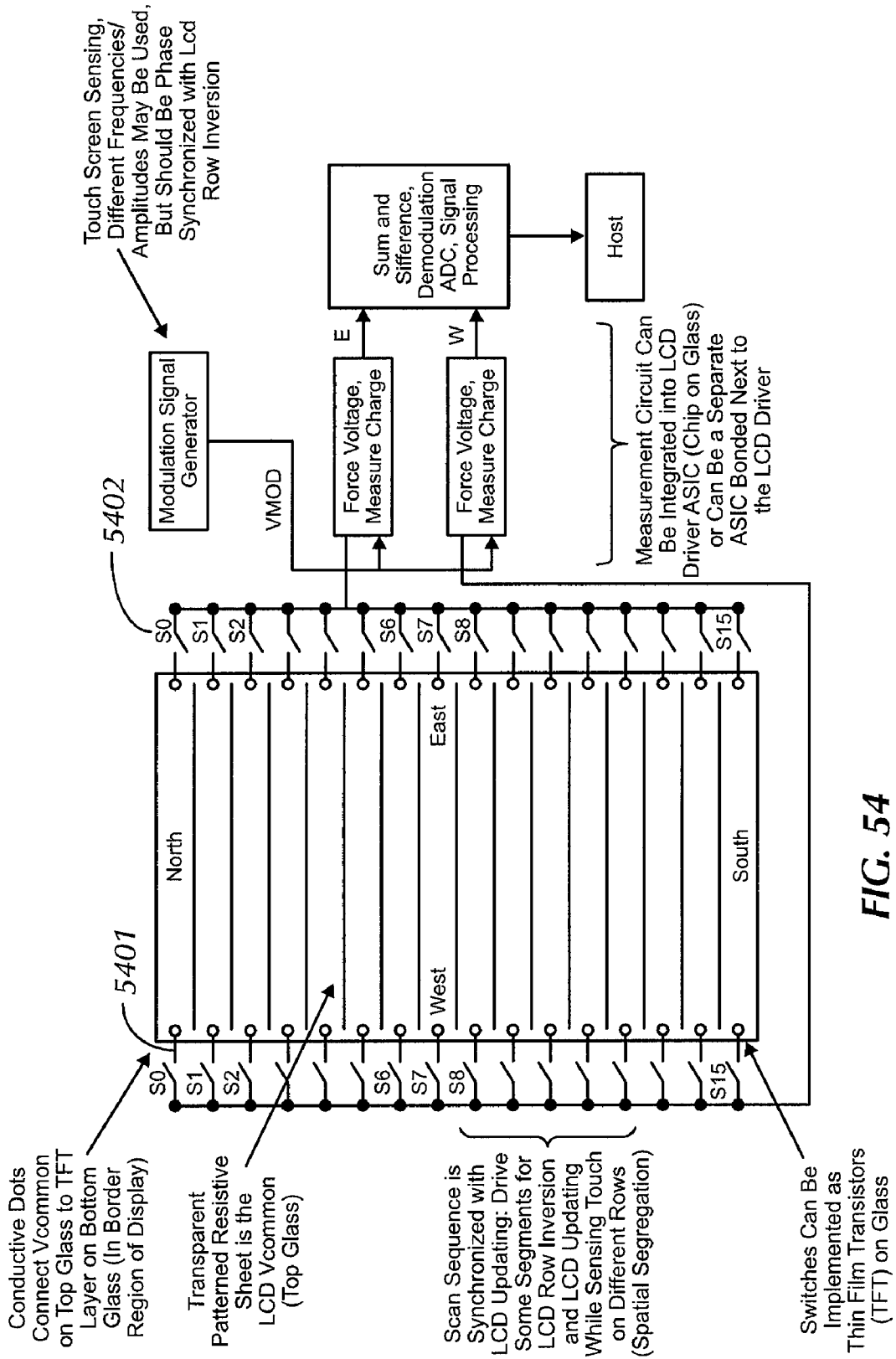

FIG. 54

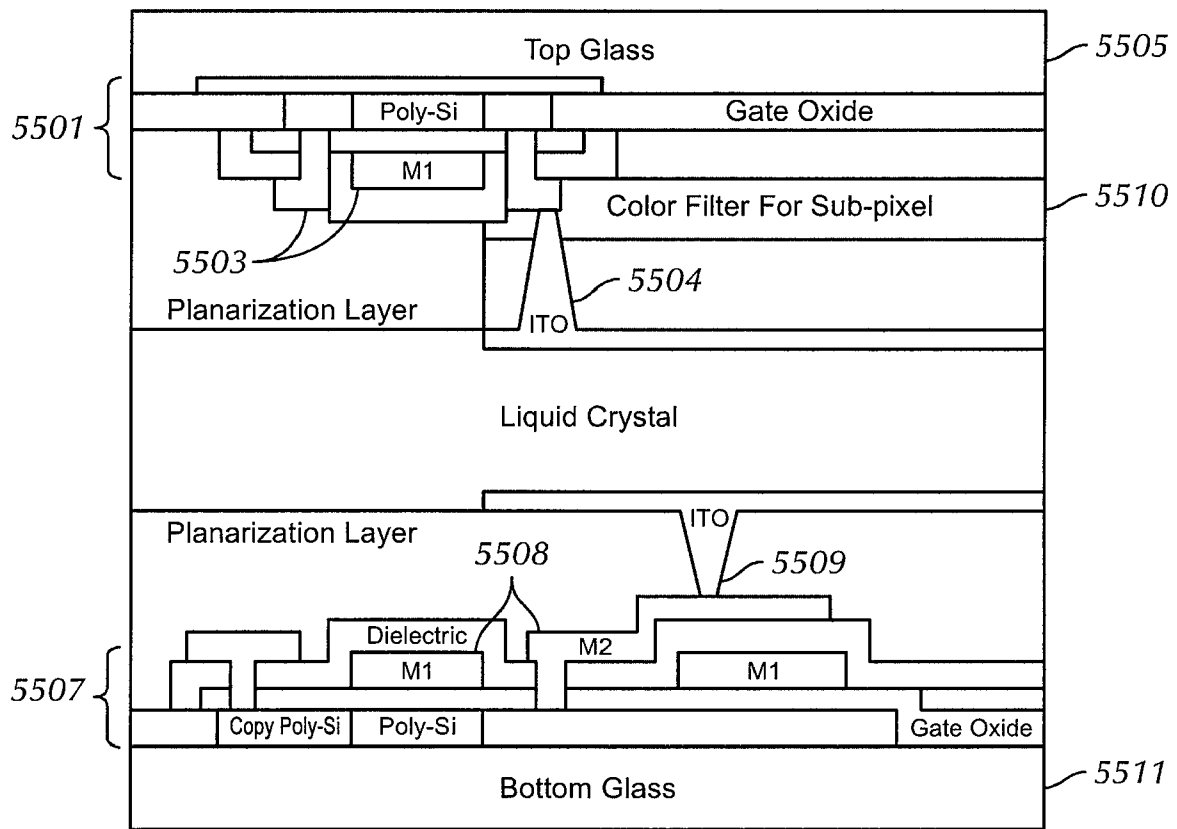

FIG. 55

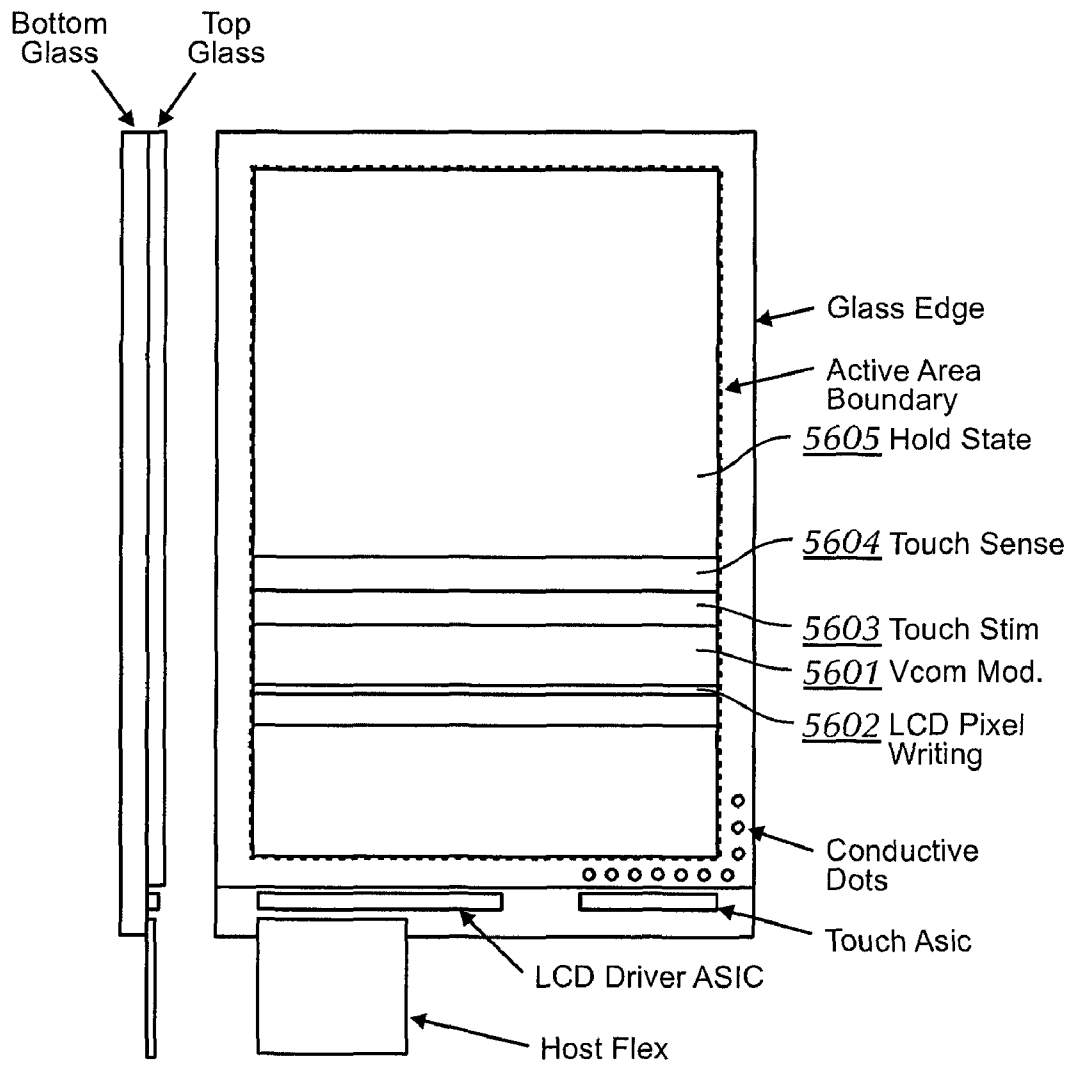

FIG. 56

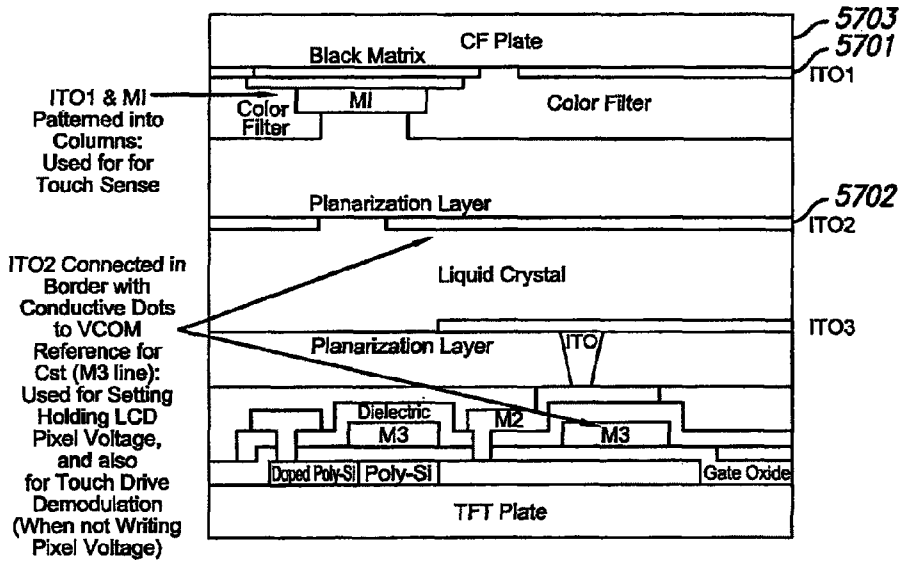

FIG. 57

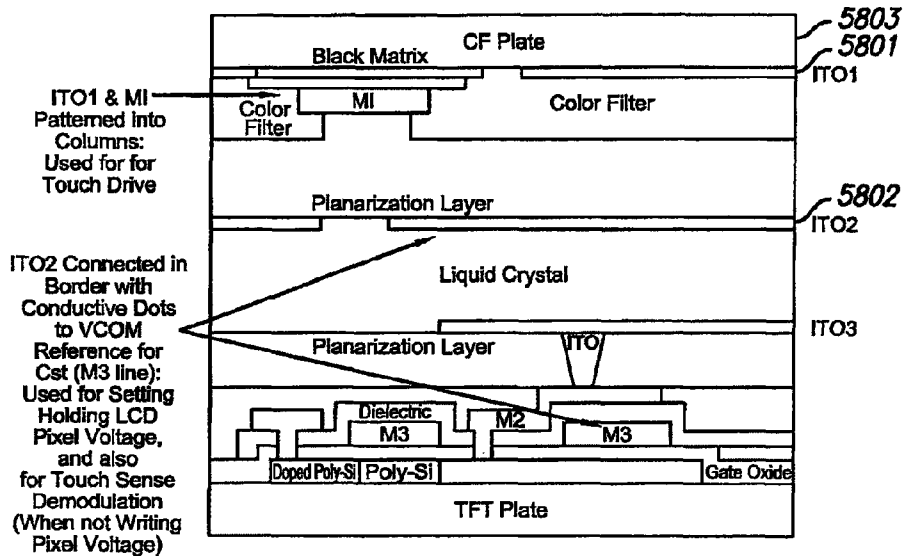

FIG. 58

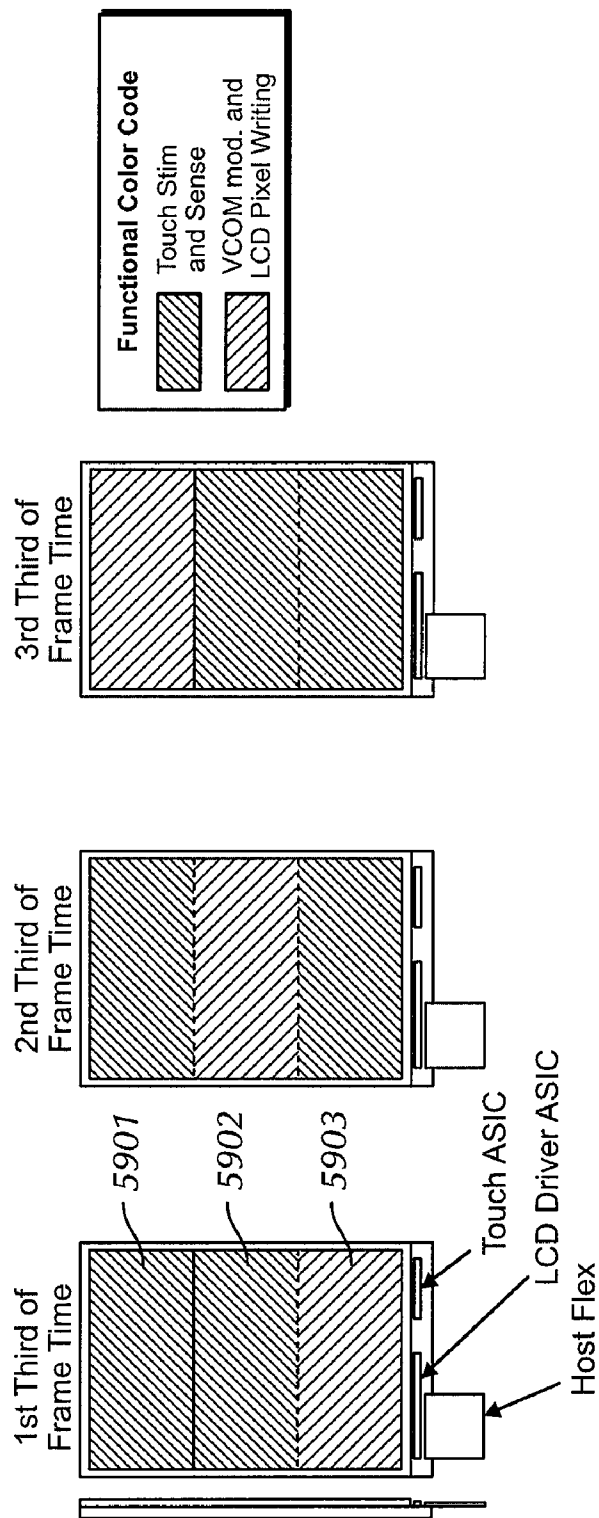

FIG. 59

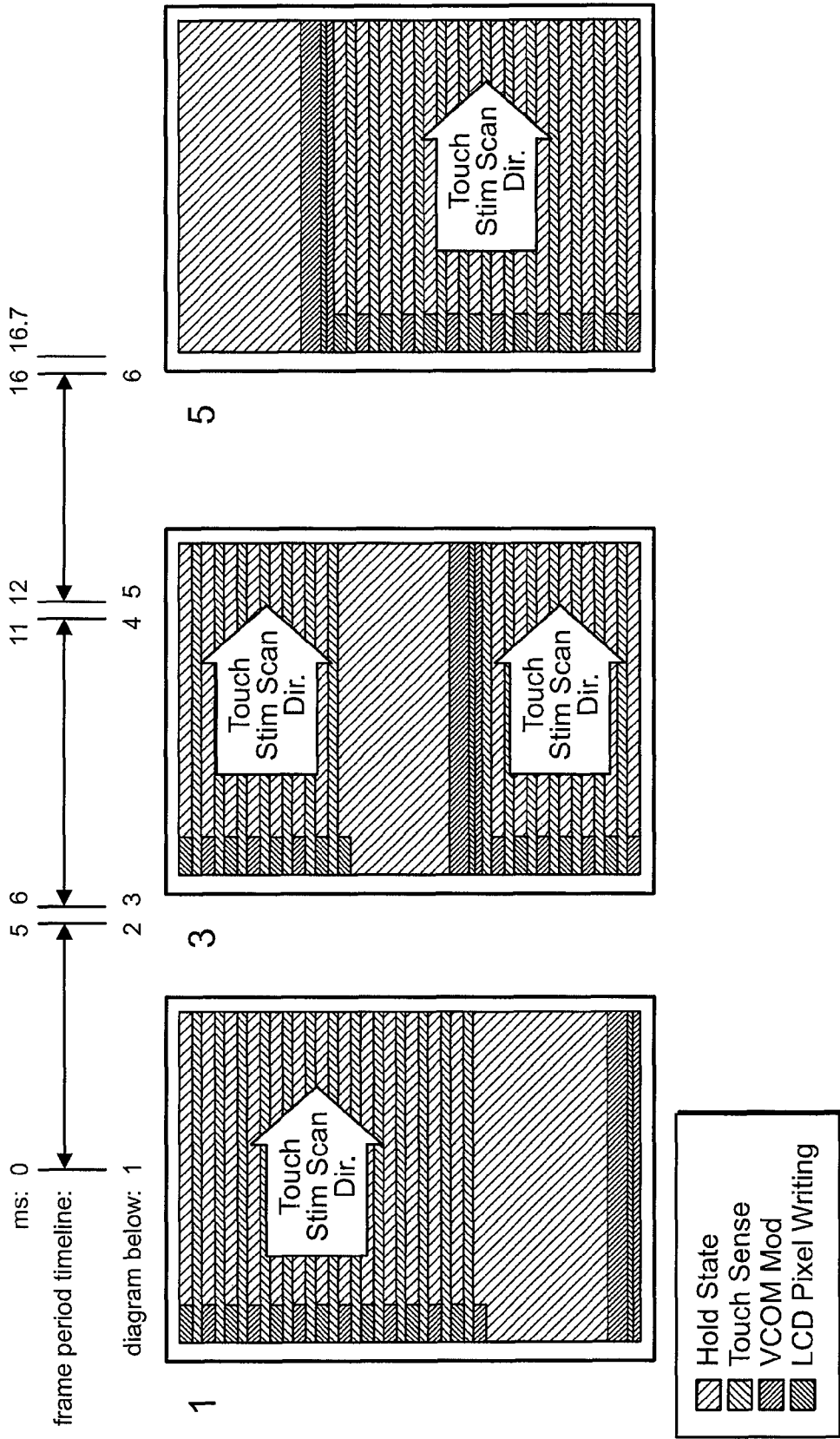

FIG. 60A

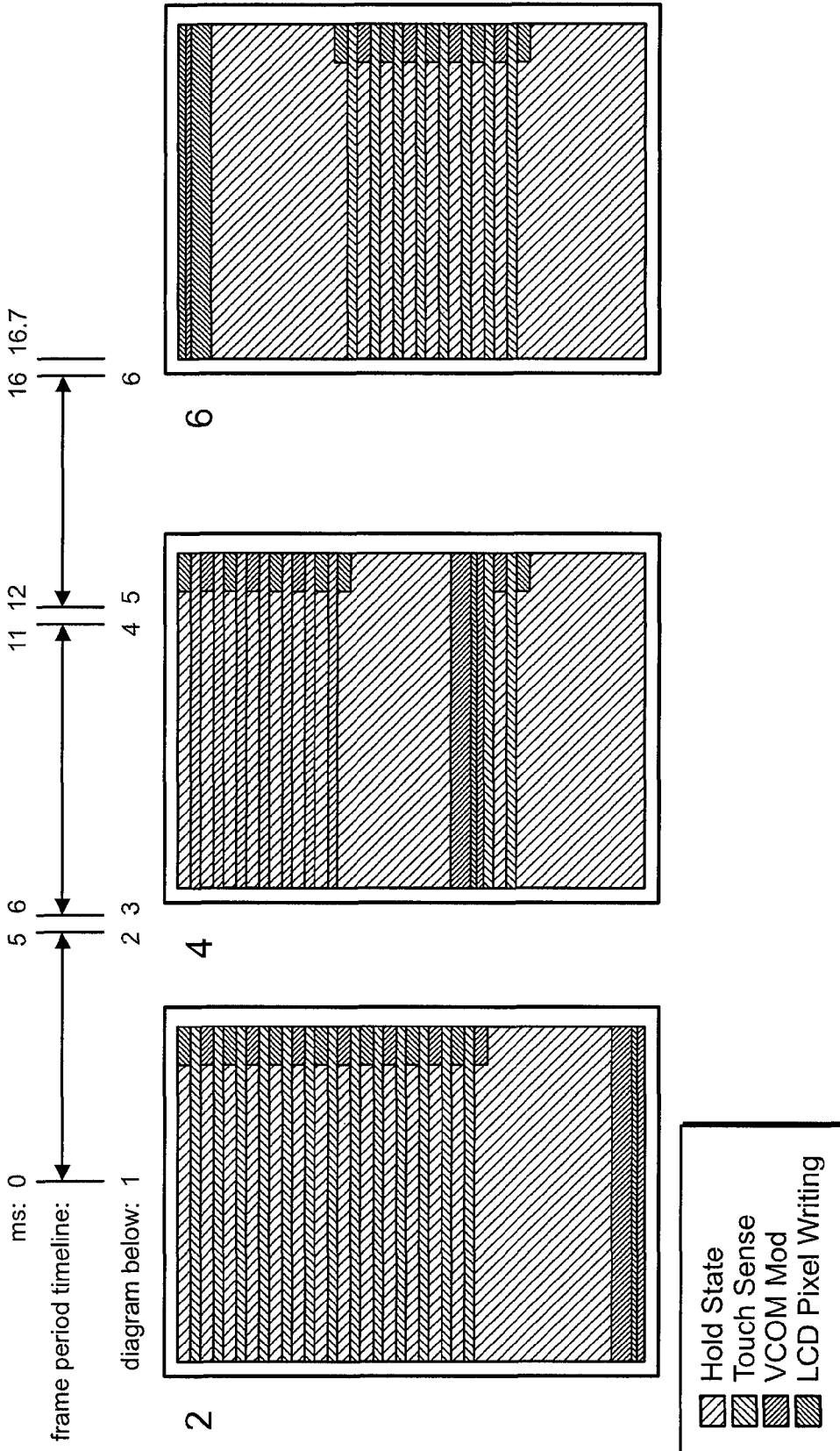

FIG. 60B

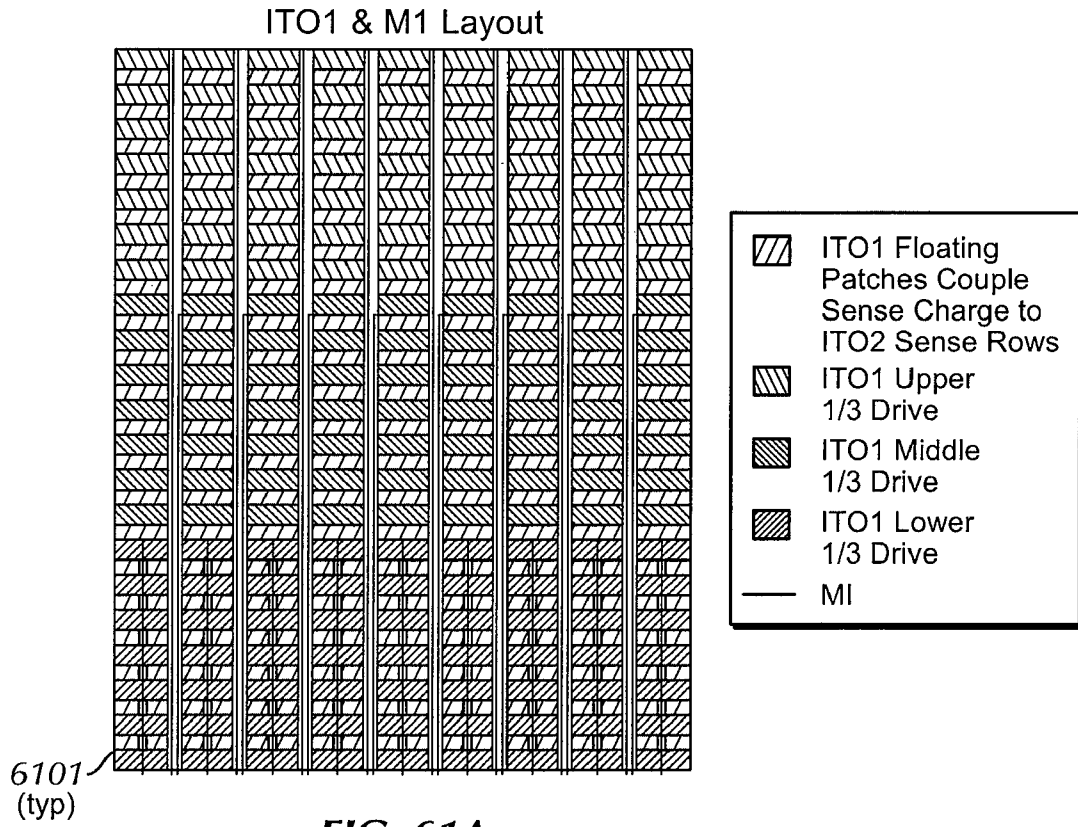

FIG. 61A

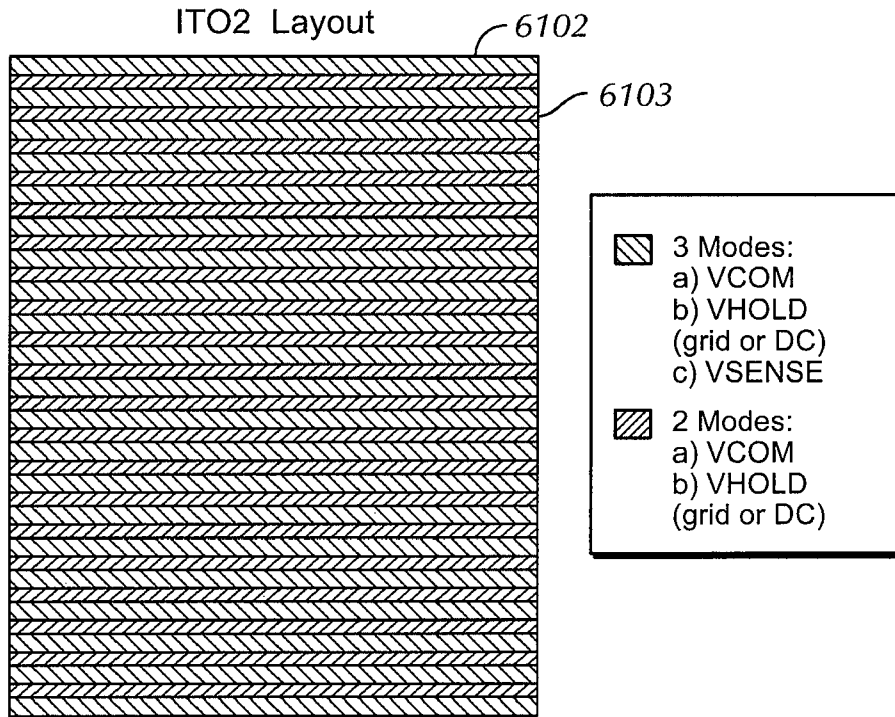

FIG. 61B

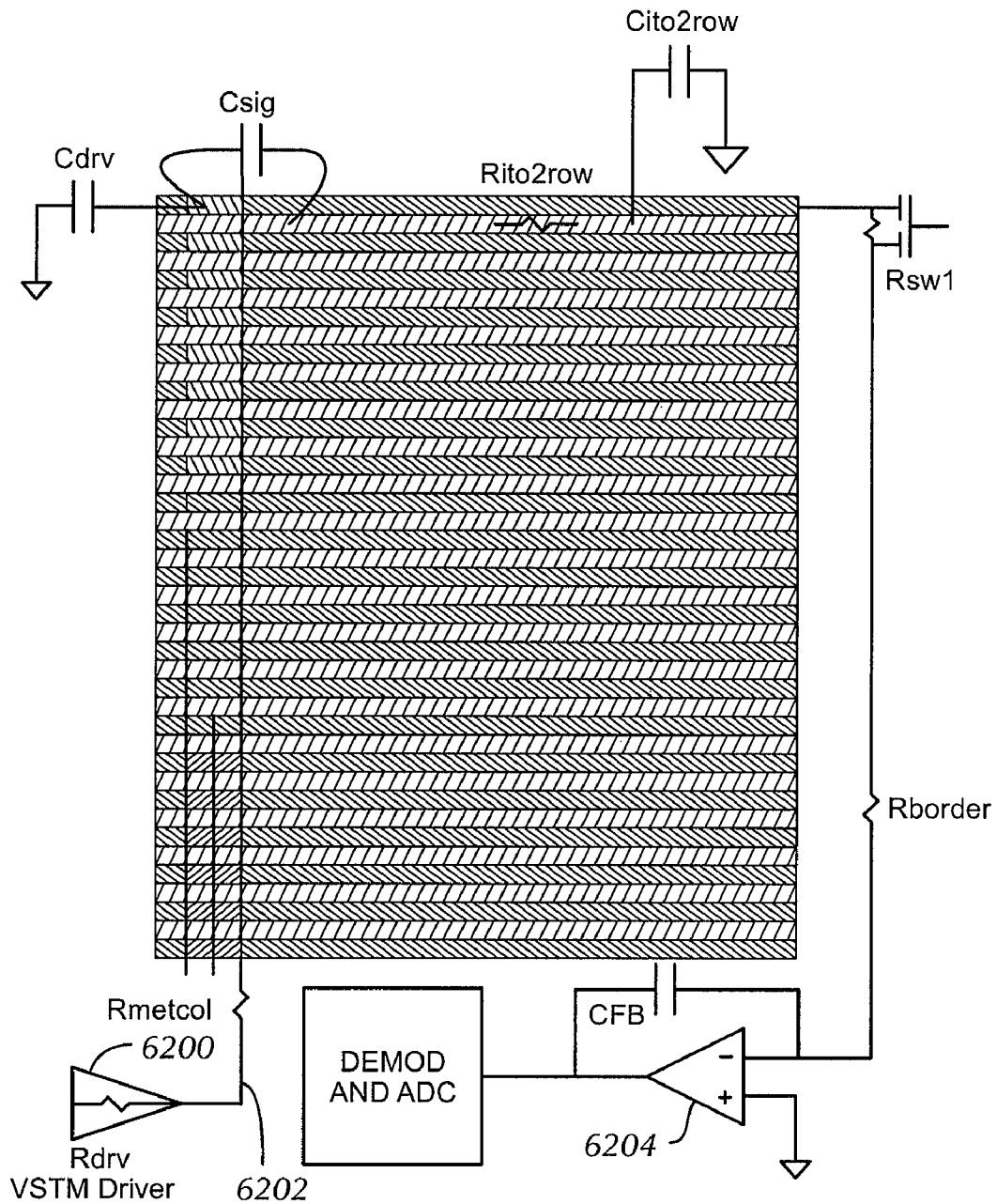

FIG. 62

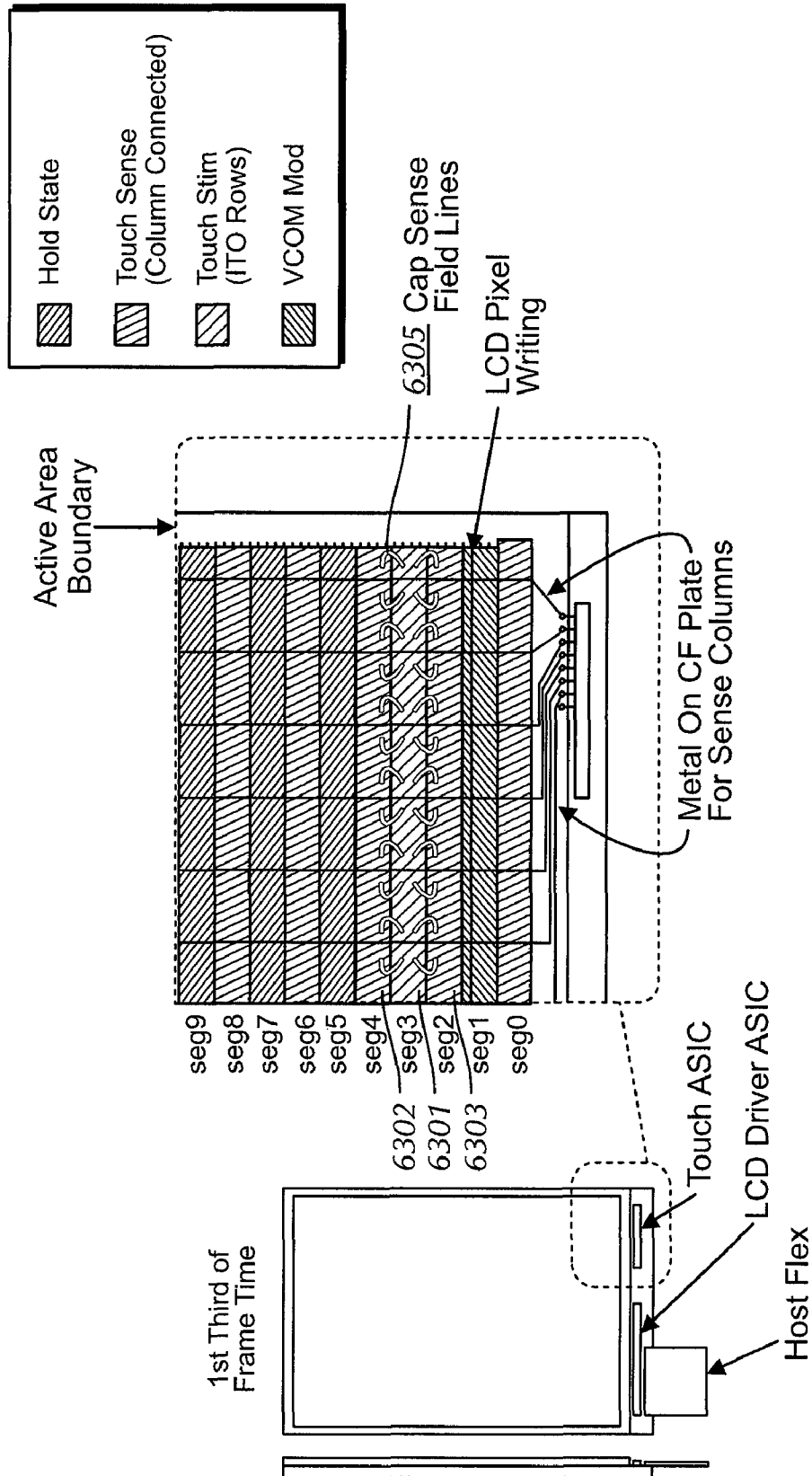

FIG. 63

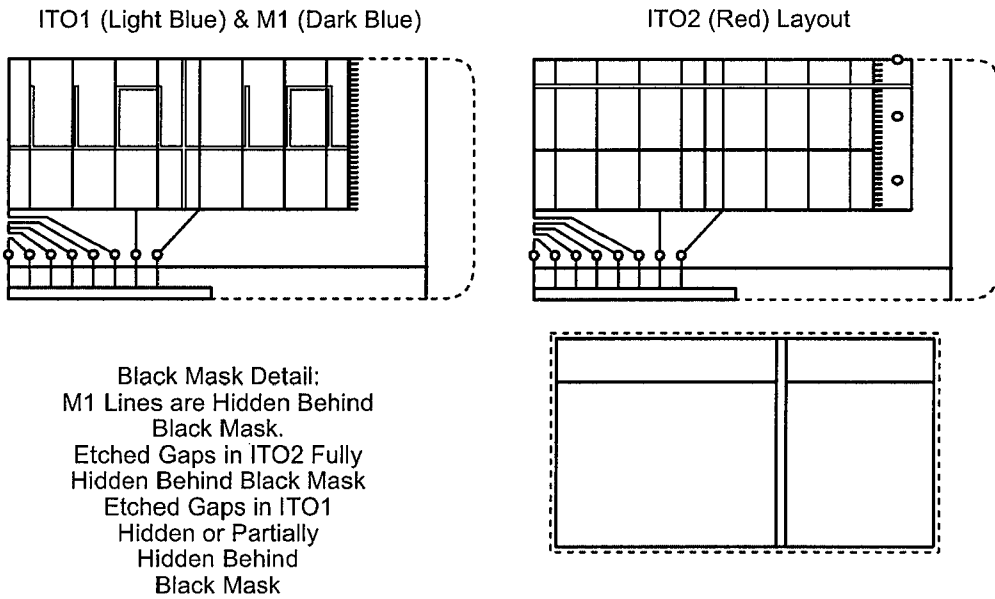

FIG. 64

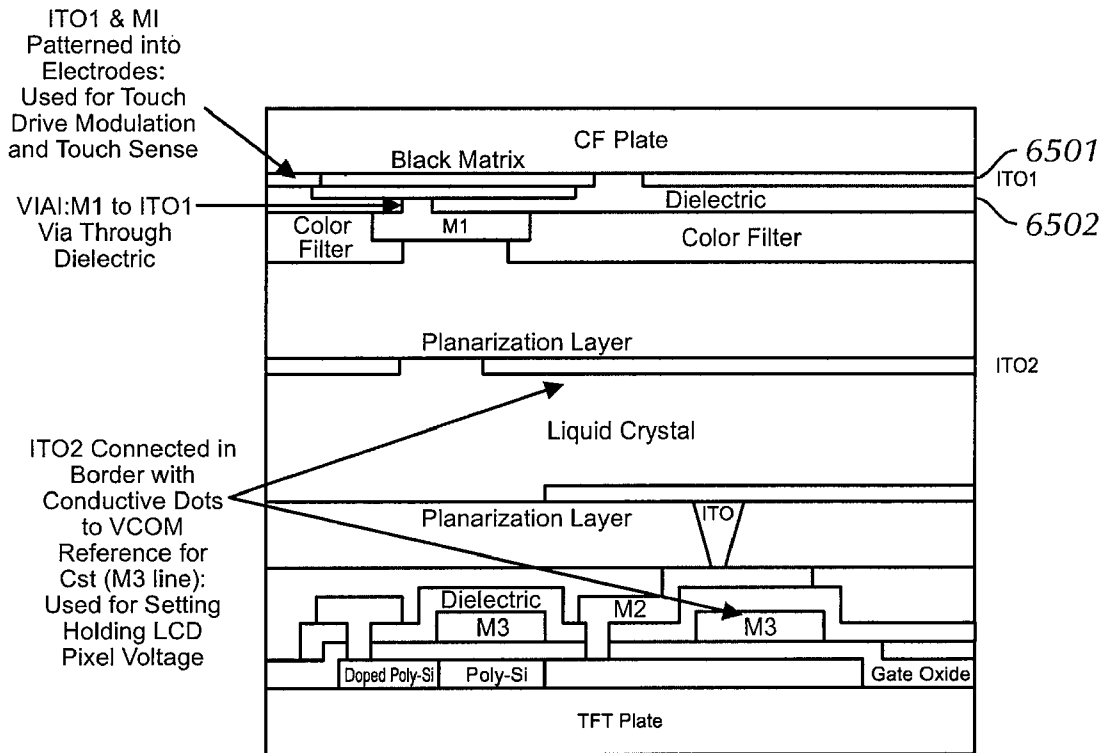

FIG. 65

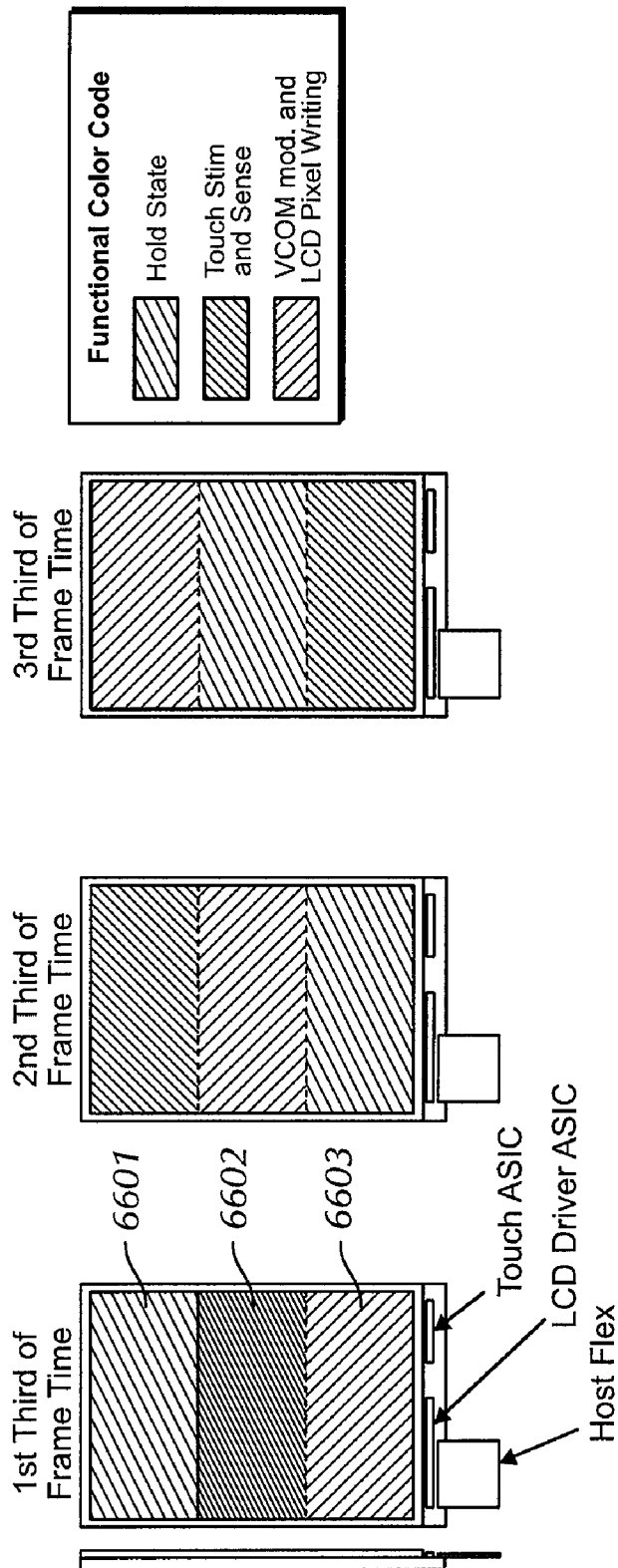

FIG. 66

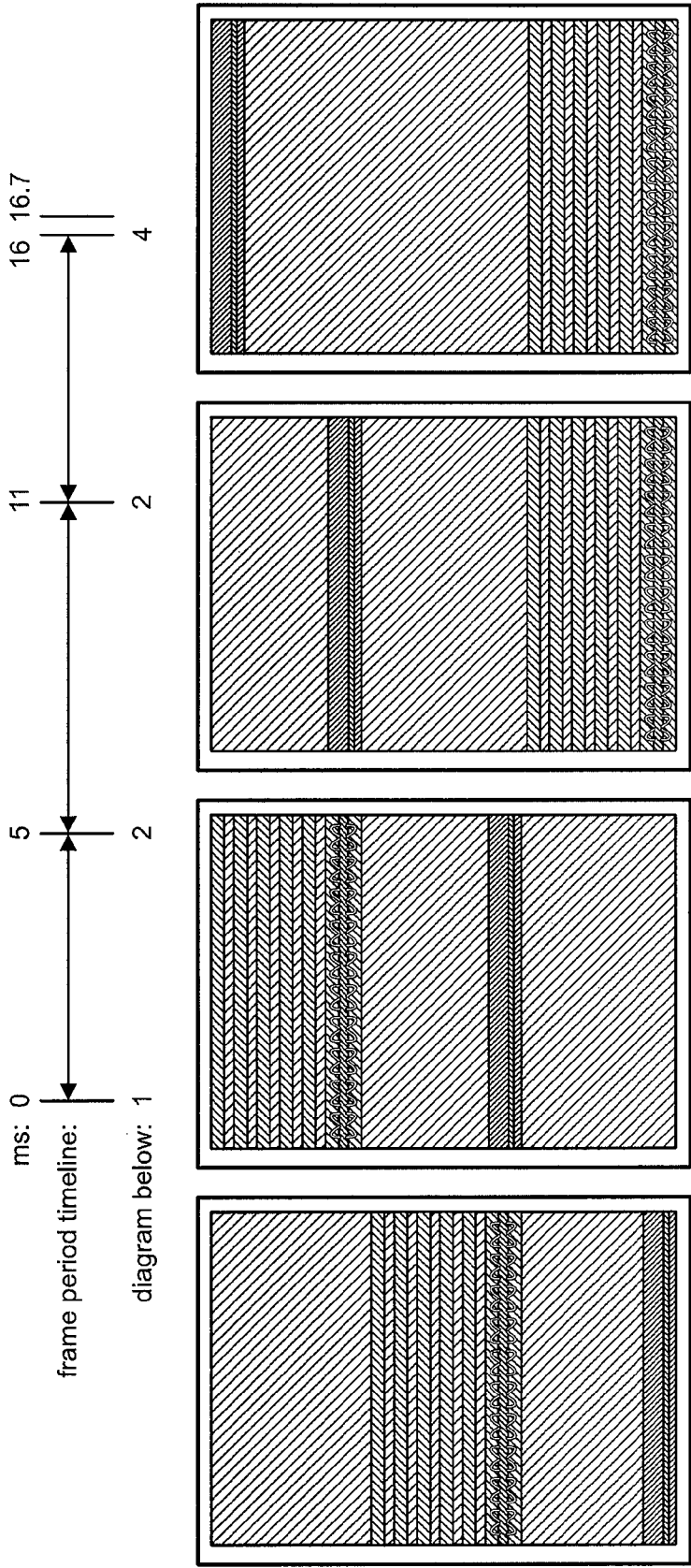

FIG. 67

- Hold State
- Touch Sense
- Touch Stim
- VCOM Mod.
- LCD Pixel Writing
- Cap Sense Field Lines

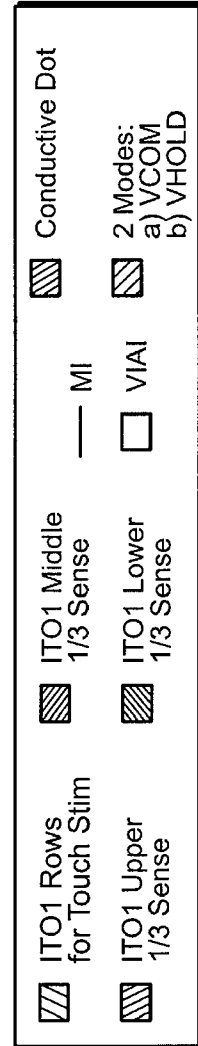
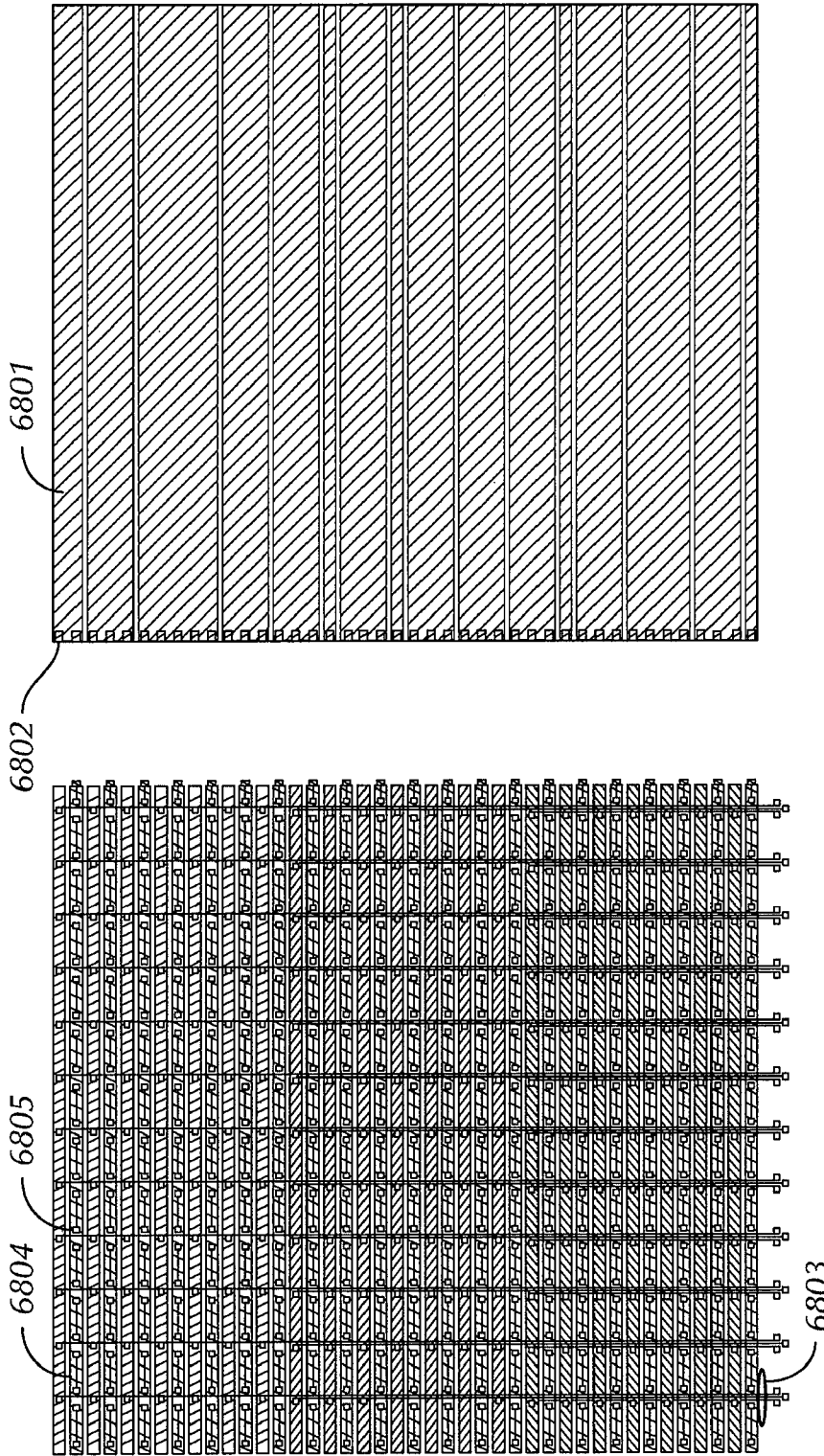

FIG. 68

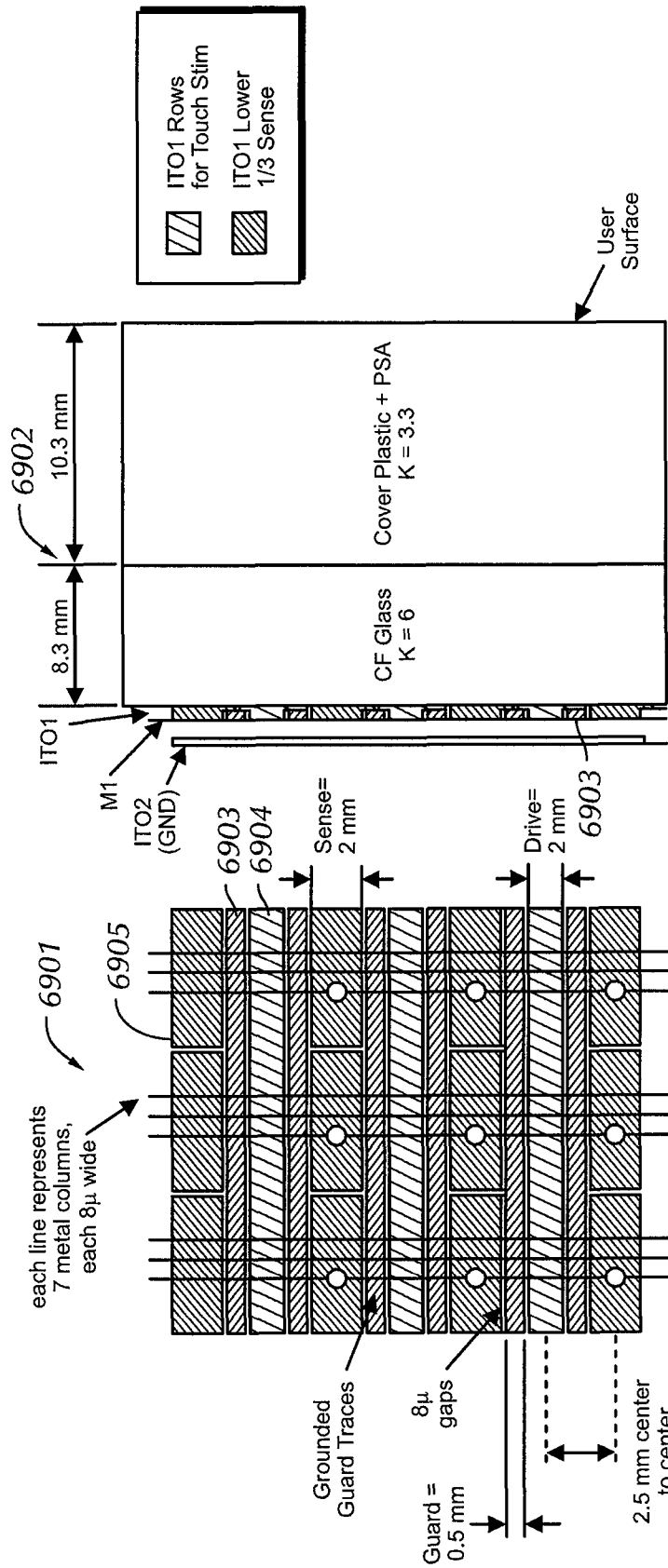

FIG. 69

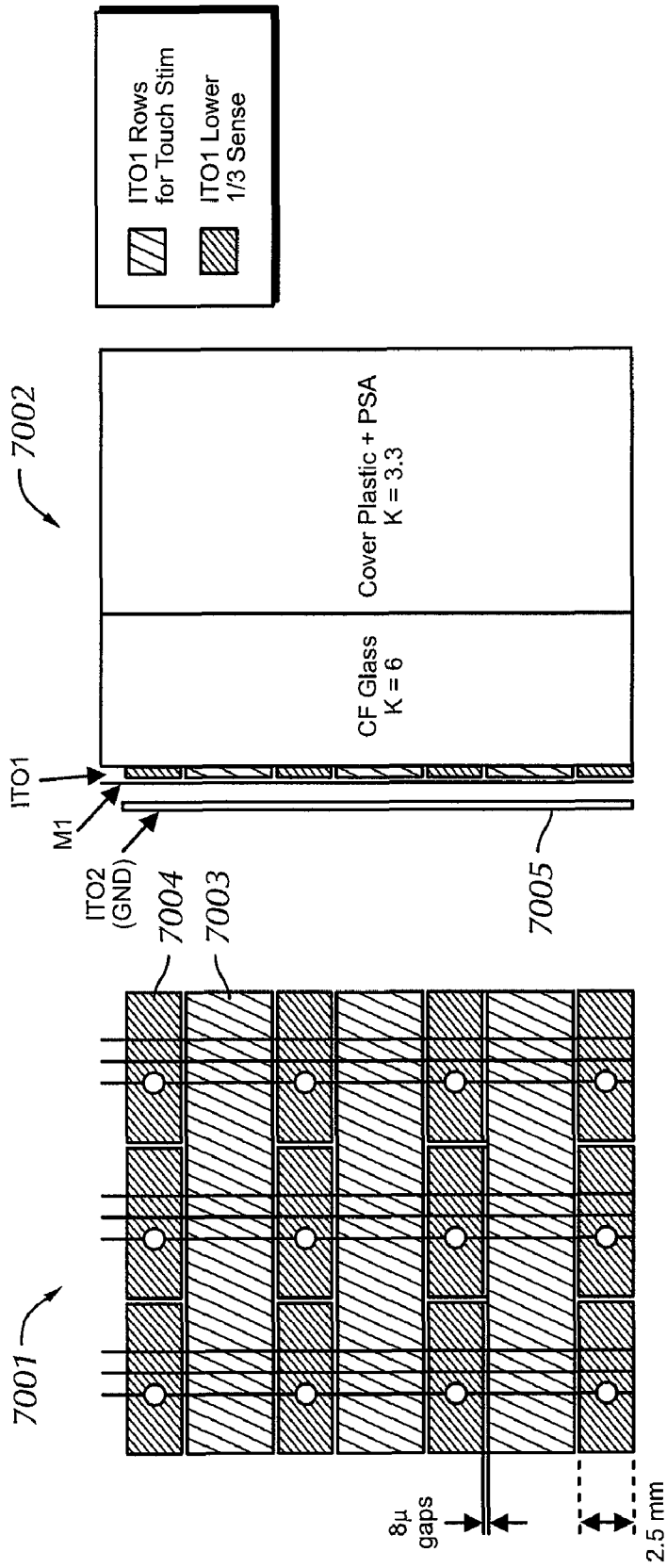

FIG. 70

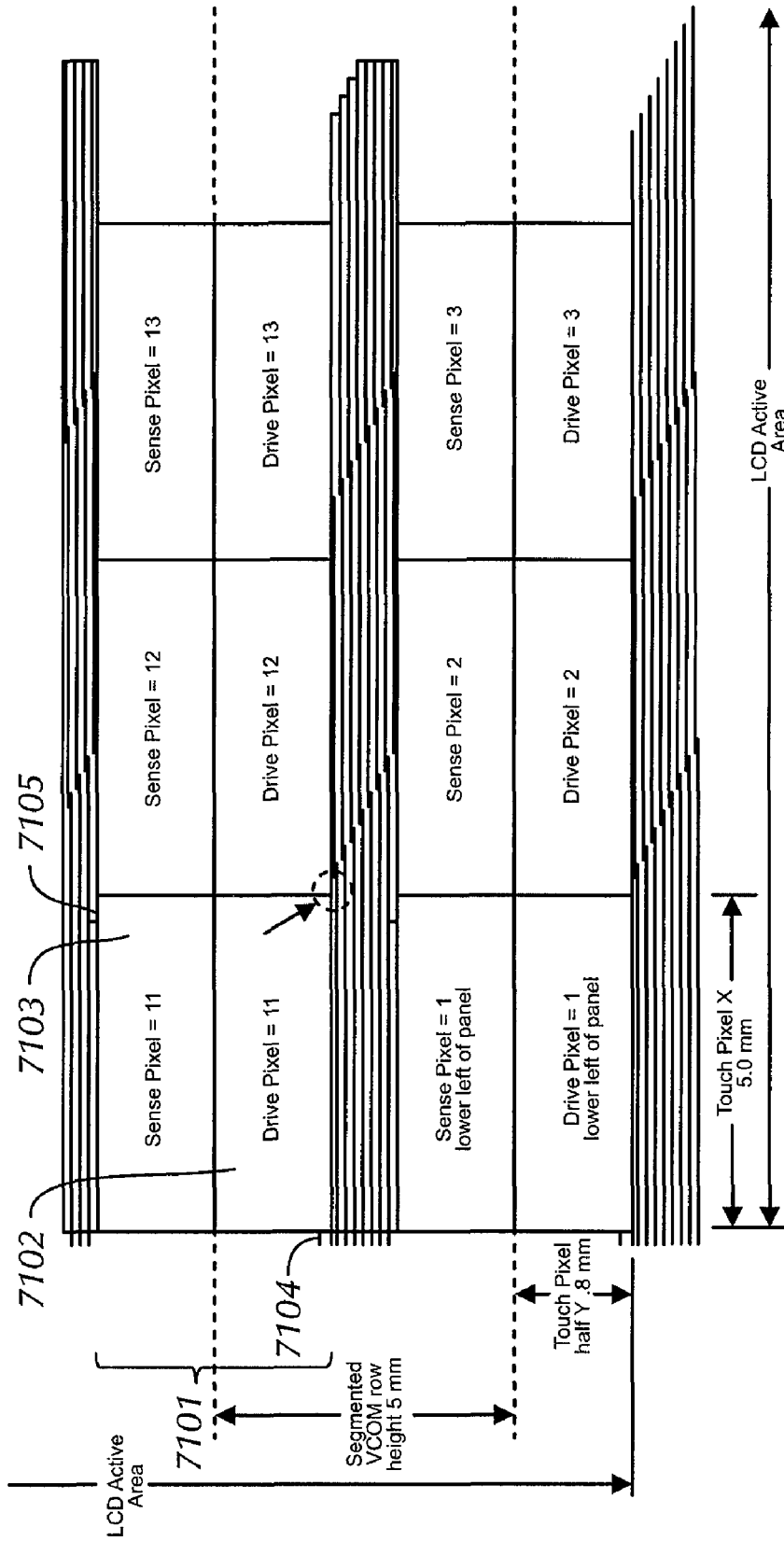

FIG. 71

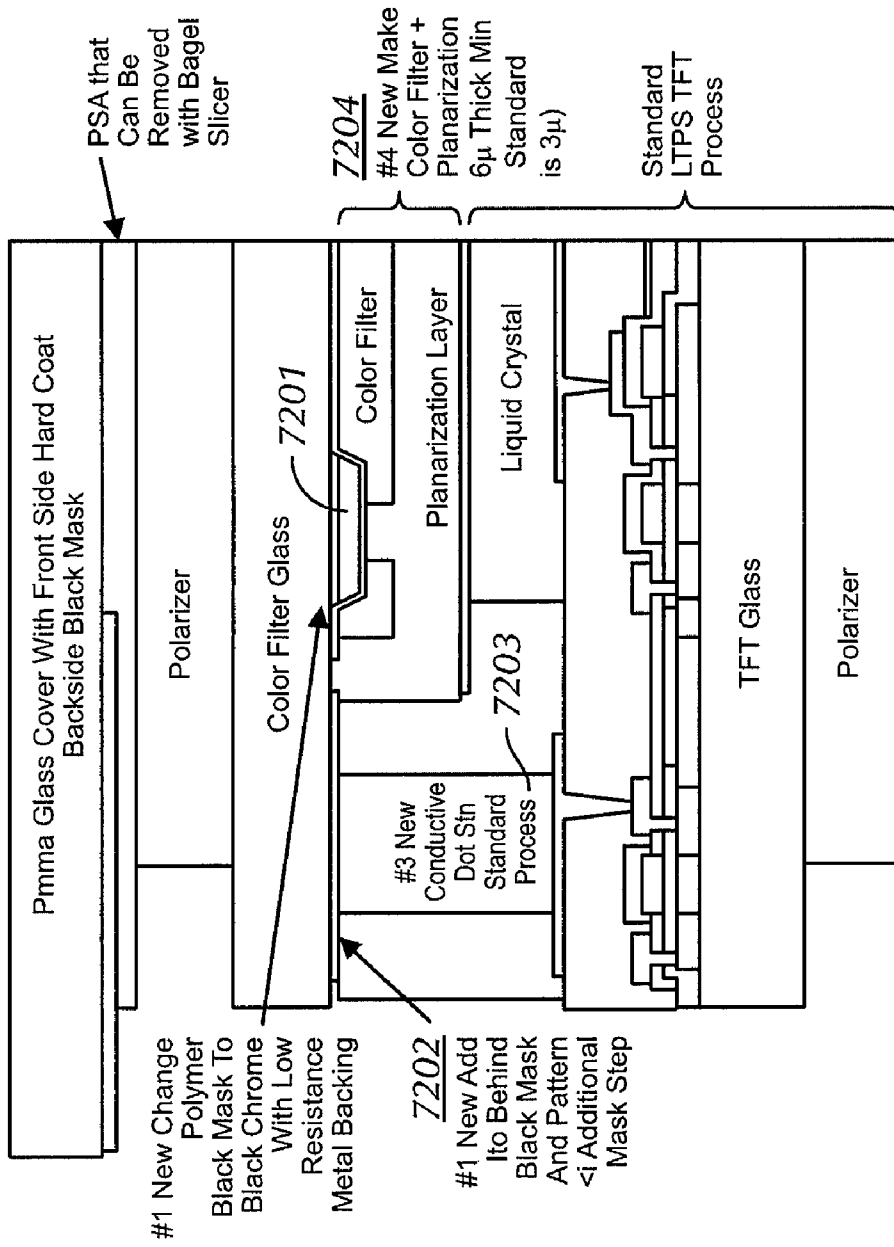

FIG. 72

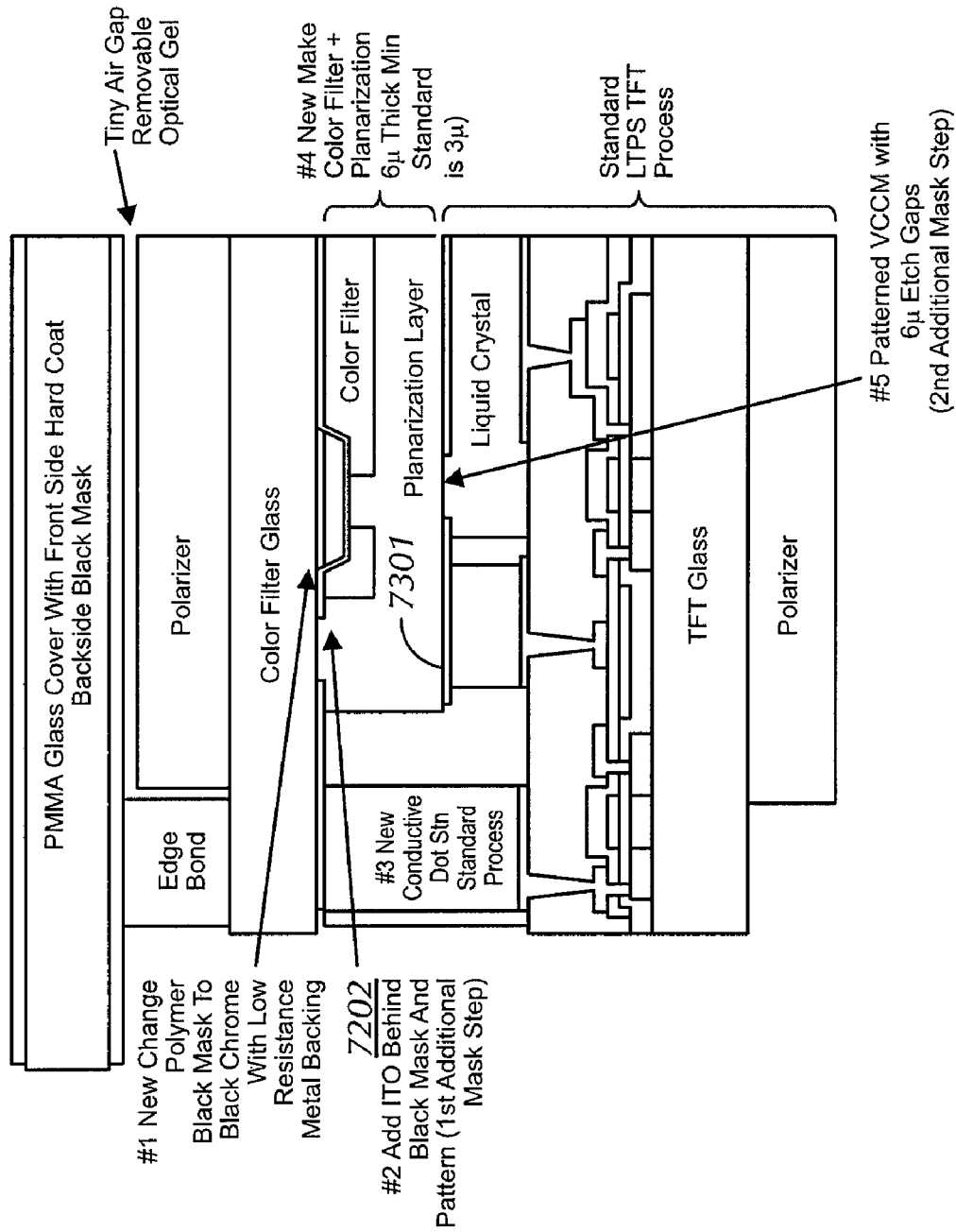

FIG. 73

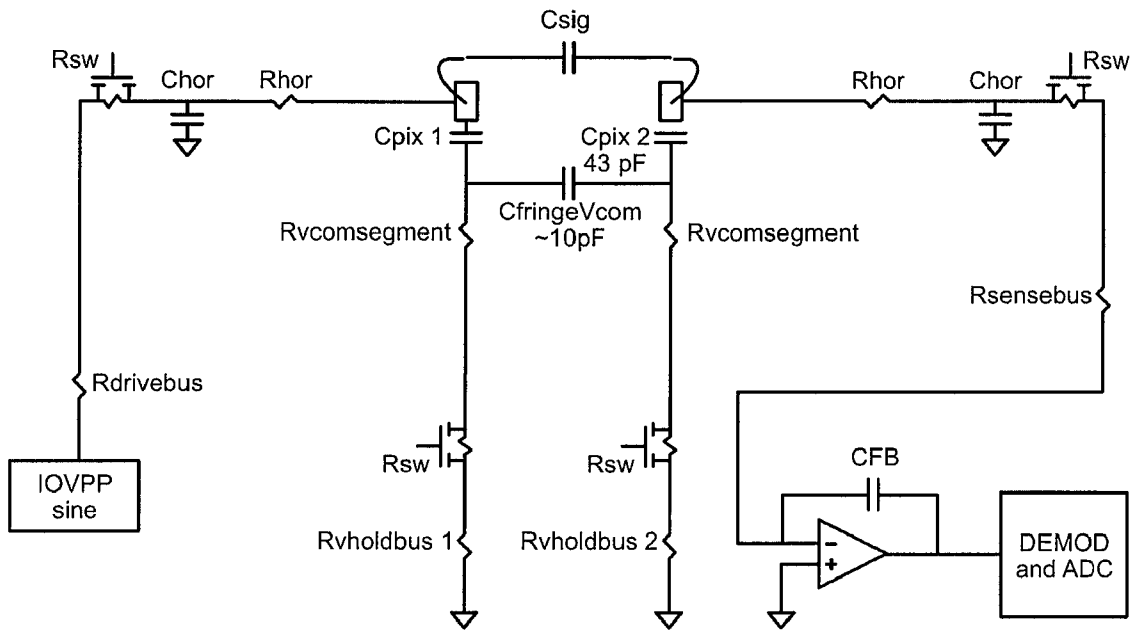

FIG. 74

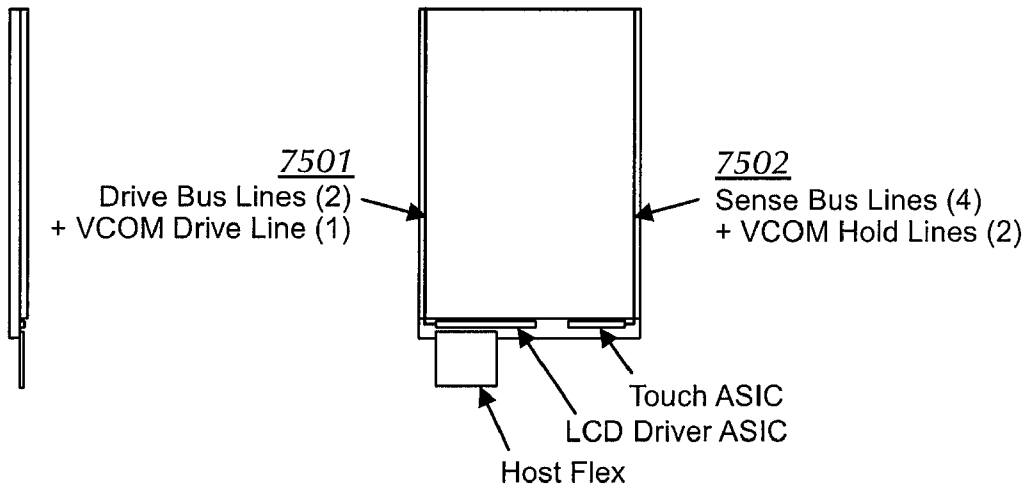

FIG. 75

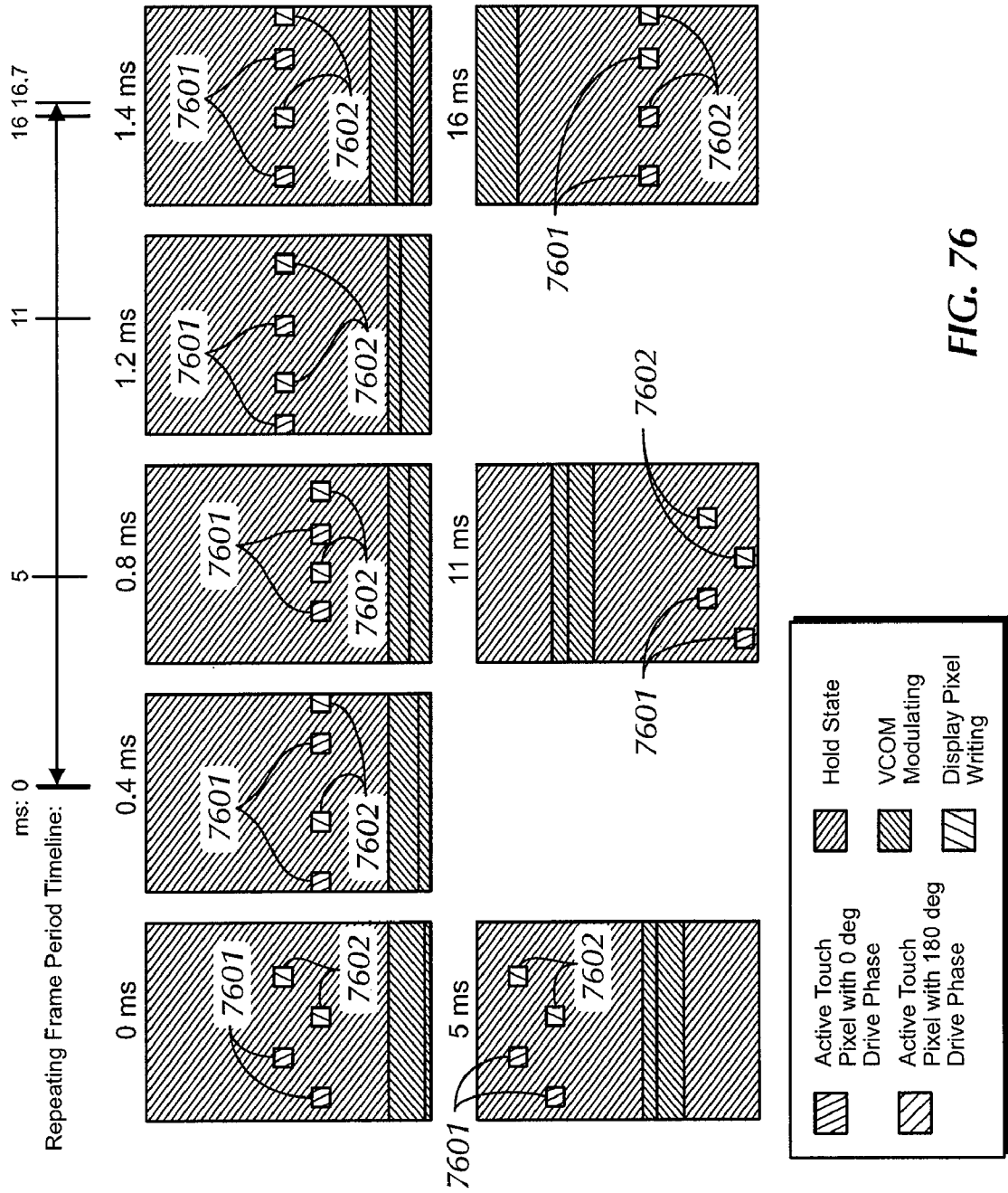

FIG. 76

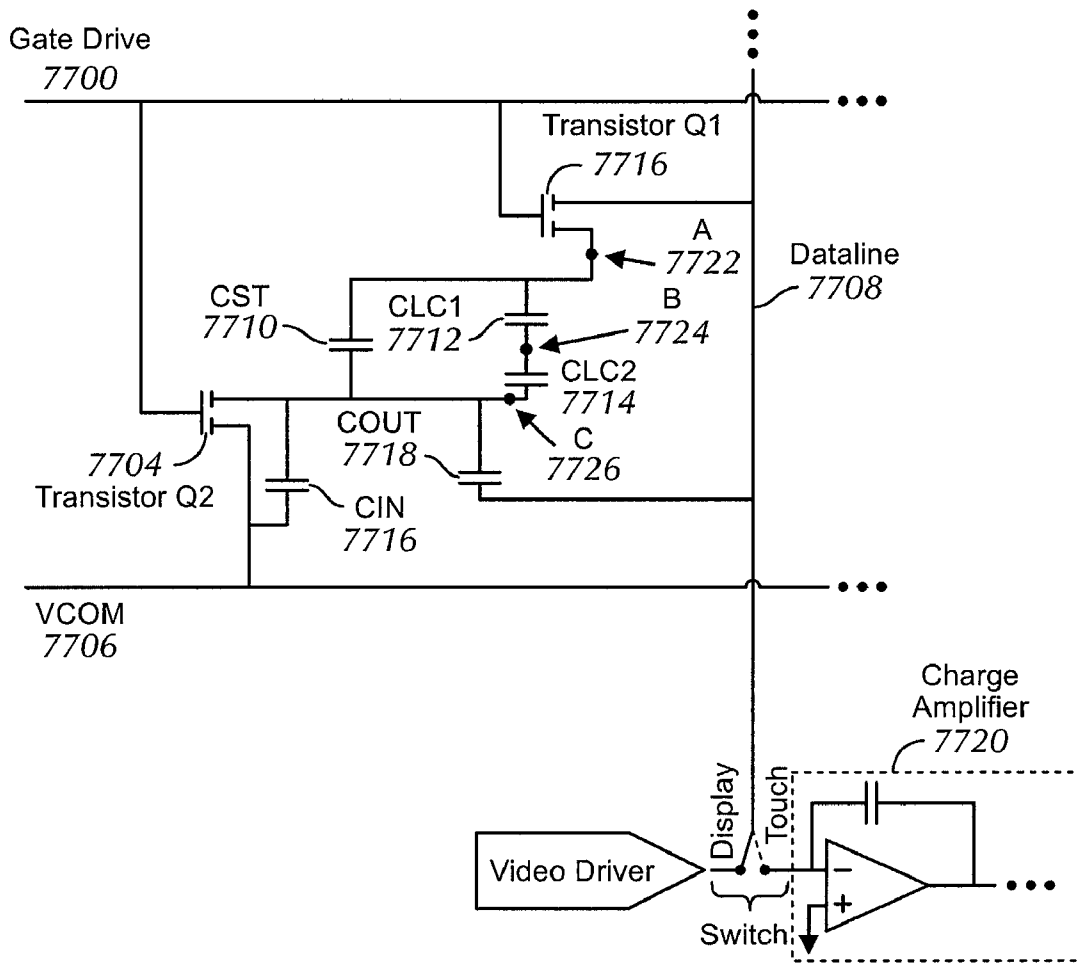

FIG. 77

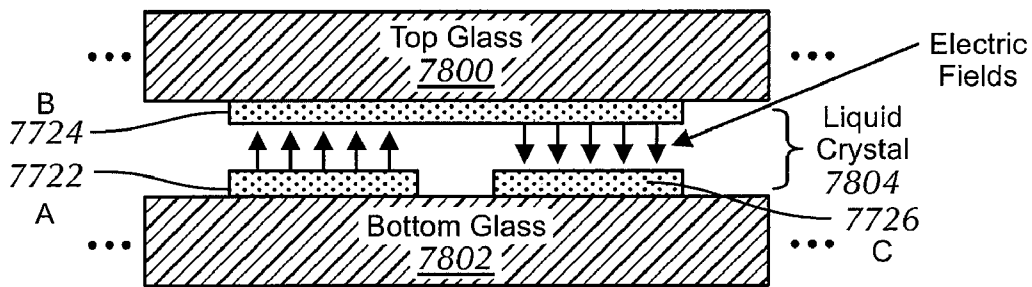

FIG. 78

Subpixel Stackup

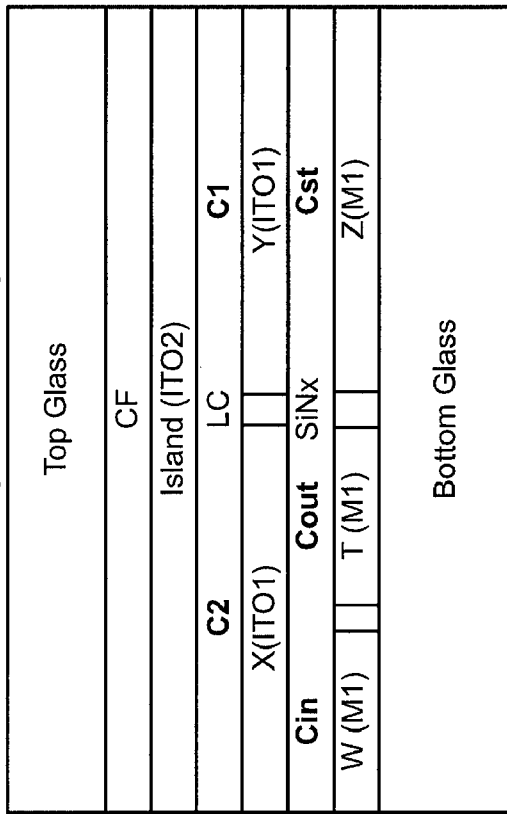

FIG. 79

Wiring to T,W,X,Y,Z structures

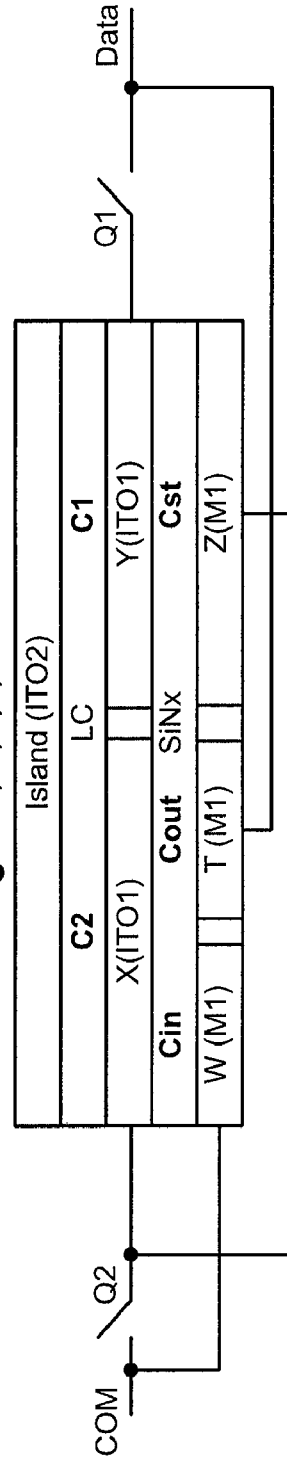
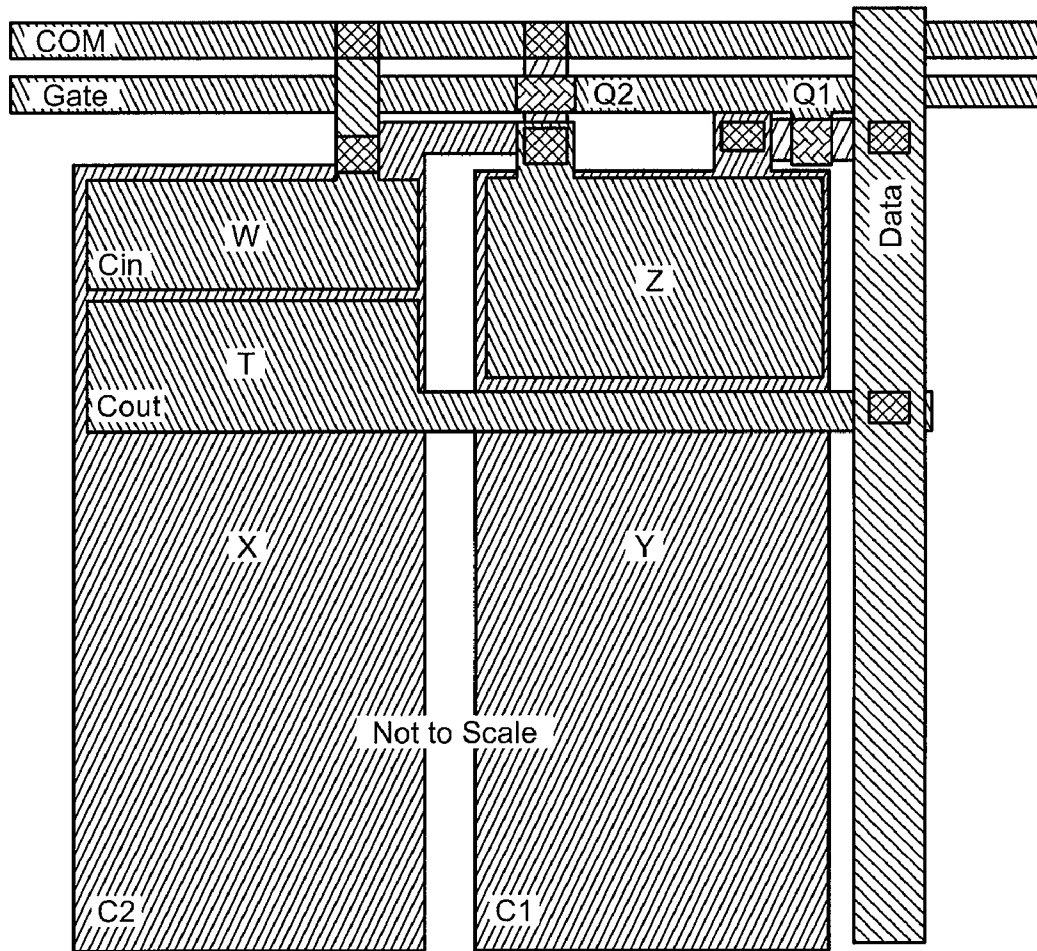

FIG. 80



Subpixel Layout

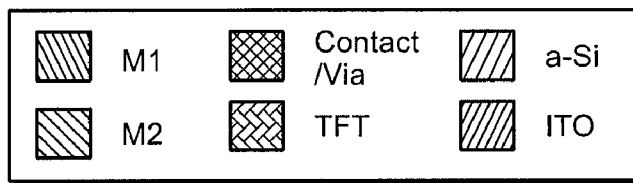

FIG. 81

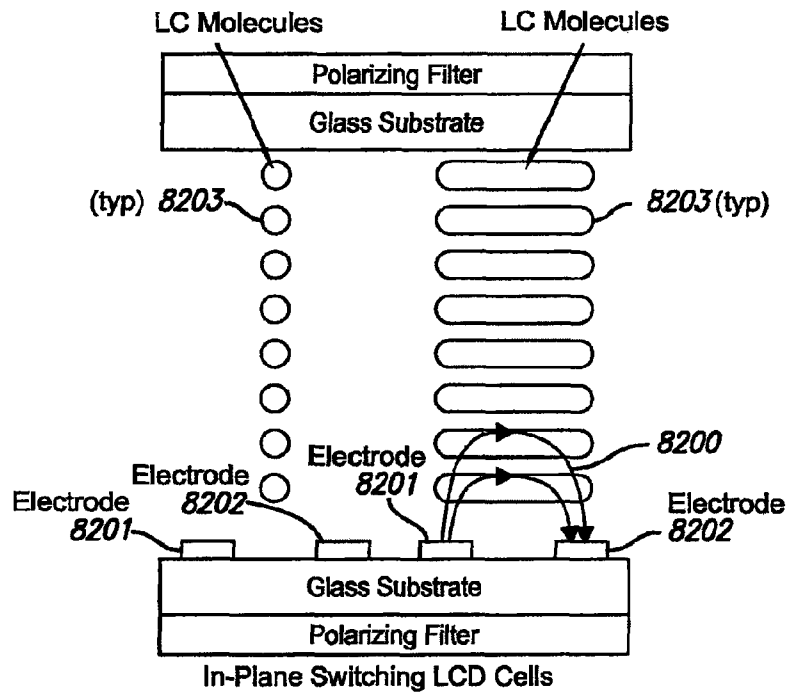

FIG. 82

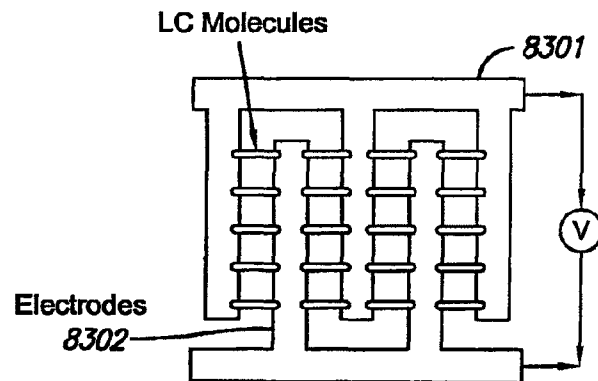

FIG. 83

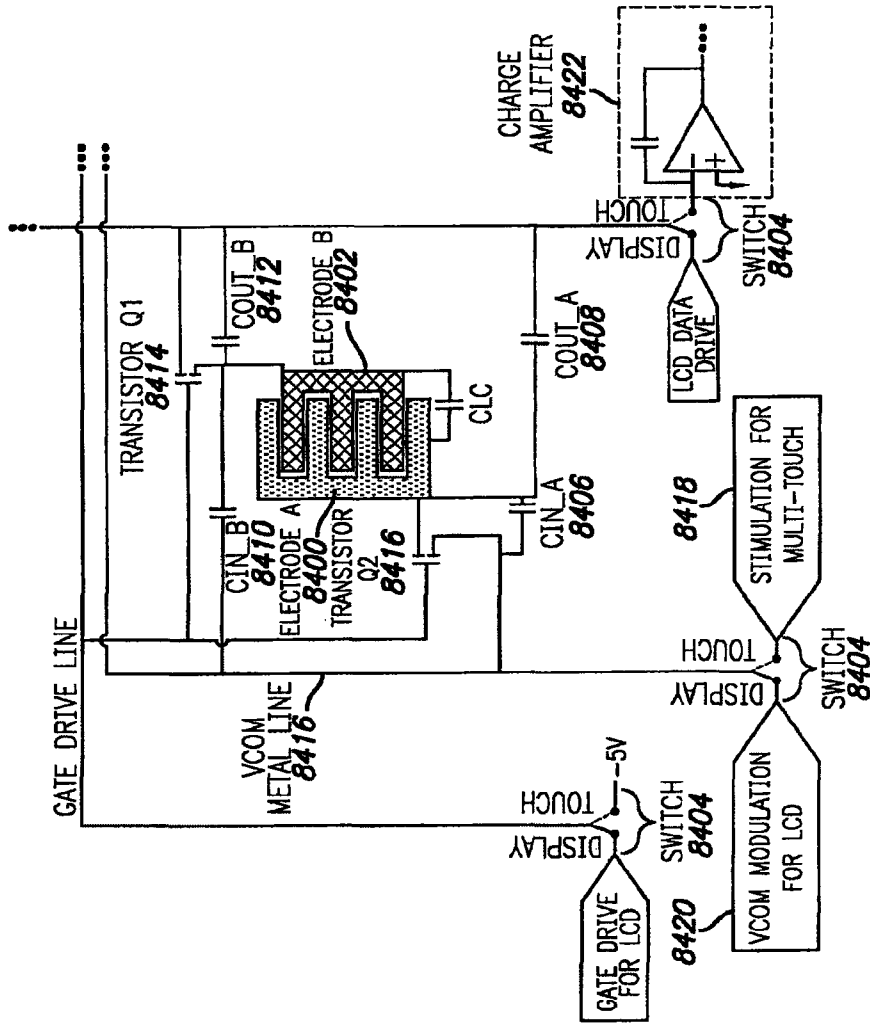

FIG. 84

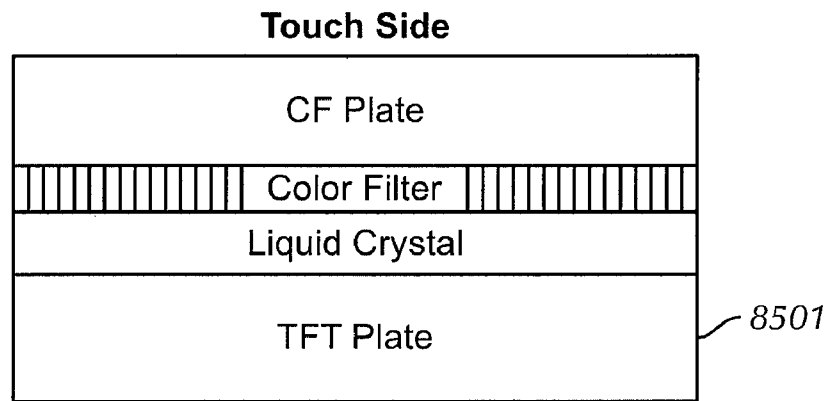

FIG. 85

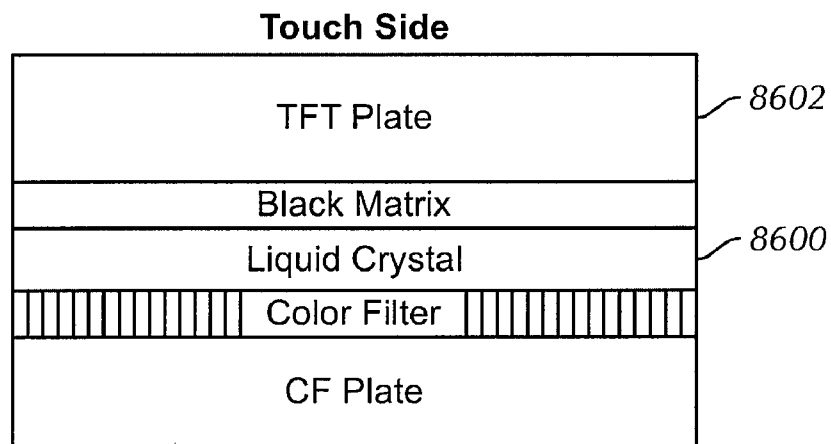

FIG. 86

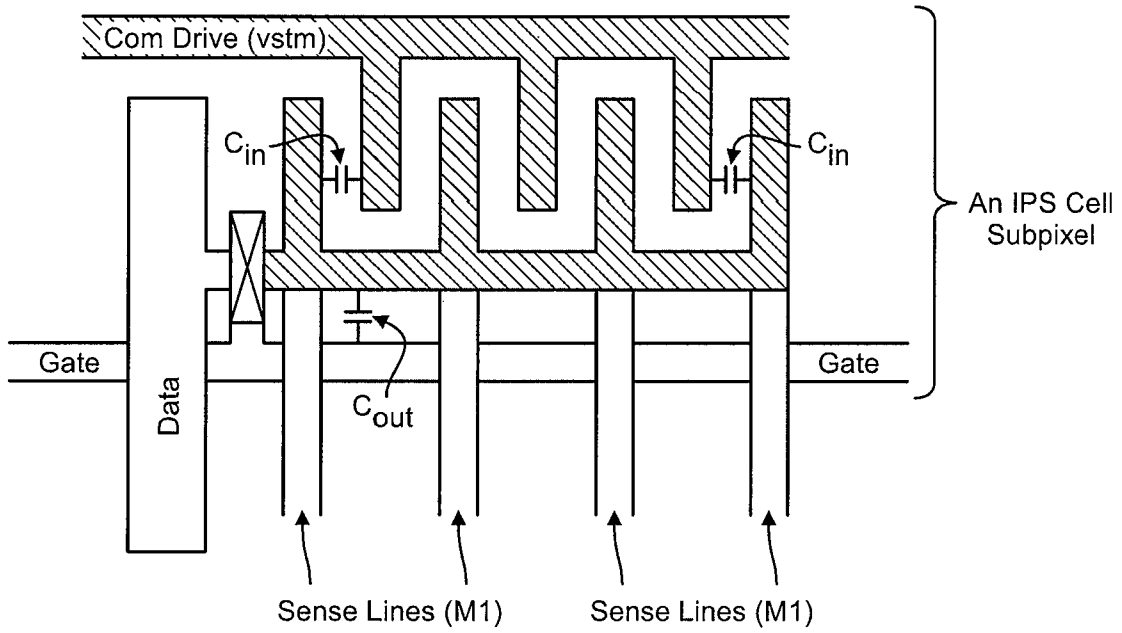

FIG. 87

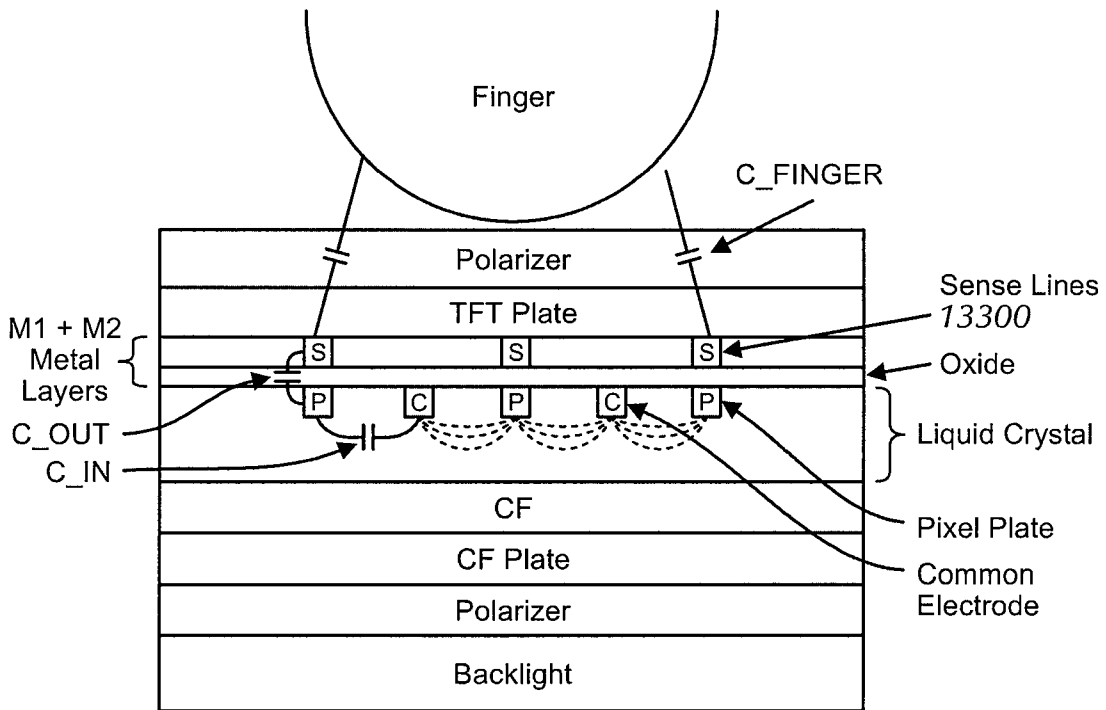

FIG. 88

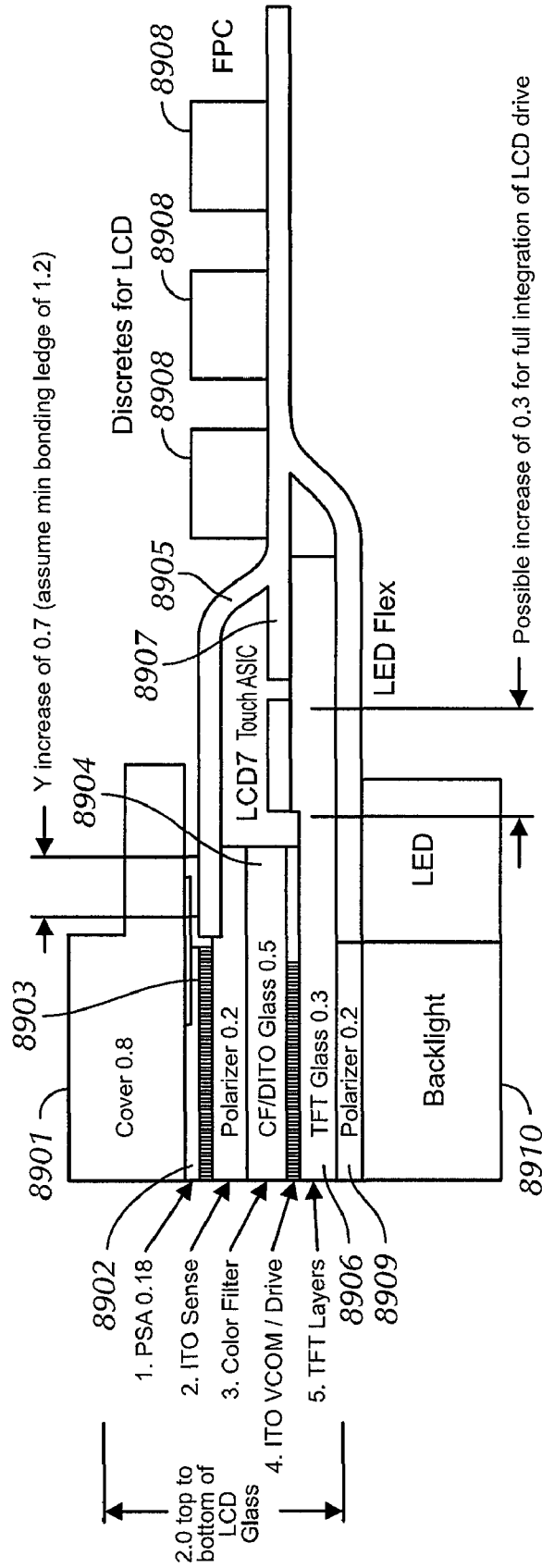

FIG. 89

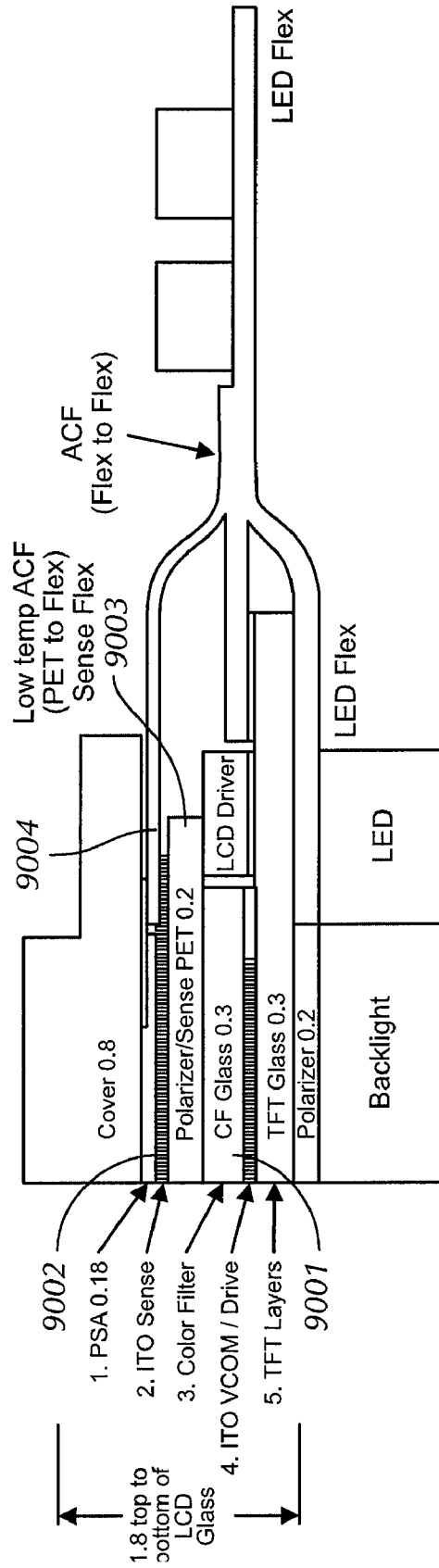

FIG. 90

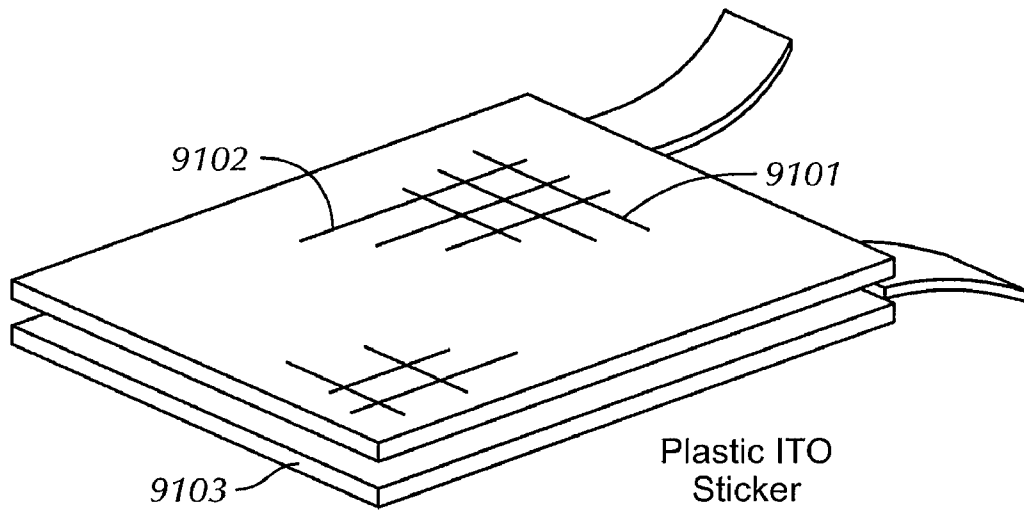

FIG. 91

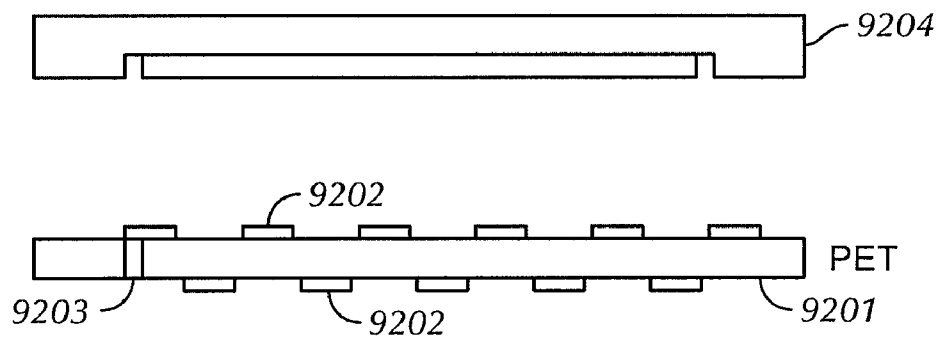

FIG. 92

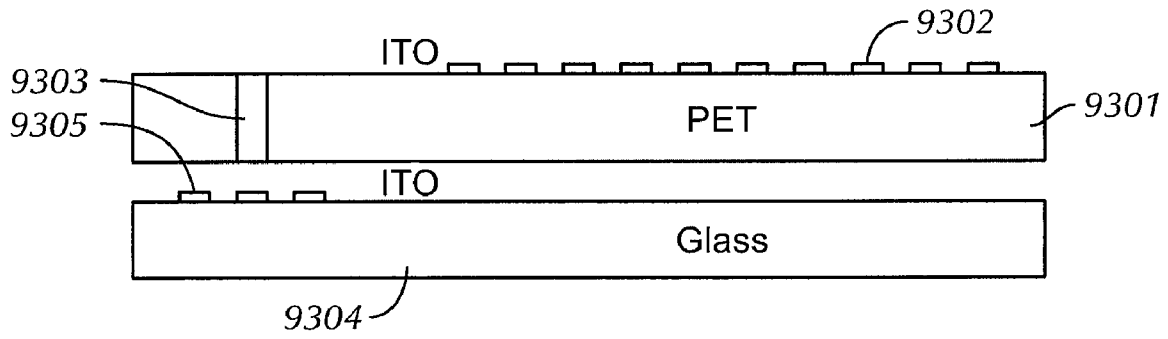

FIG. 93

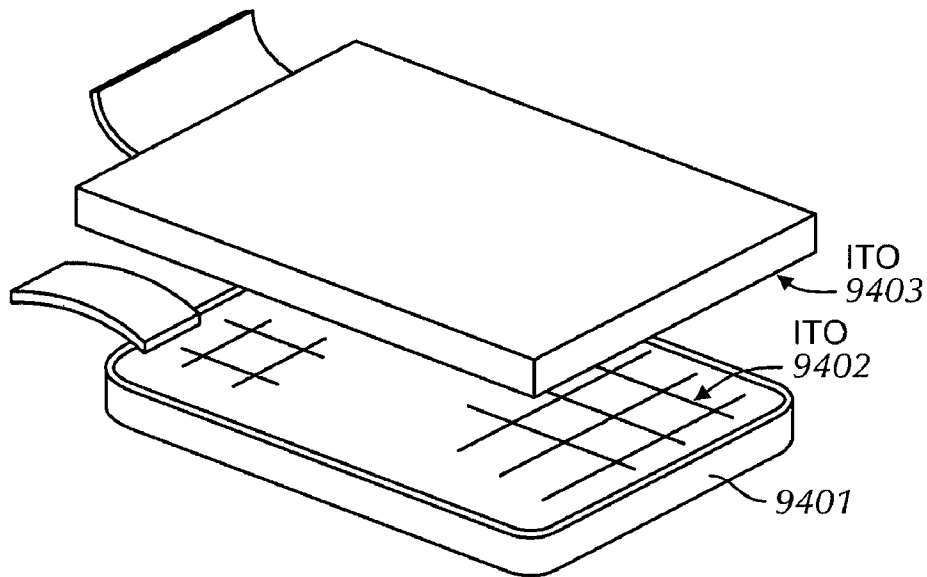

FIG. 94

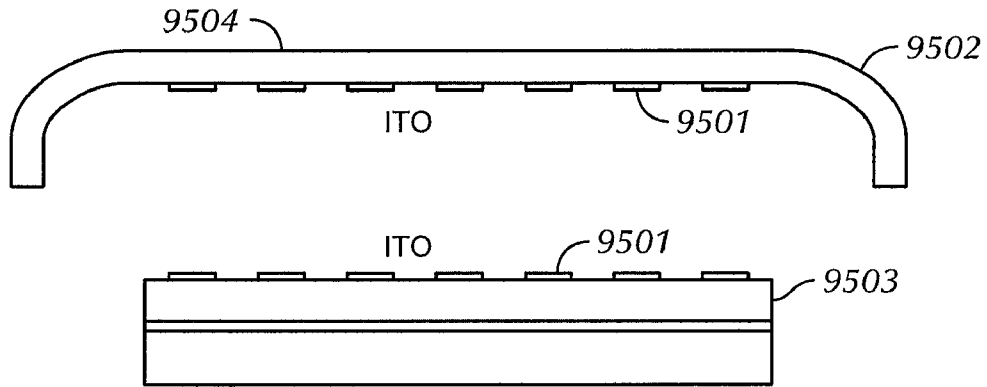

FIG. 95

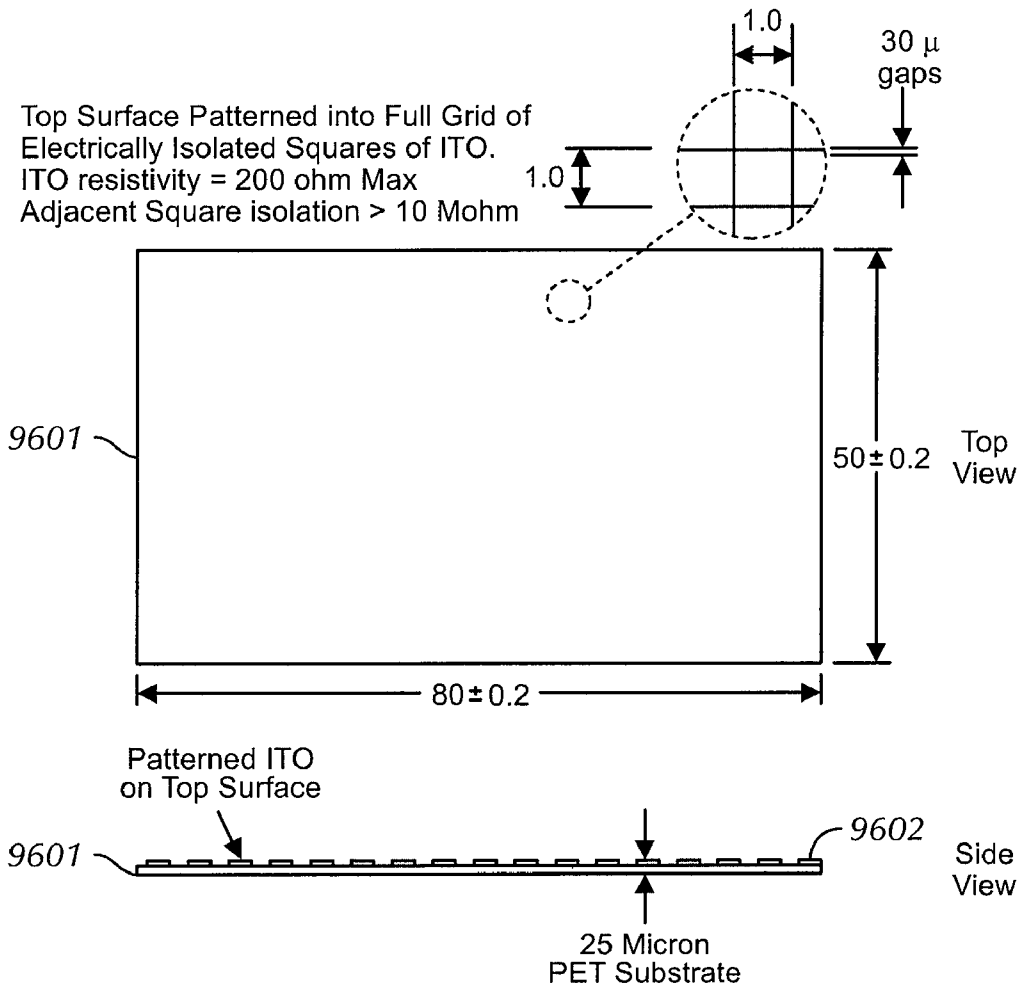

FIG. 96

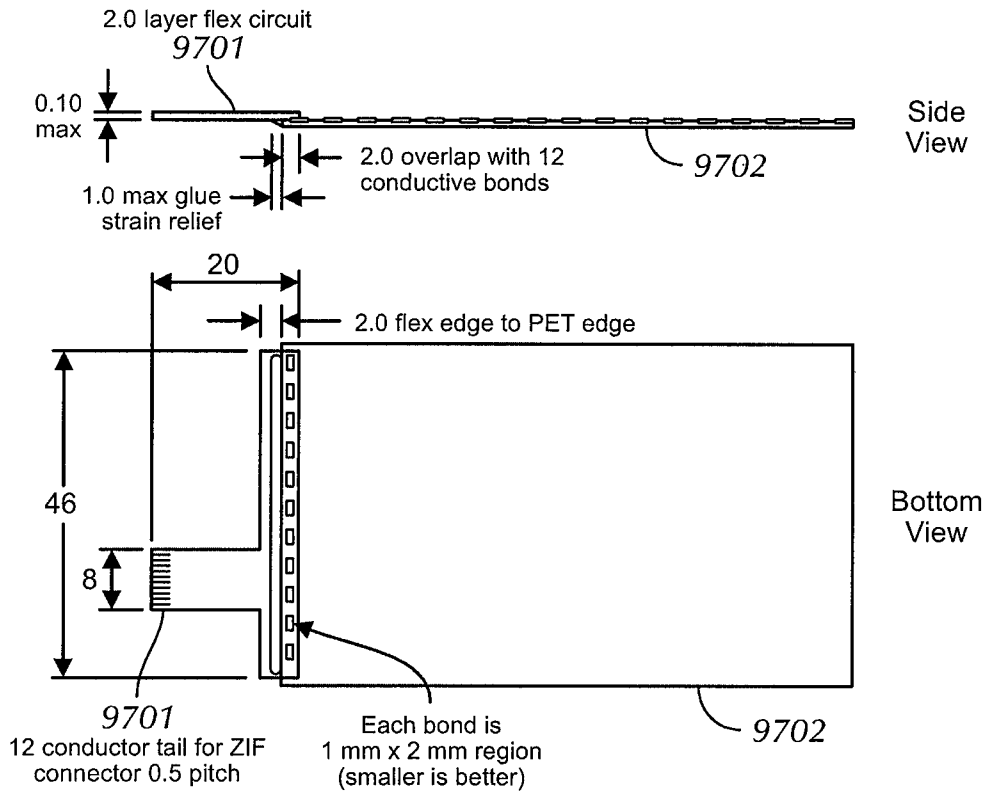

FIG. 97

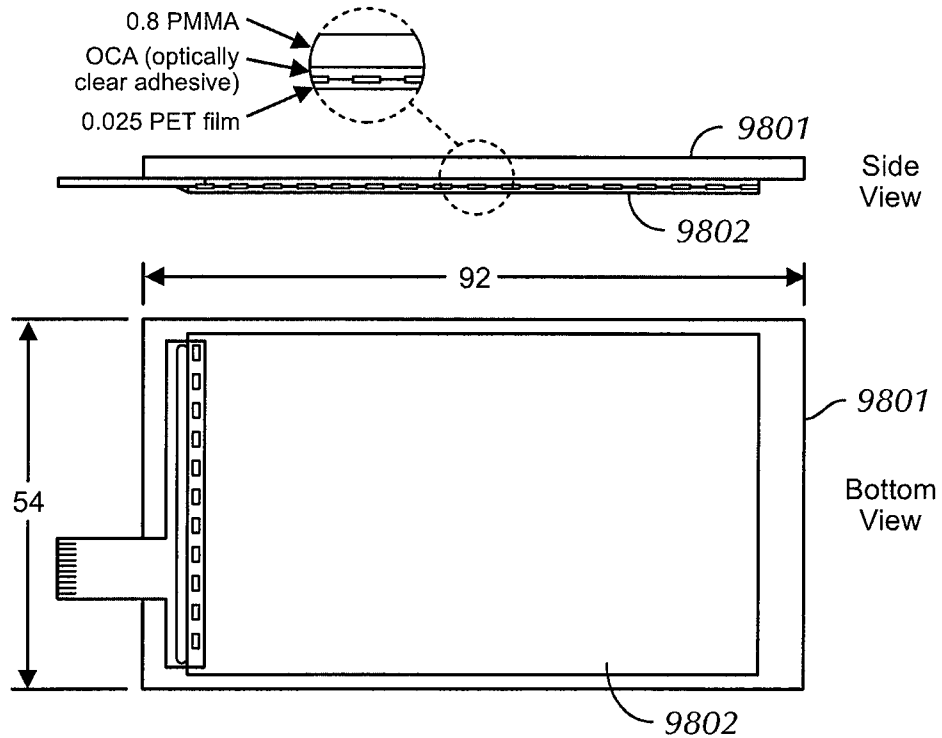

FIG. 98

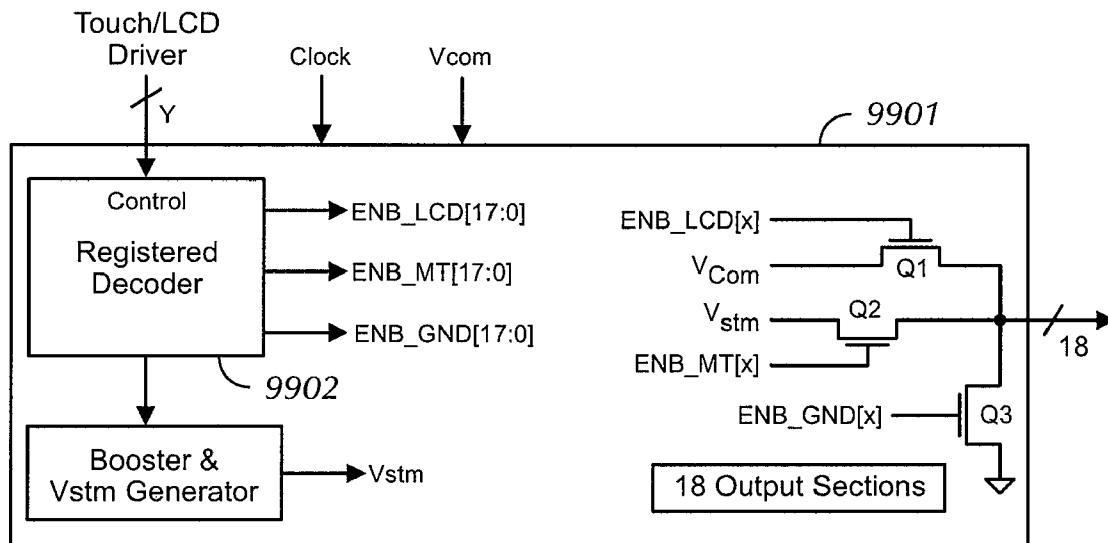

FIG. 99

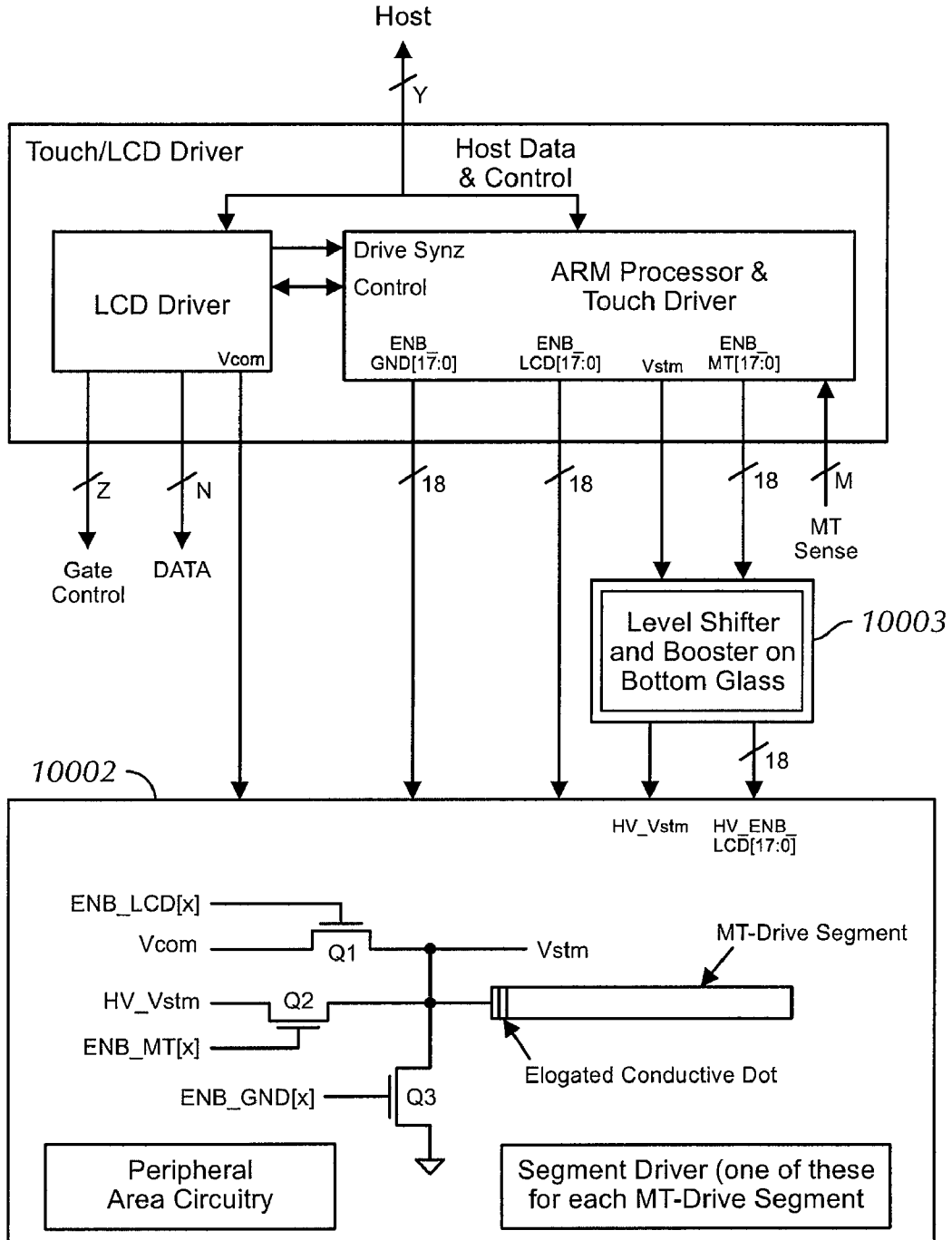

FIG. 100

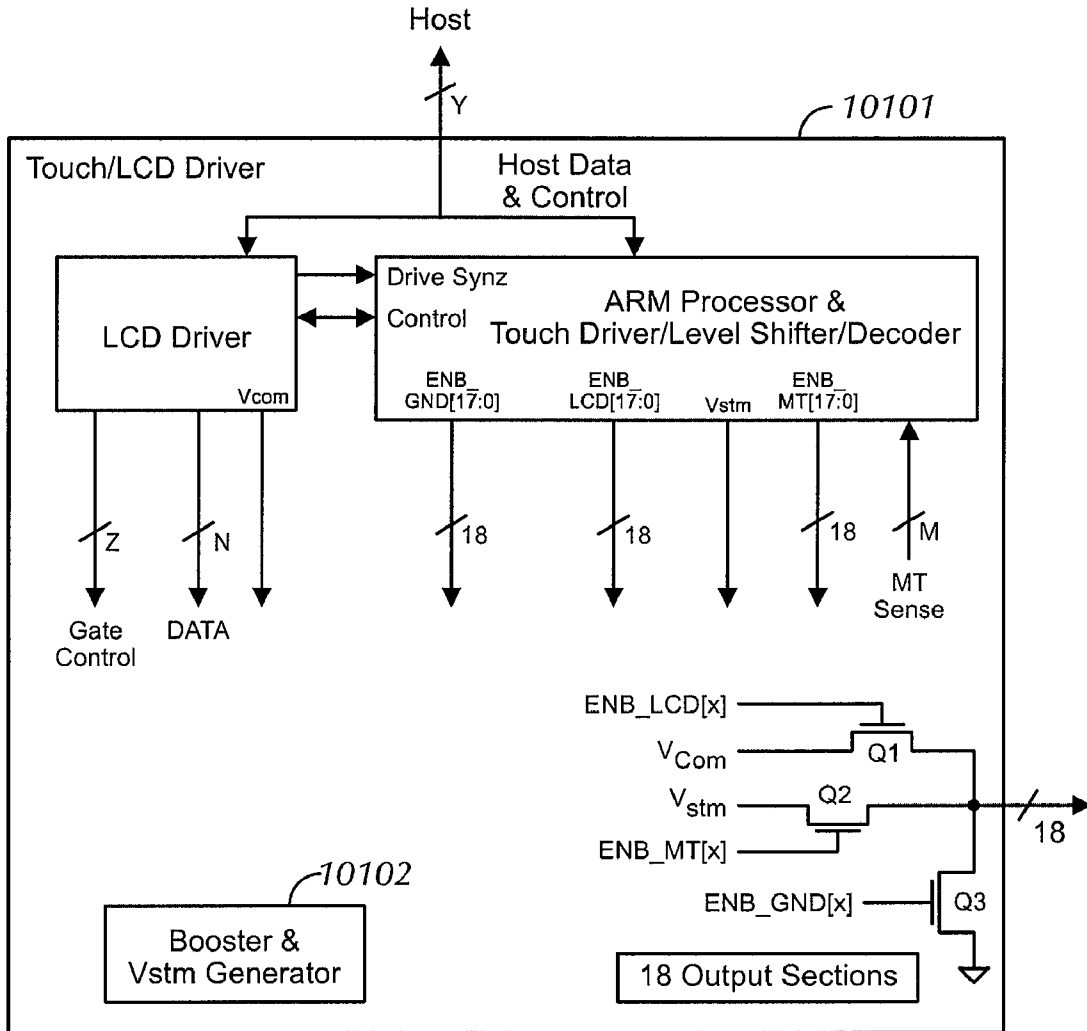

FIG. 101

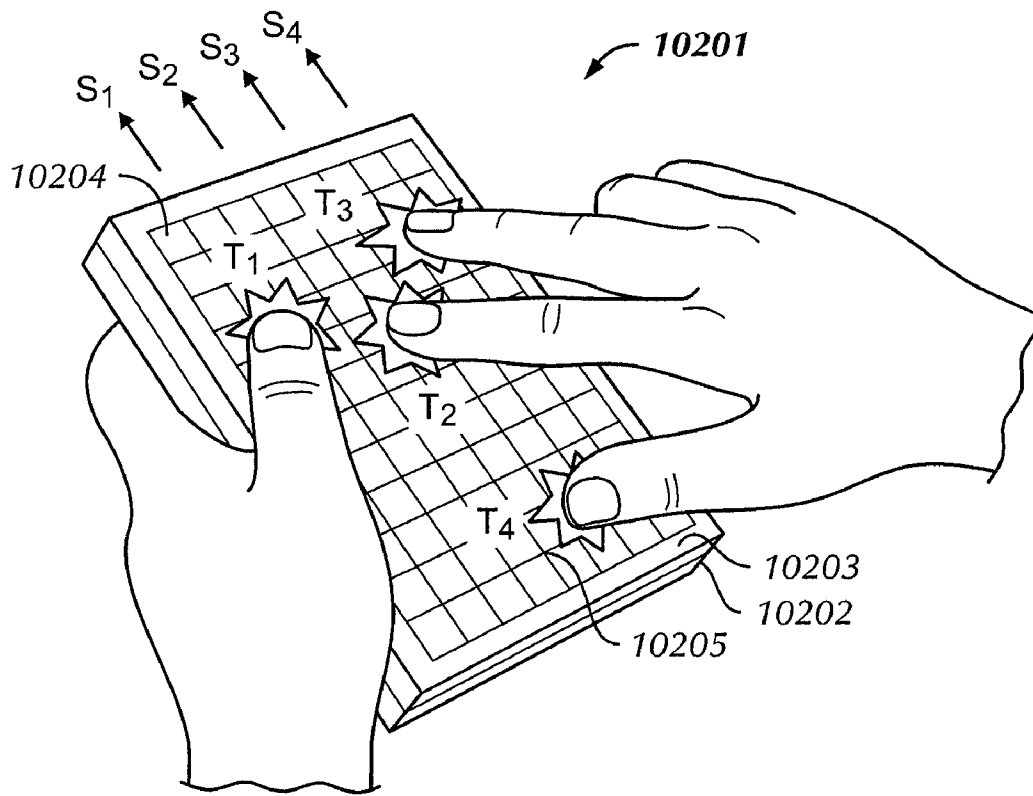

FIG. 102

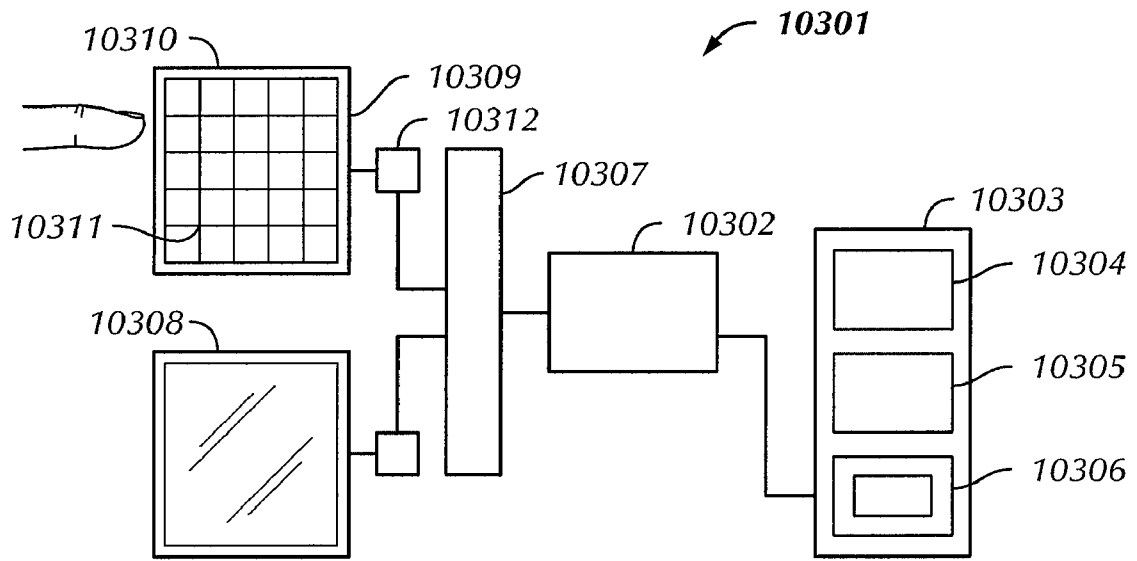

FIG. 103

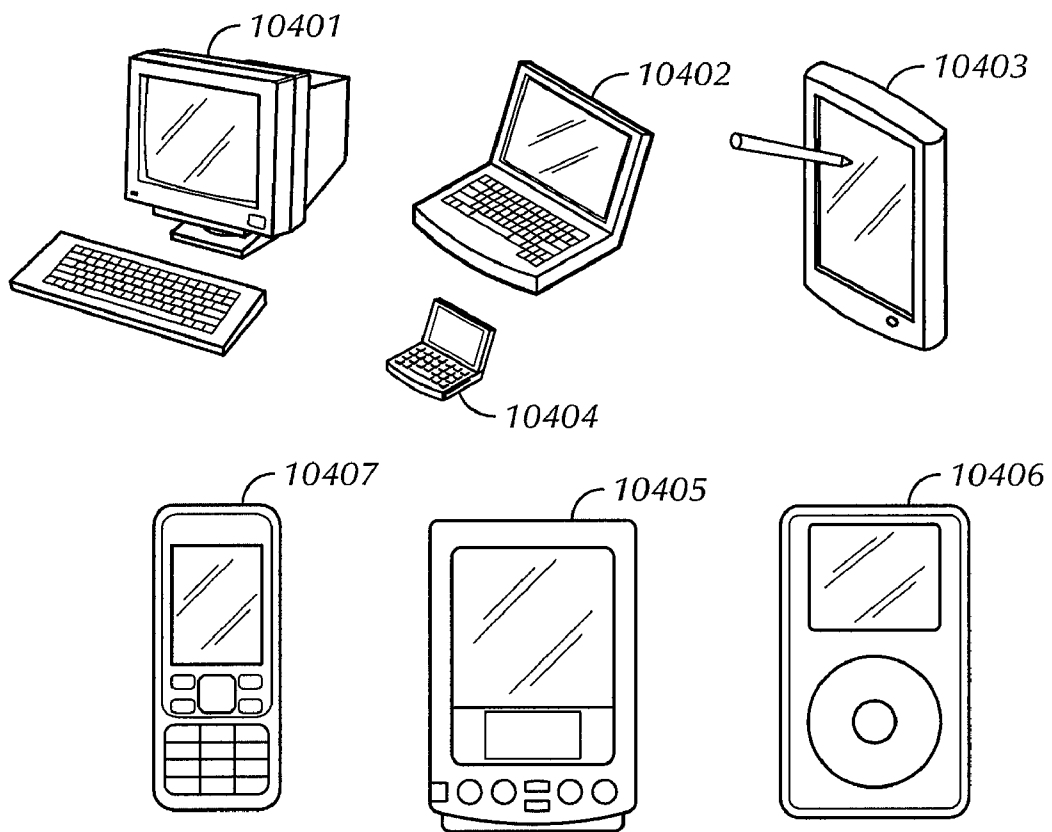

FIG. 104

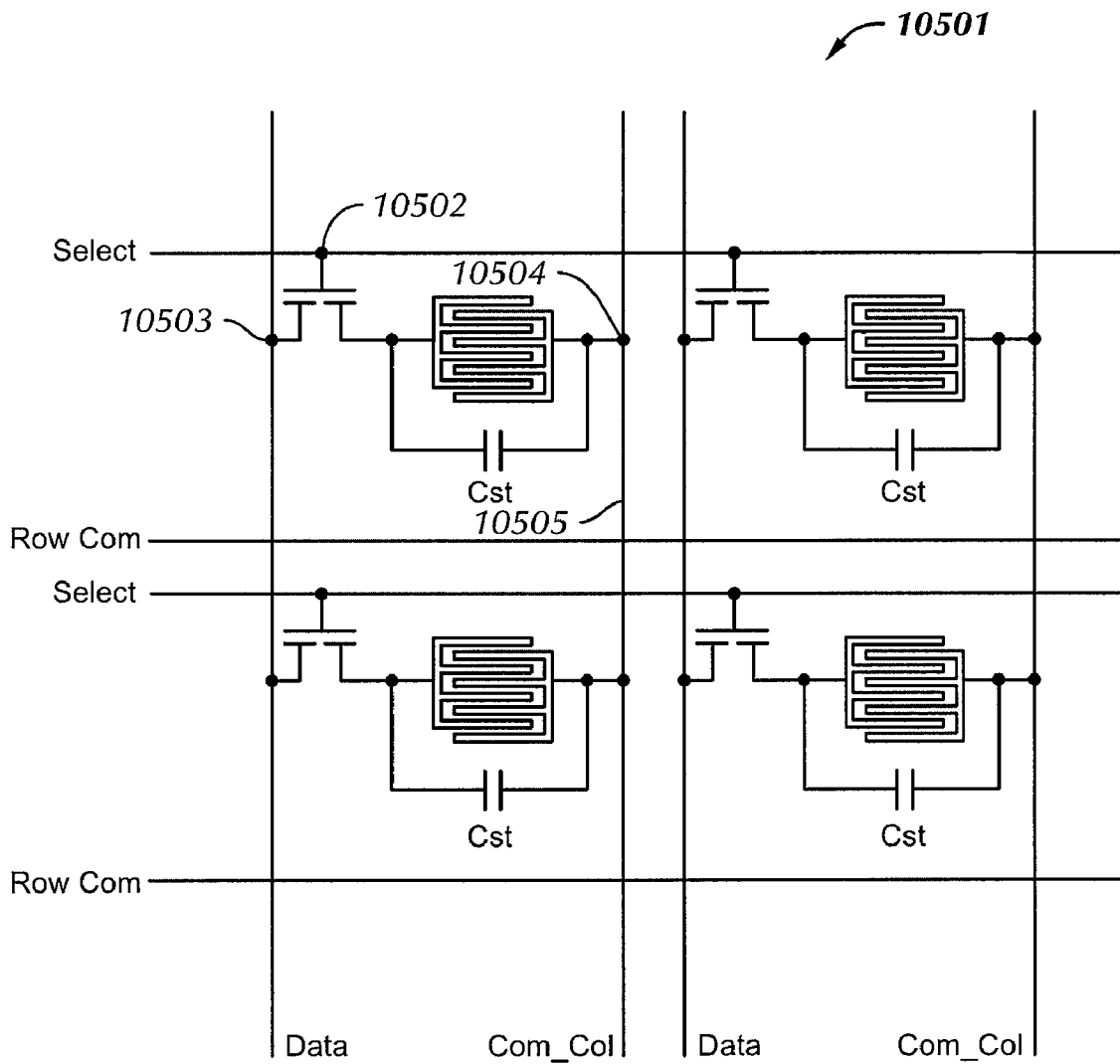

FIG. 105

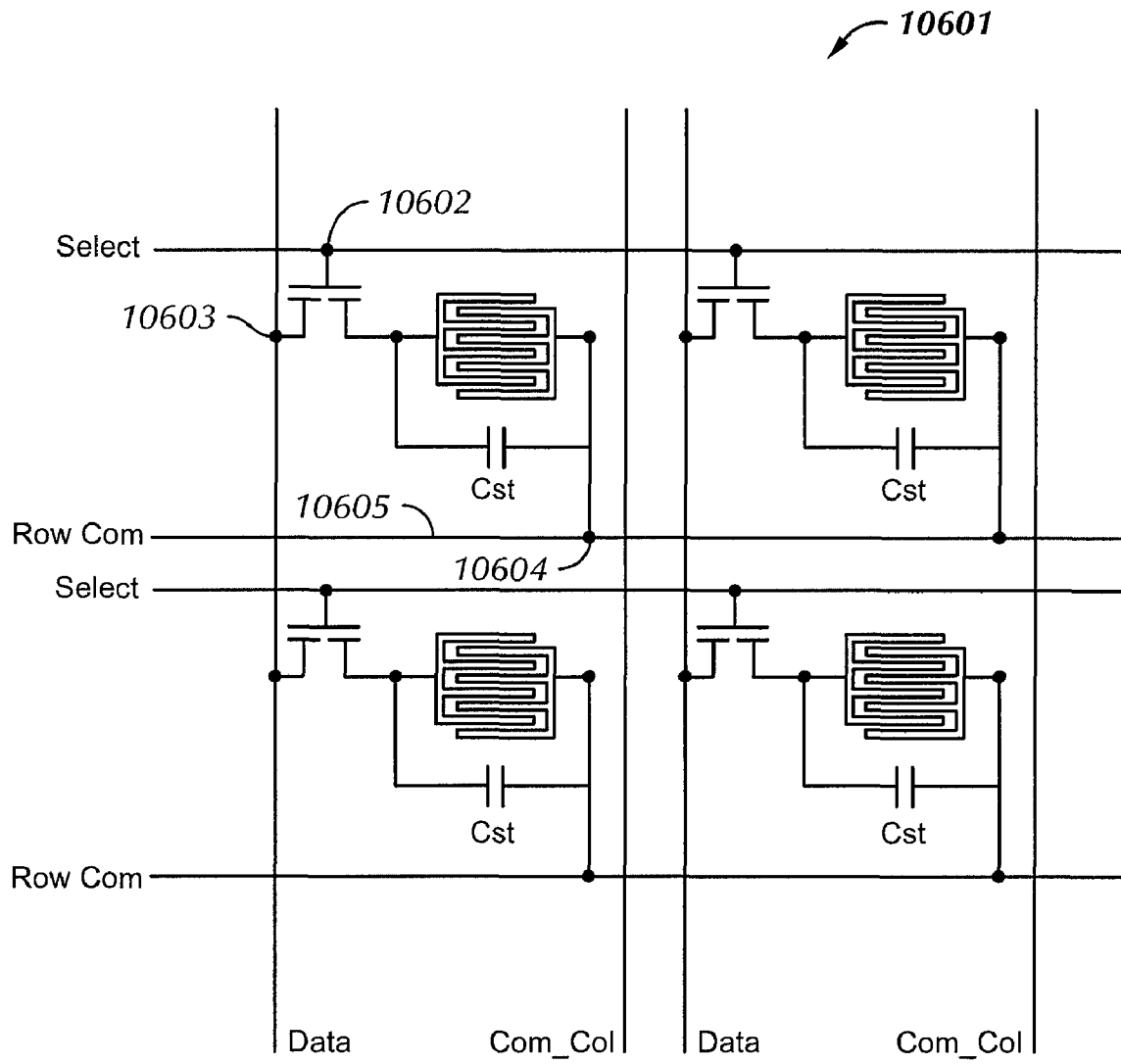

FIG. 106

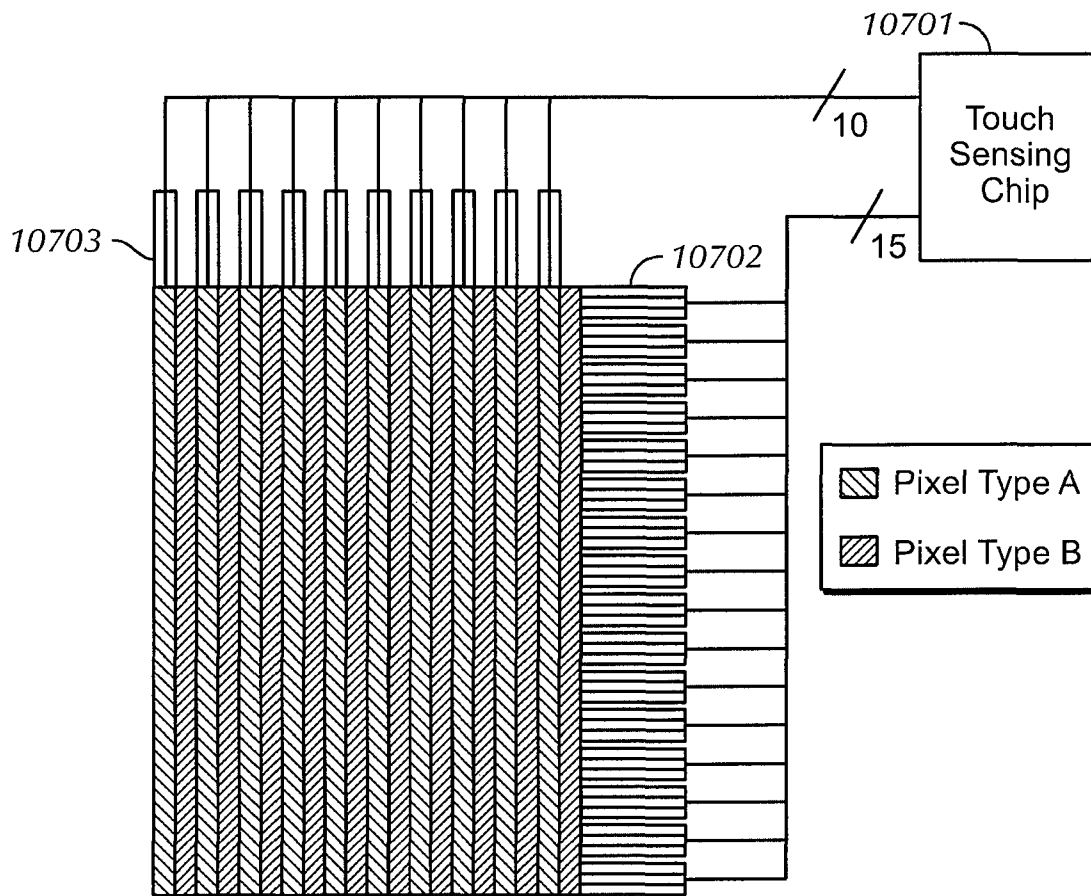

FIG. 107

TOUCH SCREEN LIQUID CRYSTAL DISPLAY

CROSS-REFERENCE TO RELATED APPLICATIONS

This application claims priority to Provisional U.S. Patent Application Ser. No. 60/804,361, filed Jun. 9, 2006, and Provisional U.S. Patent Application Ser. No. 60/883,979, filed Jan. 8, 2007 which are both hereby incorporated by reference in their entirety.

This application is related to the following publications, incorporated by reference herein:

U.S. Patent Publication No.: 2006/0197753, titled "Multi-Functional Hand-Held Device," published Sep. 7, 2006.

U.S. Patent Publication No.: 2006/0097991, titled "Multi-point Touch Screen," published May 11, 2006, and issued as U.S. Pat. No. 7,663,607, issued on Feb. 16, 2010.

U.S. Patent Publication No.: 2007/0257890, titled "Multi-point Touch Screen Controller," published on Nov. 8, 2007;

U.S. Patent Publication No.: 2008/0158181, entitled "Double-Sided Touch Sensitive Panel and Flex Circuit Bonding," published Jul. 3, 2008 and issued as U.S. Pat. No. 8,026,903, issued on Sep. 27, 2011.

U.S. Patent Publication No.: 2008/0062139, entitled "Touch Screen Liquid Crystal Display," published Mar. 13, 2008.

U.S. Patent Publication No.: 2008/0062148, entitled "Touch Screen Liquid Crystal Display," published Mar. 13, 2008.

U.S. Patent Publication No. 2008/0062140, entitled "Touch Screen Liquid Crystal Display," published Mar. 13, 2001.

BACKGROUND

There exist today many types of hand-held electronic devices, each of which utilizes some sort of user interface. The user interface can include an output device in the form of a display, such as a Liquid Crystal Display (LCD), and one or more input devices, which can be mechanically actuated (e.g., switches, buttons, keys, dials, joysticks, joy pads) or electrically activated (e.g., touch pads or touch screens). The display can be configured to present visual information such as text, multi-media data, and graphics, and the input devices can be configured to perform operations such as issuing commands, making selections, or moving a cursor or selector in the electronic device.

Recently work has been progressing on integrating various devices into a single hand-held device. This has further led to attempts to integrate many user interface models and devices into a single unit. A touch screen can be used in such systems for both practical and aesthetic reasons. Additionally, multi-touch capable touch screens can provide a variety of advantages for such a device.

Heretofore, it has been assumed that touch screens, whether single touch or multi-touch, could be produced by fabricating a traditional LCD screen, and disposing a substantially transparent touch sensing device in front of this screen. However, this presents a number of disadvantages, including substantial manufacturing costs.

SUMMARY

According to one embodiment of the invention, an integrated liquid crystal display touch screen is provided. The

touch screen can include a plurality of layers including a first polarizer, a first substrate having display control circuitry formed thereon (e.g., a TFT plate or array plate), a second substrate (e.g., a color filter plate) adjacent to the first, and a second polarizer. The touch screen can further include at least one touch sensing element disposed between the first polarizer and the second polarizer and not between the substrates. The touch sensing element can include one or more touch sensors formed on the second substrate.

The touch sensors can include, a first plurality of touch electrodes formed on the second substrate, a dielectric deposited over the first plurality of electrodes, and a second plurality of touch electrodes formed on top of the dielectric. The touch and drive electrodes can be formed from patterned indium-tin oxide (ITO). The touch sensors can also comprise active circuitry, including, for example, thin film transistors (TFTs). The substrates may be either glass or plastic. The touch electrodes may be part of a mutual capacitance or a self-capacitance arrangement.

In another embodiment, an electronic device incorporating an integrated LCD touch screen is provided. The electronic device can take the form of a desktop computer, a tablet computer, and a notebook computer. The electronic device can also take the form of a handheld computer, a personal digital assistant, a media player, and a mobile telephone. In some embodiments, a device may include one or more of the foregoing, e.g., a mobile telephone and media player.

BRIEF DESCRIPTION OF THE FIGURES

The invention may best be understood by reference to the following description taken in conjunction with the accompanying drawings in which:

FIG. 1 illustrates a multipoint sensing arrangement.

FIG. 2 illustrates a number of contact patches on a multipoint sensing system.

FIG. 3 illustrates a simplified schematic diagram of a mutual capacitance circuit.

FIG. 4 illustrates a process for operating a multipoint sensing arrangement.

FIG. 5 illustrates a representative layout for an LTPS transmissive subpixel.

FIG. 6 illustrates a simplified model of an LTPS as viewed from the top and side.

FIG. 7 illustrates a circuit diagram for a subpixel and shows on which glass substrate the components are fabricated.

FIG. 8 illustrates a basic process flow for manufacturing LCDs.

FIG. 9 illustrates a finished small size LCD module.

FIG. 10 illustrates a block diagram of a touch screen LCD with separate touch driver and LCD driver chips.

FIG. 11 illustrates a block diagram of a touch screen LCD with an integrated LCD and touch driver chip.

FIG. 12 illustrates a basic stackup of a touch screen LCD.

FIG. 13 illustrates an alternative embodiment of a touch screen LCD.

FIG. 14 illustrates an electrode pattern.

FIG. 15 illustrates a stackup diagram embodiment of a touch-screen LCD.

FIG. 16 illustrates a touch pixel circuit for the touch-screen LCD illustrated in FIG. 15.

FIG. 17 illustrates a touch-sensing layer protected by a plastic cover.

FIG. 18 illustrates an output column and a linked set of output gates for a region of a touch-screen.

FIG. 19 illustrates a layout of a touch pixel for a touch-screen LCD.

FIG. 20 illustrates a stackup diagram for one embodiment of a touch screen LCD.

FIG. 21 illustrates a touch sensor array.

FIG. 22 illustrates a physical implementation for Concepts A and B, with top and side views of cabling and subsystem placement.

FIG. 23 illustrates a high-level block diagram showing one possible architecture of bottom glass components.

FIG. 24 illustrates elongated conductive dots.

FIG. 25 illustrates a high-level block diagram for a Touch/LCD Driver integrated circuit.

FIG. 26 illustrates a flexible printed circuit for use with various LCD embodiments described herein

FIG. 27 illustrates a process for simultaneous display updating and touch scanning.

FIG. 28 illustrates an Open Circuit V_{CST} touch drive option.

FIG. 29 illustrates a Drive- V_{CST} touch drive option.

FIG. 30 illustrates an electrical model for the situation where touch drive is used for both touch sensing and LCD V_{COM} modulation.

FIG. 31 illustrates connecting V_{STM} to Cst lines on both sides through conductive dots.

FIG. 32 illustrates a manufacturing process flow for a touch screen LCD.

FIG. 33 illustrates using one-line inversion of V_{COM} as a touch stimulus signal.

FIG. 34 illustrates a stackup diagram for an alternative embodiment of a touch screen LCD.

FIG. 35 illustrates a manufacturing process flow for a touch screen LCD.

FIG. 36 illustrates an embodiment substituting a conductive black matrix for a touch drive layer.

FIG. 37 illustrates a circuit diagram for an embodiment of a touch screen LCD.

FIG. 38 illustrates a stackup diagram for a touch screen LCD.

FIG. 39 illustrates a row-by-row update of display pixels for a touch screen LCD.

FIG. 40 illustrates a touch sensing process for a set of touch-sensitive display rows in a touch screen LCD.

FIG. 41 illustrates a process of detecting touches for three pixels located in different regions of a touch screen LCD.

FIG. 42 illustrates a circuit diagram of another embodiment of a touch screen LCD.

FIG. 43 illustrates a stack up diagram of the embodiment illustrated in FIG. 42.

FIG. 44 illustrates an embodiment substituting a conductive black matrix for a touch sense layer.

FIG. 45 illustrates a stackup diagram of another embodiment of a touch screen LCD.

FIG. 46 illustrates a top view of the embodiment illustrated in FIG. 55.

FIG. 47 illustrates another embodiment of a touch screen LCD.

FIG. 48 illustrates an equivalent circuit of the embodiment of FIG. 47.

FIG. 49 illustrates the waveforms that can be used for touch sensing in the embodiment of FIGS. 47-48.

FIG. 50 illustrates further aspects of touch screen integration for the embodiment of FIG. 47.

FIG. 51 illustrates another embodiment of a touch screen LCD.

FIG. 52 illustrates the waveforms that can be used for touch sensing in the embodiment of FIGS. 51 and 53.

FIG. 53 illustrates an equivalent circuit of the embodiment of FIG. 51.

FIG. 54 illustrates further aspects of touch screen integration for the embodiment of FIG. 51.

FIG. 55 illustrates a stackup diagram for a touch-screen LCD.

FIG. 56 illustrates a process of updating a touch-screen LCD.

FIG. 57 illustrates a stackup diagram for an embodiment of a touch-screen LCD.

FIG. 58 illustrates a stackup diagram for an embodiment of a touch-screen LCD.

FIG. 59 illustrates an exemplary LCD display divided into three regions that can be updated or touch-scanned independently.

FIG. 60 illustrates update and touch-scanning of a touch-screen LCD with three regions.

FIG. 61 illustrates an electrode layout for a touch-screen LCD.

FIG. 62 illustrates circuit components for a touch-screen LCD.

FIG. 63 illustrates a snapshot of an update arrangement for a touch-screen LCD.

FIG. 64 illustrates how metal lines and gaps in ITO that can be fully or partially hidden behind a black matrix.

FIG. 65 illustrates a stackup diagram for a touch-screen LCD.

FIG. 66 illustrates a touch-screen LCD segmented into three regions.

FIG. 67 illustrates a process of performing display updates and touch-scanning in a touch-screen LCD.

FIG. 68 illustrates wiring and ITO layout to segment a touch screen LCD into three regions.

FIG. 69 illustrates a top view and cross-section of a region of a touch-screen LCD that includes guard traces.

FIG. 70 illustrates a top view and cross-section of a region of a touch-screen LCD that does not include guard traces.

FIG. 71 illustrates a region of an exemplary display that contains six touch pixels and their signal wiring.

FIG. 72 illustrates a stackup diagram for another embodiment of a touch-screen LCD.

FIG. 73 illustrates a stackup diagram for another embodiment of a touch-screen LCD.

FIG. 74 illustrates a circuit diagram highlighting V_{COM} signal coupling for a touch screen LCD.

FIG. 75 illustrates an exemplary display.

FIG. 76 illustrates a possible scan pattern for a touch-screen LCD.

FIG. 77 illustrates a circuit diagram for the embodiment of FIG. 79.

FIG. 78 illustrates segment ITO layers.

FIG. 79 illustrates a stackup diagram for another embodiment of a touch-screen LCD.

FIG. 80 illustrates a combined wiring and stackup diagram for the embodiment of FIG. 79.

FIG. 81 illustrates a physical realization of the embodiment of FIG. 79.

FIG. 82 illustrates in-plane switching LCD cells.

FIG. 83 illustrates an organization of electrodes for in-plane switching LCD cells.

FIG. 84 illustrates a circuit diagram for an embodiment of an IPS-based touch-screen LCD.

FIG. 85 illustrates a stackup diagram corresponding to FIG. 84.

FIG. 86 illustrates a stackup diagram for another embodiment of an IPS-based touch-screen LCD.

FIG. 87 illustrates a physical model for Concept F, an embodiment of an IPS-based touch-screen LCD.

FIG. 88 illustrates a stackup diagram corresponding to the embodiment of FIG. 87.

FIG. 89 illustrates a side view of an all glass touch screen LCD.

FIG. 90 illustrates a side view of a touch screen LCD including a plastic layer.

FIG. 91 illustrates a touch screen having multiple plastic layers.

FIG. 92 illustrates a touch screen having a PET layer patterned on two sides with a connection through the PET layer.

FIG. 93 illustrates a combination PET/glass touch screen.

FIG. 94 illustrates a touch screen LCD device assembly.

FIG. 95 illustrates a touch screen LCD having a touch layer patterned on the inside of a transparent plastic housing.

FIG. 96 illustrates a patterned PET substrate that may be used with a touch screen LCD.

FIG. 97 illustrates flexible printed circuits bonded to the PET substrate of FIG. 96.

FIG. 98 illustrates a cover affixed to the assembly of FIG. 97.

FIG. 99 illustrates a simplified diagram of a level shifter/decoder chip on glass.

FIG. 100 illustrates a modified Touch/LCD Driver and peripheral transistor circuit.

FIG. 101 illustrates a simplified block diagram of a fully-integrated Touch/LCD Driver.

FIG. 102 illustrates an application of a touch screen LCD.

FIG. 103 illustrates a block diagram of a computer system incorporating a touch screen.

FIG. 104 illustrates a variety of electronic device and computer system form factors that may be used with a touch-screen LCD according to the present invention.

FIG. 105 illustrates a plurality of IPS LCD sub-pixels connected to form a plurality of touch sense columns.

FIG. 106 illustrates a plurality of IPS LCD sub-pixels connected to form a plurality of touch sense rows.

FIG. 107 illustrates an IPS LCD with integrated touch sensing.

DETAILED DESCRIPTION

The following description is presented to enable any person skilled in the art to make and use the invention, and is provided in the context of a particular application and its requirements. Various modifications to the disclosed embodiments will be readily apparent to those skilled in the art, and the general principles defined herein may be applied to other embodiments and applications without departing from the spirit and scope of the present invention. Thus, the present invention is not limited to the embodiments shown, but is to be accorded the widest scope consistent with the claims.

1. LCD and Touch Sensing Background

Disclosed herein are techniques to integrate touch sensing technology into liquid crystal displays.

As known to those skilled in the art, an LCD includes a plurality of layers, most basically, a top glass, a liquid crystal, and a bottom glass. The top and bottom glass can be patterned to provide the boundaries of the cells that contain the liquid crystal for a particular display pixel. The top and bottom glass can also be patterned with various layers of conducting materials and thin film transistors that allow the voltage across the liquid crystal cells to be varied to manipulate the orientation of the liquid crystal, thereby controlling the color and brightness of the pixel.

As described in the applications incorporated by reference, a touch surface, and specifically, a multi-touch capable transparent touch surface can be formed from a series of layers.

The series of layers can include at least one substrate, e.g., glass, which can have disposed thereon a plurality of touch sensitive electrodes. For example, a mutual capacitance arrangement can include a plurality of drive electrodes and a plurality of sense electrodes separated by a non-conducting layer, i.e., the glass. Capacitive coupling between the drive and sense electrodes can be affected by proximity of a conductive object (e.g., a user's finger). This change in capacitive coupling can be used to determine the location, shape, size, motion, identity, etc. of a particular touch. These parameters can then be interpreted to control operation of a computer or other electronic device. Self-capacitance arrangements, as described below, are also known to those skilled in the art.

By integrating the layered structure of an LCD and a touch sensor, a variety of benefits can be achieved. This integration can include combining or interleaving the layered structures described above. Integration can further include eliminating redundant structures and/or finding dual purposes (e.g., one purpose for the touch function and another for the display function) for particular layers or structures. This can permit some layers to be eliminated, which can reduce cost and thickness of the touch screen LCD, as well as simplify manufacturing. A variety of different arrangements are possible, some of which are discussed in greater detail herein.

Specifically, various embodiments of an integrated touch screen LCD are discussed below. However, those skilled in the art will appreciate that the detailed description given herein with respect to these figures is exemplary and not exhaustive and that many variations on these embodiments are possible. Additionally, although many of the disclosed embodiments relate to multi-touch capable arrangements, many of the teachings can be applied to single-touch displays as well.

1.1. Multi-Touch Sensing

Recognizing multiple simultaneous or near-simultaneous touch events may be accomplished with a multi-touch sensing arrangement as illustrated in FIG. 1. Multi-touch sensing arrangement 100 can detect and monitor multiple touch attributes (including, for example, identification, position, velocity, size, shape, and magnitude) across touch sensitive surface 101, at the same time, nearly the same time, at different times, or over a period of time. Touch-sensitive surface 101 can provide a plurality of sensor points, coordinates, or nodes 102 that function substantially independently of one another and that represent different points on a touch sensitive surface. Sensing points 102 may be positioned in a grid or a pixel array, with each sensing point capable of generating a signal at the same time. Sensing points 102 may be considered as mapping touch sensitive surface 101 into a coordinate system, for example, a Cartesian or polar coordinate system.

A touch-sensitive surface may, for example, be in the form of a tablet or a touch screen. To produce a touch screen, the capacitance sensing points and other associated electrical structures can be formed with a substantially transparent conductive medium, such as indium tin oxide (ITO). The number and configuration of sensing points 102 may be varied. The number of sensing points 102 generally depends on the desired resolution and sensitivity. In touch-screen applications, the number of sensing points 102 may also depend on the desired transparency of the touch screen.

Using a multi-touch sensing arrangement, like that described in greater detail below, signals generated at nodes 102 of multi-touch sensor 101 may be used to produce an image of the touches at a particular point in time. For example, each object (e.g., finger, stylus, etc.) in contact with or in proximity to touch-sensitive surface 101 can produce contact patch area 201, as illustrated in FIG. 2. Each contact

patch area **201** may cover several nodes **102**. Covered nodes **202** may detect the object, while remaining nodes **102** do not. As a result, a pixilated image of the touch surface plane (which may be referred to as a touch image, a multi-touch image, or a proximity image) can be formed. The signals for each contact patch area **201** may be grouped together. Each contact patch area **201** may include high and low points based on the amount of touch at each point. The shape of contact patch area **201**, as well as the high and low points within the image, may be used to differentiate contact patch areas **201** that are in close proximity to one another. Furthermore, the current image can be compared to previous images to determine how the objects may be moving over time, and what corresponding action should be performed in a host device as a result thereof.

Many different sensing technologies can be used in conjunction with these sensing arrangements, including resistive, capacitive, optical, etc. In capacitance-based sensing arrangements, as an object approaches touch-sensitive surface **101**, a small capacitance forms between the object and sensing points **102** in proximity to the object. By detecting changes in capacitance at each of the sensing points **102** caused by this small capacitance, and by noting the position of the sensing points, a sensing circuit **103** can detect and monitor multiple touches. The capacitive sensing nodes may be based on self-capacitance or mutual-capacitance.

In self-capacitance systems, the “self” capacitance of a sensing point is measured relative to some reference, e.g., ground. Sensing points **102** may be spatially separated electrodes. These electrodes can be coupled to driving circuitry **104** and sensing circuitry **103** by conductive traces **105a** (drive lines) and **105b** (sense lines). In some self-capacitance embodiments, a single conductive trace to each electrode may be used as both a drive and sense line.

In mutual capacitance systems, the “mutual” capacitance between a first electrode and a second electrode can be measured. In mutual capacitance sensing arrangements, the sensing points may be formed by the crossings of patterned conductors forming spatially separated lines. For example, driving lines **105a** may be formed on a first layer and sensing lines **105b** may be formed on a second layer **105b** such that the drive and sense lines cross or “intersect” one another at sensing points **102**. The different layers may be different substrates, different sides of the same substrate, or the same side of a substrate with some dielectric separation. Because of separation between the drive and sense lines, there can be a capacitive coupling node at each “intersection.”

The arrangement of drive and sense lines can vary. For example, in a Cartesian coordinate system (as illustrated), the drive lines may be formed as horizontal rows, while the sense lines may be formed as vertical columns (or vice versa), thus forming a plurality of nodes that may be considered as having distinct x and y coordinates. Alternatively, in a polar coordinate system, the sense lines may be a plurality of concentric circles with the drive lines being radially extending lines (or vice versa), thus forming a plurality of nodes that may be considered as having distinct radius and angle coordinates. In either case, drive lines **105a** may be connected to drive circuit **104**, and sensing lines **105b** may be connected to sensing circuit **103**.

During operation, a drive signal (e.g., a periodic voltage) can be applied to each drive line **105a**. When driven, the charge impressed on drive line **105a** can capacitively couple to the intersecting sense lines **105b** through nodes **102**. This can cause a detectable, measurable current and/or voltage in sense lines **105b**. The relationship between the drive signal and the signal appearing on sense lines **105b** can be a function

of the capacitance coupling the drive and sense lines, which, as noted above, may be affected by an object in proximity to node **102**. Capacitance sensing circuit (or circuits) **103** may sense sensing lines **105b** and may determine the capacitance at each node as described in greater detail below.

As discussed above, drive lines **105a** can be driven one at a time, while the other drive lines are grounded. This process can be repeated for each drive line **105a** until all the drive lines have been driven, and a touch image (based on capacitance) can be built from the sensed results. Once all the lines **105a** have been driven, the sequence can repeat to build a series of touch images. However, in some embodiments of the present invention, multiple drive lines may be driven substantially simultaneously or nearly simultaneously, as described in U.S. patent application Ser. No. 11/619,466, titled “Simultaneous Sensing Arrangement,” filed Jan. 3, 2007.

FIG. 3 illustrates a simplified schematic diagram of mutual capacitance circuit **300** corresponding to the arrangement described above. Mutual capacitance circuit **300** may include drive line **105a** and sense line **105b**, which can be spatially separated thereby forming capacitive coupling node **102**. Drive line **105a** may be electrically (i.e., conductively) coupled to drive circuit **104** represented by voltage source **301**. Sense line **105b** may be electrically coupled to capacitive sensing circuit **103**. Both drive line **105a** and sense line **105b** may, in some cases, include some parasitic capacitance **302**.

As noted above, in the absence of a conductive object proximate the intersection of drive line **105a** and sense line **105b**, the capacitive coupling at node **102** can stay fairly constant. However, if an electrically conductive object (e.g., a user’s finger, stylus, etc.) comes in proximity to node **102**, the capacitive coupling (i.e., the capacitance of the local system) changes. The change in capacitive coupling changes the current (and/or voltage) carried by sense line **105b**. Capacitance sensing circuit **103** may note the capacitance change and the position of node **102** and report this information in some form to processor **106** (FIG. 1).

With reference to FIG. 1, sensing circuit **103** may acquire data from touch surface **101** and supply the acquired data to processor **106**. In some embodiments, sensing circuit **103** may be configured to send raw data (e.g., an array of capacitance values corresponding to each sense point **102**) to processor **106**. In other embodiments, sensing circuit **103** may be configured to process the raw data itself and deliver processed touch data to processor **106**. In either case, the processor may then use the data it receives to control operation of computer system **107** and/or one or more applications running thereon. Various implementations along these lines are described in the applications referenced above, and include a variety of computer systems having touch pads and touch screens.

In some embodiments, sensing circuit **103** may include one or more microcontrollers, each of which may monitor one or more sensing points **102**. The microcontrollers may be application specific integrated circuits (ASICs) that work with firmware to monitor the signals from touch sensitive surface **101**, process the monitored signals, and report this information to processor **106**. The microcontrollers may also be digital signal processors (DSPs). In some embodiments, sensing circuit **103** may include one or more sensor ICs that measure the capacitance in each sensing line **105b** and report measured values to processor **106** or to a host controller (not shown) in computer system **107**. Any number of sensor ICs may be used. For example, a sensor IC may be used for all lines, or multiple sensor ICs may be used for a single line or group of lines.

FIG. 4 illustrates at a high level process **400** for operating a multi-touch sensing arrangement, like that described above.

The process may begin at block 401 where plurality of sensing points 102 can be driven. Following block 401, the process flow can proceed to block 402, where the outputs from sensing points 102 can be read. For example, a capacitance value for each sensing point 102 can be obtained. Following block 402, the process can proceed to block 403 where an image or other form of data (signal or signals) of the touch at one moment in time can be produced and thereafter analyzed to determine where objects touching or in proximity to the touch sensor may be located. Following block 403, the process can proceed to block 404, where the current image or signal may be compared to one or more past images or signals to determine a change in one or more of the shape, size, location, direction, speed, acceleration, pressure, etc. for each object. This information can be subsequently used (in step 405) to perform an action in computer system 107, ranging from moving a pointer or cursor to complex gesture-based interactions.

1.2. Transflective LCDs

To better understand integration of touch-sensing technology with transflective LCDs, a brief introduction to transflective LCDs may be helpful. The following is an overview of a typical subpixel cell found in low temperature poly silicon (LTPS) transflective LCDs.

1.2.1. Circuit Basics

FIG. 5 shows a representative layout for an LTPS transflective subpixel 500. Display information can be transferred to the subpixel's capacitors C_{ST} and C_{LC} (not shown) when a voltage representing the desired grey level is applied to the data bus 501 and the select line 502 is asserted. The select line 502 assertion level can be near the gate drive positive supply voltage. During the time when select line 502 is asserted, the voltage on V_{CST} (and V_{COM} which is not shown) can be constant. All the circuit elements shown in FIG. 5, which includes metal, poly, active, oxide, and ITO, can be fabricated on the LCD's bottom glass.

FIG. 6 shows a simplified model of a low temperature poly-silicon (LTPS) LCD 600, including a top view 601 and a side view 602. Top view 601 shows a see-through view of the V_{CST} routing 603 on the bottom glass 608 in both the display area 604 and the non-display area 605. Side view 602 shows a cross section of the display.

Each display row can include horizontal traces for V_{CST} 606 and select (not shown). The select traces connect to gate drive circuitry made up of poly-silicon thin film transistors (p-Si TFTs), also not shown. The V_{CST} traces 606 can run from display edge to display edge and can connect together, e.g., as shown on the left. The V_{CST} traces can also connect, through a conductive dot 607, to an ITO plane 609 on the top glass 610. Typically, four conductive dots, one in each corner, can be used to connect the V_{COM} plane to V_{COM} Drive 611. FIG. 6 shows only one dot 607 for simplicity. The voltage of V_{CST} and top glass ITO 609 can be set by V_{COM} Drive, which can be provided by the LCD driver IC (not shown). V_{CST} can also be connected to another drive source other than V_{COM} Drive 611.

FIG. 7 illustrates a circuit diagram 700 for a subpixel and shows on which glass substrate various components can be fabricated. The bottom glass 701 can be the substrate for the integration of all the TFT pixel circuitry 703. This can include the select line drivers and control logic. The bottom glass can also serve as the substrate for chip on glass (COG) components, such as the LCD driver (not shown). The upper electrode 704 of capacitor C_{LC} can be on the top glass 702. Electrode 704 can be an ITO plane that covers the entire display area and forms the counter electrode to the bottom electrode 705 making C_{LC} . Upper electrode 704 can also

connect, e.g., through four corner-located conductive dots 706 (only one shown), to V_{COM} Drive 707 on bottom glass 701.

1.2.2. V_{COM}

Minimizing or eliminating the DC component of the voltage across the liquid crystal (LC) can reduce or eliminate some undesirable image artifacts. Therefore, the electric field across the LC can be periodically flipped while maintaining overall balance between the two field directions. Obtaining perfect electric field balance can be difficult, which can lead to small DC offsets that can produce unwanted image artifacts. To mask flicker due to DC offsets one of several inversion schemes known to those skilled in the art, such as dot inversion, can be employed.

1.2.3. Modulating V_{COM}

In some embodiments, it may be desirable to reduce the voltage range of data drivers. Therefore, the V_{COM} ITO plane and the V_{CST} traces can be modulated from ground to the supply rail to produce an AC voltage across the LC. However, this can restrict the available inversion methods to only the frame and line types.

V_{COM} Drive requirements can be fairly simple: its voltage can remain constant until the charge transfer has completed for a row of pixels, thus setting their grey levels. Once the display pixels are set, V_{COM} Drive can change without significantly affecting the LC state provided that parasitic pathways into and out of the subpixel remain small.

1.2.4. Constant V_{COM}

V_{COM} modulation can complicate the integration of touch sensing with LCDs. Various techniques for overcoming these complications are discussed below. An alternative method of minimizing the DC component of the voltage across the liquid crystal can be employed. One such alternative method is disclosed in J. Hector and P. Buchschacher, "Low Power Driving Options for an AMLCD Mobile Display Chipset", SID 02 Digest, pp. 695-697, which is incorporated by reference herein. This alternative method can allow V_{COM} to remain at a constant voltage, does not require large-voltage range data drivers, and can consume low power. Various advantages of using a constant V_{COM} are described below.

1.3. LCD Manufacturing

The manufacturing of LCD panels can be done using a batch process on large pieces of glass called mother-glass. Two pieces of mother-glass can be used: a top mother-glass, which can provide the substrate for the color filter, black matrix, and the upper electrode for C_{LC} ; and a bottom mother-glass, which can provide the substrate for the active matrix TFT array and drive circuitry.

A basic process flow 800 for manufacturing LCDs is shown in FIG. 8. Two large sheets of mother-glass, one for the top portion of the LCD and one for the bottom portion, can go through separate processing steps 801 and 802 before being aligned (block 803), pressed together, and heated (block 804) to cure seals between the top and bottom glass thereby producing a stable panel structure. The large panel can then be scribed and broken into smaller modules of the desired dimensions (block 805). The individual modules can have their edges ground (block 806) before being filled with liquid crystals (block 807). After filling, the modules can be sealed (block 808). Polarizers and electrical components can be attached (block 809). Flexible printed circuits (FPCs) can be attached to their substrates at or near the end of the process (block 810).

A finished LCD module 900 is shown in FIG. 9. The illustrated LCD module includes a chip on glass (COG) LCD driver 901 attached to the bottom glass 902 and also includes a flex on glass (FOG) flexible printed circuit (FPC) 903

attached to the bottom glass **902**. Both components can be electrically connected to bottom glass pads and held in place using an anisotropic conductive adhesive (ACA). Bottom glass **902** can extend beyond top glass **904** to provide a shelf **905** to mount the COG LCD driver **901**, the FPC **903**, and other supporting components. For handheld devices, the system processor board that manages the data and controls for the LCD can be placed under the backlight **906**.

Additional components used to support touch sensing (e.g., FPCs) can also attach to shelf **905**. Other attachment points are also possible. Details are discussed in conjunction with relevant embodiments described below.

1.4. Combining LCDs and Touch Sensing

The stack up diagrams discussed herein may be better understood in conjunction with the block diagrams of FIGS. **10** and **11**. Starting at the top, touch sense electrodes **1001**, **1101** can be deposited on the top (user side) of LCD top glass **1002**, **1102**. Touch drive electrodes **1003**, **1103** can be patterned on the bottom side of top glass **1002**, **1102**. Conductive dots **1004**, **1104** can connect drive electrodes **1003**, **1103** to driver **1005**, **1105**, which can also be located on bottom glass **1006**, **1106**. A shelf **1007**, **1107** on bottom glass **1006**, **1106** can house LCD driver chip **1008**, **1108** and the touch sensor driver chip **1009**, which can interface with each other (FIG. **10**) or be integrated into a single component (FIG. **11**). Finally, a FPC **1010**, **1110**, also bonded to the shelf can connect host device **1011**, **1111**.

2. Integration Options

Some embodiments of an LCD with integral touch sensing can include a top glass and a bottom glass. Display control circuitry can be formed on one and/or both of these glass layers to affect the amount of light that passes through a layer of liquid crystal between the two glass layers. The space between the external edges of the top and bottom glass is referred to herein as the liquid crystal module (LCM).

A typical LCD stackup **1200** typically includes additional layers, as illustrated in FIG. **12**. In FIG. **12**, a hard-coated PMMA layer **1201** can protect a LCD polarizer **1202** and the top glass **1203**, and a second polarizer **1205** can be included between bottom glass **1204** and a backlight **1206**.

Integrating touch-sensing technology into an LCD can be achieved using a variety of techniques. For instance, different touch-sensing elements and/or layers may be incorporated in a LCD display, with different embodiments varying in factors such as display and/or manufacturing cost, display size, display complexity, display durability, display functionality, and image display quality. In some embodiments, touch-sensing capability can be included into an LCD by integrating touch-sensing elements on the LCD display outside of the LCM. In other embodiments, touch-sensing elements can be added both inside the LCM (e.g., between the two glass layers) as well as outside of the LCM. In still other embodiments, a set of touch-sensing elements can be added only inside the LCM (e.g., between the two glass layers). The following sections describe a number of concepts for each of the above-mentioned embodiments.

2.1. Touch-Sensing Outside of the Liquid Crystal Module

Adding touch-sensing elements outside of the LCM allows touch sensing capabilities to be added to an LCD display with little to no impact on typical LCD manufacturing practices. For instance, a touch sensing system and LCD display system might be fabricated separately and integrated in a final step to form an LCD with touch sensing capabilities. Including the touch-sensing elements outside of the LCM can also allow the touch-sensing elements to be placed close to the area touched by the user, potentially reducing electrical interference between the display and touch components.

The following two embodiments, identified as Concept C and Concept N, can incorporate such external touch-sensing elements.

2.1.1. Concept C

One embodiment of the present invention, Concept C, uses the stackup illustrated in FIG. **13**, which allows the touch function to be separate from the LCD. In Concept C, two additional indium-tin oxide (ITO) layers (ITO1 **1301** and ITO2 **1302**) can be patterned on top of the color filter (CF) plate (e.g., the top glass layer) These layers can be used for touch sense and touch drive elements of a touch sensor, e.g., a mutual-capacitance touch sensor. These ITO layers can be patterned into columns and/or rows (as shown in FIGS. **1** and **2**, and described in the preceding multi-touch sensing description), and can be separated by a dielectric **1305**, such as a glass substrate or a thin (e.g., 5-12 nm) SiO₂ layer.

In some embodiments, the electrode pattern used in the touch elements may be optimized to reduce visual artifacts. For instance, FIG. **14** illustrates a diamond electrode pattern, which can reduce visual artifacts.

In Concept C, the FPCs that carry touch sensing data can attach to the top surface of the top glass **1303**.

2.1.2. Concept N

One embodiment of the present invention, Concept N, can implement capacitive sensing on the outside surface of the color filter (CF) plate using self-capacitance sensing. Concept N can use the stackup illustrated in FIG. **15**, in which the touch sensing components can be located on top of CF plate **1501** (top glass). LCDs based on Concept N can be built without altering standard LCD processing by forming TFTs **1503** with two metal layers and patterned ITO **1500** on CF plate **1501** using, for example, the same LTPS process used for conventional TFT plate **1504**. Touch ITO layer **1500** can be patterned into a plurality of touch pixels **1612** (FIG. **16**). Touch ITO layer **1500** can be protected by a plastic cover **1702** (shown in FIG. **17**) that can also serve as the surface touched by a user.

FIG. **16** illustrates a self-capacitance touch pixel circuit for Concept N. Each ITO touch pixel **1612** can be connected to two TFTs, e.g., an input TFT **1604** and an output TFT **1608**. The input TFT **1604** can charge ITO touch pixel **1612**, while output TFT **1608** can discharge ITO touch pixel **1612**. The amount of charge moved can depend on the ITO touch pixel's **1612** capacitance, which can be altered by the proximity of a finger. Further details of self-capacitance touch-sensing are described above and in U.S. Pat. No. 6,323,846, titled "Method and Apparatus for Integrating Manual Input," issued Nov. 27, 2001, which is hereby incorporated by reference in its entirety.

In one embodiment, an output column **1610** can be shared by touch pixels vertically, and output gates **1606** can be shared by touch pixels horizontally, as shown in FIGS. **16** and **18** for output column **1610** 'C0' and output gates **1606** 'R3'. FIG. **19** shows a detailed layout of a touch pixel.

2.2. Partially-Integrated Touch-Sensing

Integrating touch-sensing elements inside the LCM can provide a variety of advantages. For example, touch-sensing elements added inside the LCM could "reuse" ITO layers or other structures that would otherwise be used only for display functions to also provide touch-sensing functionality. Incorporating touch-sensing features into existing display layers can also reduce the total number of layers, which can reduce the thickness of the display and simplify the manufacturing process.

The following embodiments can include touch-sensing elements inside and outside the LCM. Because integrating touch-sensing elements within the LCM may result in noise

and interference between the two functions, the following designs can also include techniques that allow elements to be shared while reducing or eliminating any negative effects on the display and/or touch-sensing outputs caused by electrical interference between the two.

2.2.1. Concept A

Concept A can use the basic stackup **2000** illustrated in FIG. **20**, with a multi-touch capable (“MT”) ITO sense layer (ITO1) **2001** positioned on the user side of top glass **2002**, between top glass and polarizer **2003**. Starting from the top, the touch sensing layers can include: ITO1 **2001** (an ITO layer that can be patterned into N sense (or drive) lines) and ITO2 **2004** (an ITO layer that can be patterned into M drive (or sense) lines). ITO2 layer **2004** can also serve as the V_{COM} electrode for the LCD.

2.2.1.1. Concept A: Touch Sensor Electrodes

The touch sensor electrode array can include two layers of patterned ITO as illustrated in FIG. **21** (left side). FIG. **21** is a simplified view of one possible implementation of touch sensor electrodes. The layer closer to the viewer, ITO1 **2101**, can be the touch output layer also called the sense layer or the sense lines. The touch drive layer **2102** can be located on layer ITO2. ITO2 can also form the upper electrode of the capacitor C_{LC} (see FIG. **7**). FIG. **21** (right side) also shows a detail of three sense pixels **2103a**, **2103b**, and **2103c** along with associated capacitors. Both the sense and drive lines can have a 5 mm pitch with a 10 to 30 micron gap. The gap can be just small enough to be invisible to the naked eye, but still large enough to be easy to etch with a simple proximity mask. (Gaps in the figure are greatly exaggerated).

FIG. **22** shows one possible physical implementation for Concept A, with top view **2201** and side view **2202** of cabling and subsystem placement. Top view **2201** shows the approximate positions of FPC **2203** (discussed in greater detail below) in an unfolded state. FIG. **22** represents just one physical implementation where a discrete touch level shifter/decoder COG can be used. Alternative architectures that minimize the number of discrete touch components are discussed below. For mechanical stability, the FPC can be bent, as shown in side view **2202**, so that stress on the T-tab **2204** and B-tab **2205** bonds are minimized. FIG. **23** is a high-level block diagram showing one possible architecture **2300** of the main bottom glass components, and the segmented ITO2 layer **2301** on the top glass used for touch sensing. The segments **2302** of ITO2 on the top glass each connect through a conductive dot **2303** to a corresponding pad on the bottom glass. The pads on the bottom glass can each connect to the touch driver, discussed below.

2.2.1.2. Concept A: Conductive Dots

Conductive dots located in the corners of the LCD can be used to connect the V_{COM} electrode to drive circuits. Additional conductive dots can be used to connect the touch drive lines to touch-drive circuitry. The dots can have sufficiently low resistance so as to not add significantly to the phase delay of the touch drive signals (discussed in greater detail below). This can include limiting the resistance of a conductive dot to 10 ohms or less. The size of the conductive dot can also be limited to reduce the real estate needed.

As shown in FIG. **24**, elongated conductive dots **2401** can be used to reduce both dot resistance and real estate requirements. Touch drive segments **2402** can be about 5 mm wide, which can provide a large area to reduce dot resistance.

2.2.1.3. Concept A: Flex Circuit and Touch/LCD Driver IC

A conventional display (e.g., FIG. **9**) can have an LCD Driver integrated circuit (IC) **901**, that can control low-level operation of the display. A system host processor can exercise high-level control over the display by sending commands and

display data to LCD Driver **901**. Multi-touch systems can also have one or more driver ICs. One exemplary multi-touch capable system, described in the incorporated references includes three ICs: a multi-touch controller, an external level-shifter/decoder, and controller, such as an ARM processor. The ARM processor can exercise low-level control over the multi-touch controller, which can subsequently control the level-shifter/decoder. A system host processor can exercise high-level control over and receive touch data from the ARM processor. In some embodiments, these drivers can be integrated into a single IC.

FIG. **25** shows an example high-level block diagram for a Touch/LCD Driver integrated circuit **2501**. The IC has two main functions: 1) LCD control and update, and 2) touch scanning and data processing. These two functions can be integrated by an LCD driver portion **2502** for LCD control and an ARM processor **2503** and multi-touch controller **2504** for touch scanning and processing. The touch circuits can be synchronized with LCD scanning to prevent one from interfering with the other. Communication between the host and either the LCD Driver or the ARM processor can be through the host data and control bus **2505**. A more fully integrated Touch/LCD Driver is discussed below.

As shown in FIG. **26**, an FPC **2601** that brings together the signals for the various touch and display layers can have three connector tabs, a T-tab **2602**, a B-tab **2603**, and a host tab **2604**. The T-tab can connect to sense line pads on the top glass. The T-tab traces **2605** can connect to corresponding pads on B-tab **2603**, which can also attach to the bottom glass. B-tab **2603** can also provide pass-through routes **2606** from Host tab **2604** that can enable the host to connect to the Touch/LCD Driver IC. FPC **2601** can also provide the substrate for various components **2607** supporting touch and LCD operation, and can also connect to the backlight FPC through two pads **2608**.

The FPC **2601** can be TAB bonded to both the top and bottom glass. Alternatively, other bonding methods can be employed.

2.2.1.4. Concept A: Touch Drive Integrated on Bottom Glass

A level shifter/decoder chip, along with a separate voltage booster (e.g., a 3V to 18V booster), can provide high voltage drive circuitry for touch sensing. In one embodiment, the Touch/LCD Driver IC can control the level shifter/decoder chip. Alternatively, the voltage booster and/or the level shifter/decoder can be integrated into the Touch/LCD Driver IC. For example, such integration can be realized using a high voltage (18V) LTPS process. This can allow integrating the level shifter/decoder chip and the voltage booster into the periphery of the bottom glass. The level shifter/decoder can also provide the voltages for V_{COM} modulation and touch drive as discussed below.

2.2.1.5. Concept A: Sharing Touch Drive with LCD V_{COM}

As discussed above, Concept A can add one layer of ITO to a standard LCD stackup, which can function as the touch sense lines. The touch drive layer can be shared with the LCD's V_{COM} plane, also denoted ITO2. For display operation, a standard video refresh rate (e.g., 60 fps) can be used. For touch sensing, a rate of at least 120 times per second can be used. However, the touch scanning rate can also be reduced to a slower rate, such as 60 scans per second, which can match the display refresh rate. In some embodiments, it may be desirable to not interrupt either display refresh or touch scanning. Therefore, a scheme that can allow the sharing of the ITO2 layer without slowing down or interrupting display refresh or touch scanning (which can be taking place at the same or different rates) will now be described.

Simultaneous display update and touch scanning is illustrated in FIG. 27. In this example, five multi-touch drive segments 2700, 2701, 2702, 2703, 2704 are shown. Each touch drive segment can overlap M display rows. The display can be scanned at 60 frames per second while the multi-touch sensor array can be scanned at 120 times per second. The illustration shows the time evolution of one display frame lasting 16.67 msec. The area of the display currently being updated preferably should not overlap an active touch drive segment.

Patch 2705 indicates where the display rows are being updated. Patch 2706 indicates an active touch drive segment. In the upper left corner of FIG. 27, at the start of the display frame the first M/2 display lines can be refreshed. At the same time, touch drive segment 1 2701 can be driven for the purpose of touch sensing. Moving to the right in the figure, at time $t=1.67$ ms, the next picture shows the next M/2 display rows being refreshed, while simultaneously touch drive segment 2 2702 can be driven. After about 8.3 msec of this pattern, (start of second row) each touch drive segment can have been driven once, and half the display will have been refreshed. In the next 8.3 msec, the entire touch array can be scanned again, thus providing a scanning rate of 120 fps, while the other half of the display is updated.

Because display scanning typically proceeds in line order, touch drive segments can be driven out of sequential order to prevent an overlap of display and touch activity. In the example shown in FIG. 27, the touch drive order was 1, 2, 3, 4, 0 during the first 8.3 msec and 1, 2, 4, 3, 0 in the second 8.3 msec period. The actual ordering can vary depending on the number of touch drive segments and the number of display rows. Therefore, in general, the ability to program the order of touch drive usage may be desirable. However, for certain special cases, a fixed sequence ordering may be sufficient.

It may also be desirable (for image quality reasons) to separate the active touch drive segment farther away from the area of the display being updated. This is not illustrated in FIG. 27, but can easily be done given a sufficient number of touch drive segments (e.g., 6 or more segments).

Such techniques can effectively allow different refresh rates for the display and touch-sense elements without requiring multiplex circuitry to support a high-frequency display drive element.

2.2.1.6. Concept A: V_{CST} Drive Options

As illustrated in FIG. 7, V_{CST} and V_{COM} can be connected together and can thus be modulated together to achieve the desired AC waveform across the LC. This can help achieve proper display refresh when using V_{COM} modulation. When V_{COM} is used for touch drive, it is not necessary to also modulate V_{CST} . This can be considered as the Open Circuit V_{CST} Option, described below. However, if V_{CST} is modulated with V_{STM} , the capacitive load on the touch drive signal, V_{STM} , can be reduced, which can lead to a smaller phase delay in the touch signal. This can be considered as the Drive V_{CST} Option, described below.

FIG. 28 illustrates the Open Circuit V_{CST} Option. Bottom drawing 2802 illustrates how one touch drive segment 2803 can overlap M display rows 2804. Touch drive segments 2803 located on the top glass can connect electrically to circuits on the bottom glass through a conductive dot 2805. The M V_{CST} lines of the M rows under the touch drive segment can connect together on the edge of the display 2806. Top drawing 2801 shows the basic circuit for a subpixel with its separate storage capacitor C_{ST} . Area 2807 in the upper drawing can represent M contiguous rows of subpixels covered by a single touch drive segment. Display operation and touch sensing for a particular touch drive/display group can occur at different

times, as discussed above. When the display driver is ready to set the state of the subpixels in the M rows, switches 2808, 2809 can connect V_{COM} Drive 2810 to the M V_{CST} lines 2804 and to the touch drive segment (V_{COM}). The V_{COM} Drive voltage can be set by the LCD driver to either ground or the supply rail, depending on the phase of the inversion. Later, when this touch drive/display group is available for touch usage, switches 2808, 2809 can connect the touch drive segment to V_{STM} 2811 and disconnect V_{CST} from V_{COM} Drive 2810, thus leaving it in the open state 2812.

FIG. 29 illustrates the Drive- V_{CST} option. Bottom drawing 2902 illustrates how one touch drive segment 2903 can overlap M display rows 2904. The touch drive segments 2903 located on the top glass can connect electrically to circuits on the bottom glass through conductive dot 2905. The M V_{CST} lines of the rows under a particular touch drive segment can connect together on the edge of the display 2906. Top drawing 2901 shows the basic circuit for a subpixel having a separate storage capacitor C_{ST} . Area 2907 in the upper drawing can represent M contiguous rows of subpixels covered by a single touch drive segment. Display operation and touch sensing can occur at different times. When the display driver is ready to set the state of the subpixels in the M rows, switch 2908 can connect V_{COM} Drive 2910 to the M V_{CST} lines 2904 and to the touch drive segment (V_{COM}). The V_{COM} Drive 2910 voltage can be set by the LCD driver to typically either ground or a supply rail depending on the phase of the inversion. Later, when this touch drive/display group is available for touch usage, switch 2908 can connect the V_{CST} and the touch drive segment (V_{COM}) to V_{STM} 2911.

2.2.1.7. Concept A: MT-Drive Capacitive Loading

The capacitive load on Concept A's touch drive line can be high, for example, because of the thin (e.g., ~ 4 μm) gap between the touch drive layer and the bottom glass, which can be covered by a mesh of metal routes and pixel ITO. The liquid crystals can have a rather high maximum dielectric constant (e.g., around 10).

The capacitance of the touch drive segment can affect the phase delay of the stimulating touch pulse, V_{STM} . If the capacitance is too high, and thus there is too much phase delay, the resulting touch signal can be negatively impacted. Analysis performed by the inventors indicates that keeping ITO2 sheet resistance to about 30 ohms/sq or less can keep phase delay within optimal limits.

2.2.1.8. Concept A: Electrical Model and V_{COM} -Induced Noise

Because ITO2 can be used simultaneously for both touch drive and LCD V_{COM} , modulating V_{COM} can add noise to the touch signal.

For example, a noise component may be added to the touch signal when one touch drive segment is being modulated with V_{COM} at the same time another touch drive segment is being used for touch sensing. The amount of added noise depends on the phase, amplitude, and frequency of the V_{COM} modulation with respect to V_{STM} . The amplitude and frequency of V_{COM} depend on the inversion method used for the LCD.

FIG. 30 shows an electrical model for the situation where touch drive 3001 is used for both touch sensing and LCD V_{COM} modulation. The model shows the input path through which V_{COM} modulation can add noise to the input of charge amplifier 3002.

In some embodiments, charge amplifier 3002 may need additional headroom to accommodate noise induced by V_{COM} 3003. Additionally, subsequent filtering circuits (e.g., synchronous demodulators, not shown) may need to remove the noise signal due to the V_{COM} modulation.

2.2.1.9. Concept A: V_{STM} Effects

V_{STM} modulation, under certain conditions, can have a negative impact on the voltages of the subpixels underneath the touch drive segment being modulated. If the subpixel RMS voltage changes appreciably, display artifacts may be produced. One or more of the following techniques may be employed to minimize display distortion that may result.

Touch drive from two sides can reduce the distortion of the LC pixel voltage. As shown in FIG. 31, touch drive from both sides can be achieved by employing the existing low resistance C_{ST} routes 3101 on the bottom glass by connecting V_{STM} to C_{ST} lines on both sides through conductive dots 3102. Alternatively, single-ended touch drive can produce a pixel offset voltage that is uniform for all pixels, which can be reduced or eliminated by adjusting the data drive levels. Also, reducing the ITO sheet resistance can help reduce display artifacts. Finally, the phase and frequency of V_{STM} can also be tied to the phase and frequency of V_{COM} to reduce the amount of noise in the touch signal.

2.2.1.10. Concept A: Impact on Manufacturing

The manufacturing process for Concept A can include additional steps relative to a typical LCD manufacturing process. Some may be new steps entirely and some may be modifications to existing steps. FIG. 32 shows a manufacturing process flow for Concept A. Blocks 3201, 3202, and 3204 represent new steps, and blocks 3205, 3206, and 3207 represent a modified step, both relative to a conventional LCD manufacturing processes (e.g., that of FIG. 8).

Applying and patterning ITO1 (blocks 3201, 3202) can be done using known methods. The ITO can be protected during the remainder of the LCD processing. Photoresist can be used to provide a removable protective coating. Alternatively, silicon dioxide can provide a permanent protective covering. ITO2 can be applied and patterned (block 3204) to form the touch drive segments in similar fashion.

An analysis of phase delay indicates that the sheet resistance of ITO1 and ITO2 can be as high as 400 ohms/square for small displays (<=4" diagonal), provided that the capacitive loading on either plane is small. As discussed above, the capacitive loading with Concept A can be of such magnitude that it may be desired to limit the maximum sheet resistance for ITO2 to around 30 ohms/square or less.

2.2.2. Concept A60

Concept A60 can be physically similar to Concept A and can provide a different approach to the problem of synchronizing display updates and touch scanning. This can be accomplished by using the I-line inversion of V_{COM} as the stimulus for the touch signal (i.e., V_{STM}). This is illustrated in FIG. 33, which shows how a single touch drive segment 3301 can be modulated while other touch drive segments can be held at a constant voltage. With this approach, the problem of removing the unwanted V_{COM} -induced noise from the touch signal can be eliminated. Furthermore, it is not necessary to spatially separate display updating and touch sensor scanning. However, using this approach, demodulation can be done at a single frequency (i.e., the V_{COM} modulation frequency, e.g., ~14.4 kHz) as opposed to the multi-frequency demodulation described in U.S. patent application Ser. No. 11/381,313, titled "Multipoint Touch Screen Controller," filed May 2, 2006, incorporated by reference herein. Furthermore, using this approach, the touch sensor scan rate can be fixed at the video refresh rate (e.g., 60 per second).

2.2.3. Concept B

Concept B, illustrated in FIG. 34, can be similar to Concept A, sharing many of the same electrical, cabling, and structural aspects. However, Concept B can integrate the touch drive layer into the V_{COM} layer. Concept B can therefore differ in

the number and stack position of ITO layers used for LCD and touch sensing. Because of the similarities, Concept B will now be described by highlighting differences between Concepts A and B.

Concept B can split the shared ITO2 layer of Concept A into two ITO layers, using one layer for touch sensing (ITO2) 3402 and one layer for the LCD V_{COM} (ITO3) 3403. Starting from the top, layers used for touch sensing can include: ITO1 3401, an ITO layer that can be patterned into N touch sense lines; ITO2 3402, an ITO layer that can be patterned into M touch drive lines; and ITO3 3403, an ITO layer that can serve as the V_{COM} electrode for the LCD. Touch drive layer (ITO2) 3402 can be deposited on the lower surface of top glass 3404, above the color filter 3405.

Separating V_{COM} from touch drive elements can reduce interference.

2.2.3.1. Concept B: Touch Sensor Electrodes

Concept B can include touch sensor electrodes substantially similar to those described above for Concept A.

2.2.3.2. Concept B: Conductive Dots

As in Concept A, Concept B can use additional conductive dots 3406, which can be located in the corners of the LCD, to connect the touch drive segments to dedicated circuitry. Because V_{COM} need not be shared with touch sensing, Concept B can retain the corner dots that connect V_{COM} to its drive circuitry. Additionally (as discussed below), Concept B may add even more conductive dots for V_{COM} .

2.2.3.3. Concept B: Flex Circuit and Touch/LCD Driver IC

Concept B can use a FPC and Touch/LCD Driver IC substantially similar to those described for Concept A.

2.2.3.4. Concept B: Synchronization with LCD Scanning

For Concept B, although the V_{COM} layer can be separate from the touch drive layer, it still may be desired to synchronize touch scanning with LCD updating to physically separate the active touch drive from the display area being updated. The synchronization schemes previously described for Concept A can also be used for Concept B.

2.2.3.5. Concept B: MT-Drive Capacitive Loading

As with Concept A, the capacitive load on Concept B's touch drive line can be high. The large capacitance can be due to the thin (e.g., ~5 μm) dielectric between touch drive (ITO2) 3402 and V_{COM} plane (ITO3) 3403. One way to reduce undesirable phase delay in the touch stimulus signal can be to lower the ITO drive line resistance through the addition of parallel metal traces. Phase delay can also be reduced by decreasing the output resistance of the level shifter/decoder.

2.2.3.6. Concept B: Electrical Model and V_{COM} -Induced Noise

Because the entire V_{COM} plane can be coupled to the touch drive layer, multi-touch charge amplifier operation may be disrupted by noise induced by V_{COM} modulation. To mitigate these effects Concept B can have a constant V_{COM} voltage.

Conversely, the coupling between ITO2 3402 and ITO3 3403 (V_{COM} and touch drive) can cause interference with the V_{COM} voltage that can cause the wrong data voltage can be stored on the LC pixel. To reduce the modulation of V_{COM} by V_{STM} , the number of conductive dots connecting V_{COM} to the bottom glass can be increased. For example, in addition to V_{COM} dots at each corner of the viewing area, conductive dots can be placed at the middle of each edge.

Distortion resulting from V_{COM} - V_{STM} coupling can be further reduced by synchronizing V_{STM} with V_{COM} and turning off the pixel TFT at just the right time. For example, if the line frequency is 28.8 kHz, and the touch drive frequency is a multiple of this (e.g., 172.8, 230.4 and 288 kHz) then the V_{COM} distortion can have the same phase relationship for all pixels, which can reduce or eliminate visibility of the V_{COM}

distortion. Additionally, if the gates of the pixel TFTs are turned off when the distortion has mostly decayed, the LC pixel voltage error can be reduced. As with Concept A, the phase and frequency of V_{STM} can be tied to the phase and frequency of V_{COM} to reduce the amount of noise in the touch signal.

2.2.3.7. Concept B: Impact on Manufacturing

As with Concept A, Concept B can also add steps to the LCD manufacturing process. FIG. 35 shows a manufacturing process flow for Concept B, in which blocks 3501, 3502, 3503, and 3504 represent new steps relative to a conventional LCD manufacturing process (e.g., that depicted in FIG. 8), and blocks 3506, 3507, 3508, and 3509 represent a modification to an existing step (e.g., also relative to FIG. 8).

ITO1 can be applied (block 3501) and patterned (block 3502) using known methods, as with Concept A. The sheet resistance of ITO1 and ITO2 can also be substantially similar to that described for Concept A. For Concept B, the ITO2 layer deposition (block 3503) can be routine because it can be directly applied to glass. Electrical access between the ITO2 layer and the bottom glass for the conductive dots that connect to the touch drive segments can be easily accomplished by etching using a shadow mask (block 3504).

ITO3 (e.g., the LCD's V_{COM} layer), which can have a sheet resistance between 30 and 100 ohms/square, can also be applied (block 3505) using conventional methods. However, as discussed above, V_{COM} voltage distortion can be reduced by reducing the resistance of the ITO3 layer. If necessary, lower effective resistance for ITO3 can be achieved by adding metal traces that run parallel to the touch drive segments. The metal traces can be aligned with the black matrix so as to not interfere with the pixel openings. The density of metal traces can be adjusted (between one per display row to about every 32 display rows) to provide the desired resistance of the V_{COM} layer.

2.2.4. Concept B'

Concept B' can be understood as a variation of Concept B that eliminates the ITO2 drive layer and instead uses a conductive black matrix (e.g., a layer of CrO_2 below the top glass) as the touch drive layer. Alternatively, metal drive lines can be hidden behind a black matrix, which can be a polymer black matrix. This can provide several benefits, including: (1) eliminating an ITO layer; (2) reducing the effect of V_{STM} on the V_{COM} layer; and (3) simplifying the manufacturing process. The manufacturing process can be simplified because using the black matrix for touch drive can eliminate the need to pattern an ITO layer above the color filter.

FIG. 36 shows a side view 3601 and top view 3602 of Concept B'. As can be seen, side view 3601 looks very much like a standard LCD stack-up, except for the top layer of ITO 3603 used for touch sensing. The bottom diagram of FIG. 36 shows how the black matrix 3604 can be partitioned into separate touch drive segments. The mesh pattern can follow the pattern of a conventional black matrix, except that each drive segment can be electrically isolated from the other segments. To compensate for reduced touch signal strength that can be caused by using the black matrix mesh for touch drive, the charge amp gain can be increased (e.g., about 4x).

Because the touch sensing layer may not be shielded from the V_{COM} layer, V_{COM} modulation may interfere with the touch signal. Furthermore, touch drive may still interfere with the V_{COM} voltage. Both of these issues can be addressed by segmenting the V_{COM} layer as described with Concept A and/or spatially separating display updating and touch sensing as described above. A constant V_{COM} voltage can also be used to address these issues.

2.2.5. Concept K

Concept K is illustrated in FIGS. 37 (circuit diagram) and 38 (stackup diagram). Concept K utilizes the fact that select pulses in the TFT LCD can be partially transferred to the pixel ITO when the C_{ST} -on-gate configuration is used.

As shown in the display stackup of FIG. 38, the viewer can face active array plate 3801 rather than CF plate 3802. ITO pixels 3803 on the active array can provide the V_{STM} pulses for the touch sensor, with the display rows alternatively being used for V_{STM} pulses and for display addressing. ITO sense layer 3804 on plastic polarizer 3805 can be laminated to the back of array plate 3801 to provide the touch-sensing layer. A thin glass layer (e.g., 0.2 mm) can help improve the signal-to-noise ratio.

During display updates, rows can be selected individually to update the pixel data (as shown in FIG. 39). To generate V_{STM} for touch sensing, multiple rows 4001 can be selected simultaneously, while high data voltage 4003 can be applied to the column lines 4002 to keep the TFTs off (as shown in FIG. 40). The column driver can adjust the timing of data signals from a display memory to accommodate the touch drive intervals.

In one embodiment, a touch pulse sequence can simultaneously pulse about 30 rows 4001 during a touch scan interval. FIG. 41 shows the effect of a touch drive pulse (V_{STM}) on the subpixel voltages of the LCD. The added voltage from the V_{STM} pulses can be compensated by a DC offset of V_{COM} and/or gamma correction of the display data grey levels.

Concept K can allow a number of advantages. Because the display pixels and touch sensors share drive circuitry, the level shifter/decoder may be eliminated. Additionally, a conventional CF plate can be used. Furthermore, no extra conductive dots between the top and bottom glass are needed. Busline reflections may increase the reflectance (R) for portions of the display, and hence call for the use of an extra film under the buslines (such as CrO under Cr) that can reduce R.

2.2.6. Concept X'

Concept X' is illustrated in FIG. 42 (circuit diagram) and FIG. 43 (stackup diagram). Concept X' utilizes the fact that V_{STM} pulses can be similar to gate pulses for the TFT pixel switches (e.g., a 15 to 18 V swing). In Concept X', the touch drive segments 4301 can be part of the LTPS active array and can form the counter electrode for the pixel storage capacitors C_{ST} . C_{ST} can be formed between two ITO layers 4301, 4302. In this embodiment, the active array plate 4303, rather than the color filter plate 4304 can be on the user side of the display.

As shown in FIG. 42, a pulse sequence with three different frequencies 4201 for V_{STM} can be shared by three rows of pixels 4202 to select those rows. The ITO touch drive segments 4203 can be patterned under a set of rows adjacent to addressed rows. Touch drive segments 4203 can be connected to GND by TFTs 4204 when not connected to V_{STM} .

Changes that can be made to the processing steps to construct Concept X' can include the following. First, a patterned sense ITO can be added on the outside of the array substrate. Second, SiO_2 protection can be added on the sense ITO during LTPS processing. Protective resist could also be used. Third, touch drive ITO can be deposited and patterned under the SiO_2 barrier layer (which can be found in typical LTPS processes) for the LTPS array. Finally, vias can be patterned in the barrier SiO_2 to contact the touch drive ITO layer. This step can be combined with a subsequent process step.

Concept X' can allow a number of advantages. For example, because the display and touch sensors share drive circuitry, the level shifter/decoder chip can be eliminated.

Additionally, no change to the CF plate is required, so conventional color filter processing can be used. Further, because the storage capacitor C_{ST} can be located between two ITO layers, high transmittance can be achieved. Another advantage can be that extra conductive dots between the array plate **4303** and CF plate **4304** may be eliminated.

2.3. Fully-Integrated Touch-Sensing

A third set of embodiments of the present invention fully integrate the touch-sensing elements inside the LCM. As with partially-integrated touch-sensing, existing layers in the LCM can serve double duty to also provide touch-sensing functionality, thereby reducing display thickness and simplifying manufacturing. The fully-integrated touch-sensing layers can also be protected between the glass layers.

In some embodiments, the fully-integrated LCD can include a V_{COM} layer similar to those described in previous embodiments. In other embodiments, the fully-integrated touch-sensing LCD can include in-plane-switching (IPS) LCD constructions, which are described in further detail in the following sections.

2.3.1. Fully-Integrated V_{COM} -Based LCDs

2.3.1.1. Concept A'

Concept A' can be considered as a variation of Concept A that eliminates the ITO sense layer (ITO1 **2001** in FIG. **20**) in favor of a conductive black matrix layer (below the top glass) used as the touch sense layer. Alternatively, metal sense lines can be hidden behind a black matrix, which can be a polymer black matrix. As a result, Concept A' can also eliminate the T-tab on the FPC and the corresponding bonding to the top glass. Touch sense lines can be routed through conductive dots to the bottom glass and can directly connect to the Touch/LCD Driver chip. Furthermore, the FPC can be a standard LCD FPC. Elimination of manufacturing steps and components can lead to a reduction in cost compared to Concepts A and B.

FIG. **44** shows one way substitution of a conductive black matrix for the touch sense layer can be accomplished. FIG. **44** includes a side view **4401** of the upper portion of a single pixel with its black matrix **4403** running between primary color sections **4404**. Touch drive segment **4405** can be separated from black matrix lines **4403** by planarizing dielectric layer **4406**. FIG. **44** also shows top view **4402** of the display with black matrix lines **4403** running vertically. Approximately 96 black matrix lines (e.g., 32 pixels worth) can connect together into the negative terminal of charge amplifier **4907**. Touch drive segments **4405** can be driven as described above. A finger approaching top glass **4408** can perturb the electric field between vertical black matrix lines **4403** and touch drive segment **4405**. The perturbation can be amplified by charge amplifier **4407** and further processed as described elsewhere herein.

Because of the depth of touch sense lines **4403** in the display, the minimum distance between a finger or touch object and sense lines **4403** may be limited. This can decrease the strength of the touch signal. This can be addressed by reducing the thickness of layers above the touch sense layer, thereby allowing a closer approach of the finger or other touch object to the sense lines.

2.3.1.2. Concept X

Concept X is illustrated in FIGS. **45** and **46**. The stack-up for Concept X, shown in FIG. **45**, can be basically identical to that of a standard LCD. Touch sense layer **4501** can be embedded within the V_{COM} layer (ITO2), which can serve the dual purpose of providing the V_{COM} voltage plane and acting as the output of the touch sensor. The touch drive layer can also be embedded within an existing LCD layer. For example, touch drive can be located on bottom glass **4503** and can be

part of the LCD select line circuitry (see FIG. **5**). The select circuit can thus serve a dual purpose of providing gate signals for the subpixel TFTs and the touch drive signal V_{STM} . FIG. **46** is a top view of Concept X showing one possible arrangement of the touch sense layer with its floating pixels **4601** embedded in the V_{COM} layer.

2.3.1.3. Concept H

Concept H is illustrated in FIGS. **47-50**. Concept H need not include any ITO outside the top glass or plastic layer of the display. As a result, the manufacturing processes can be very similar to existing display manufacturing processes.

As shown in FIG. **47**, the touch-sensing part of the screen can be a transparent resistive sheet **4701**, for example, a glass or plastic substrate having an unpatterned layer of ITO deposited thereon. The V_{COM} layer of the display may be used for this touch-sensing part. Because this layer need not be patterned, a photolithography step can be eliminated from the manufacturing process as compared to some embodiments discussed above. For purposes of reference herein, the sides will be referred to as north, south, east, and west as indicated in the drawing.

A plurality of switches **4702** can be arranged about the perimeter of the resistive sheet. These switches can be implemented as TFTs on glass. Also shown are a plurality of conductive dots **4703**, at each switch location, that can connect V_{COM} (on the top glass) to the TFT layer on the bottom glass, in the border region of the display. Switches **4702** can be connected together into two busses, for example, with the north and east switches connected to one bus **4704** and the south and west switches connected to a second bus **4705**.

For touch sensing, switches **4702** can be operated as follows. The north and south switches can be used to measure the Y-direction capacitance. The left and right side switches can be used to measure the X-direction capacitance. The switches at the northeast and southwest corners can be used for both X and Y measurement. Capacitance can be measured by stimulating resistive sheet **4701** with a modulation waveform V_{MOD} , illustrated in FIG. **49**. The current (i.e., charge) required to drive the sheet to the desired voltage can be measured and used to determine the location of the touch.

Specifically, as illustrated in the waveforms for FIG. **49**, in the absence of touch, the baseline capacitances **4902** can indicate the current (charge) required to stimulate the sheet **4701** to the V_{MOD} voltage. In the presence of touch, greater current **4903** (charge) may be required because of the capacitance of the finger. This greater current is illustrated in the lower group of waveforms. The position of the touch can then be determined by simple mathematical combination of the baseline and signal waveforms as illustrated in FIG. **49**.

An equivalent circuit for the touch screen during the X-direction (i.e., east-west) measurement is illustrated in FIG. **48**. C_{PARA} **4801** can be the distributed parasitic resistance of the sheet, and C_{FINGER} **4802** can be the capacitance of a touch, e.g., located approximately 75% of the way to the east side. The block diagrams indicate how the plate can be driven to V_{MOD} and how the charge can be measured, combined, processed, and sent to the host.

FIG. **50** illustrates how Concept H can be integrated with an LCD. Specifically, conductive dots **5001** can connect to the TFT layer, which can allow resistive sheet **5002** (V_{COM}) to be modulated for display operation. Touch sensing operation and display operation can be time multiplexed. For example, assuming a 60 Hz screen refresh rate, corresponding to a 16 ms LCD update period, part of this time can be used for writing information to the LCD, and another part can be used for touch sensing. During LCD updating, V_{MOD} can be V_{COM} from the LCD driver circuit. During touch sensing, wave-

forms having different frequencies and amplitudes may be used depending on the exact details of the touch system, such as desired SNR, parasitic capacitances, etc. It should also be noted that the touch-sensing circuitry in this embodiment, illustrated in block diagram form, can either be integrated into the LCD driver or can be a separate circuit.

2.3.1.4. Concept J

Concept J, like Concept H, need not include any ITO outside the top glass or plastic layer of the display. Physical construction of Concept J is illustrated in FIG. 51. The touch-sensing surface can be a resistive sheet **5101** like Concept H, but patterned into a number of row strips **5102**. Patterning may be accomplished by photolithography, laser deletion, or other known patterning techniques. By patterning resistive sheet **5101** into a plurality of strips **5102**, the switches along the top and bottom (north and south) can be eliminated, leaving east and west switches **5103** connected to the row strips. Each row **5102** can be stimulated in sequence, using, for example, the V_{MOD} waveform **5201** illustrated in FIG. 52. The current (charge) required to drive each row **5102** to the modulation voltage can be a function of the capacitance of the row, which can be a combination of the parasitic capacitance (C_{PARA} **5301**, FIG. 53) for a given row and the capacitance of the finger or other touch object (C_{FINGER} **5302**, FIG. 53).

As shown in FIG. 52, the signal in the presence of touch **5202** can be mathematically combined with the baseline signal **5203** to compute the coordinates of the touch. The Y outputs can be determined by the centroids of Z outputs for each row. The X outputs can be determined by a weighted average of the X outputs for each row.

FIG. 54 shows how the Concept J touch sensor can be integrated with an LCD. Conductive dots **5401** can connect V_{COM} on the top glass to the TFT layer on the bottom glass. Touch and display operations need not be time division multiplexed. Rather, while a portion of the display is being updated, another portion may be scanned for touch. Various techniques for so doing are discussed above with respect to other embodiments. The touch sensing may use different frequencies and amplitudes, but may be phase synchronized with the LCD row inversion. Switches **5402** can be implemented as TFTs on glass. The measurement circuitry can either be integrated with the LCD controller or a separate component.

2.3.1.5. Concept L

In Concept L, active TFT layers can be added to the color filter glass to allow a segmented ITO layer to provide multiple functions simultaneously across different regions of an LCD display. A stackup diagram for Concept L is illustrated in FIG. 55. Concept L can contain the same number of ITO layers as a standard LCD display. However, while ITO1 **5509** and other structures **5507**, **5508** on bottom glass **5511** can remain standard, an active TFT layer **5501** on the color filter glass **5505** can allow a region (e.g., a horizontal row) of ITO2 **5504** to be switched between the role of V_{COM} , touch drive, or touch sense.

FIG. 56 illustrates a Concept L display with a horizontally-segmented ITO2 layer **5504**. Different regions of the display are concurrently: undergoing V_{COM} modulation (region **5601**) and/or being written (region **5602**); providing touch stimulus (region **5603**); being measured to provide touch sense (region **5604**); and maintaining a hold state (region **5605**). The transistors in the active TFT layer **5501** can switch the signals for each horizontal row to the desired function for a specified time interval. Each region can have equal exposure to each state, in the same sequence, to substantially eliminate non-uniformity. Because providing touch stimulus may dis-

turb the voltage across the LC, LCD pixel writing can take place just after the touch stimulus phase to reduce the time duration of any disturbance. LCD pixel writing for a region can occur during V_{COM} modulation, while adjacent segments can be undergoing V_{COM} modulation to maintain uniform boundary conditions during pixel writing.

The color filter plate can be formed using a process similar to the process used for the active array. Forming the additional TFT layers may involve additional steps, but the back-end processing of the two substrates can remain substantially similar to that of a standard LCD. These techniques can allow such displays to scale to larger-sized panels without using low-resistivity ITO.

2.3.1.6. Concepts M1 and M2

FIGS. 57 and 58 show stackup diagrams for Concepts M1 and M2, respectively. Concepts M1 and M2 can add layers of patterned ITO and metal to the color filter glass for touch sensing. While concepts M1 and M2 are similar, one difference relates to different uses of the ITO1 and ITO2 layers. Concept M1 can use ITO1 **5701** for touch sense and can use ITO2 **5702** for both V_{COM} (when setting/holding LCD pixel voltages) and touch drive (when not writing pixel voltages). Concept M2 can use ITO1 **5801** for touch drive, and can use ITO2 **5802** for V_{COM} and touch sense. For both Concepts M1 and M2, top glass **5703**, **5803** need not include any transistors or other active components.

In either concept M1 or M2, V_{COM} can be segmented to allow one region of the display to keep a constant V_{COM} during display updating while another region can be independently scanned for touches. This can reduce interference between the touch-sensing and display functions.

FIGS. 59, 60, and 61 show an exemplary display (corresponding to Concept M2) that has been segmented into three regions (**5901**, **5902**, **5903**; FIG. 59), and wherein two regions can be simultaneously touch-scanned (e.g., regions **5901**, **5902**) while a third region's display pixels can be updated (e.g., region **5903**). On the left side of FIG. 61, twenty seven vertical drive lines **6101** in the ITO1 and M1 (metal 1) layers can provide three different regions with nine touch columns each. Each drive line (3 per touch column) can have a conductive dot (not shown) down to the array glass, and can be routed to a driver ASIC.

The right side of FIG. 61 shows the possible modes for the segmented horizontal rows of the ITO2 layer, which include V_{COM} and V_{HOLD} for a first set of alternating rows **6102** and V_{COM} , V_{HOLD} , and V_{SENSE} for a second set of alternating rows **6103**. Each ITO2 row can connect via a conductive dot (not shown) down to the array glass, from which the mode of the row can be switched using LTPS TFT switches. The right side of FIG. 61 shows twenty-one sense rows, of which fourteen can be sensed at any time (although other numbers of rows could also be more).

FIG. 62 shows the circuit diagram for touch sensing in the exemplary display illustrated in FIGS. 59, 60, and 61. V_{STM} driver **6200** sends a signal through metal drive column **6202**, which can have a resistance of R_{metcol} and a parasitic capacitance of C_{drv} . Touch capacitance C_{sig} can be measured across the ITO row, which can have a resistance of $R_{ito2row}$ and a parasitic capacitance of $C_{ito2row}$. The touch-sensing charge can also be affected by two additional resistances, R_{sw1} and R_{border} , before reaching charge amplifier **6204**.

A display frame update rate of 60 fps can correspond to a touch scan rate of 120 fps. If desired (e.g., in small multi-touch displays) designers may choose to reduce the touch scan rate (e.g., to 60 fps), thereby saving power and possibly reducing complexity. As a result, some regions of the display

can be left in a “hold state” when neither display updating nor touch scanning is occurring in that region.

FIG. 63 shows a display in which the display regions can be scanned and updated horizontally instead of vertically (as in FIG. 60). The touch drive and touch sense regions can be interleaved so that a stimulus applied to touch drive row 6301 can be simultaneously sensed from two sense rows 6302 and 6303, as indicated by sense field lines 6305.

The black mask layer can be used to hide metal wires and/or gaps in ITO layers. For example, the metal drive lines, etched gaps in ITO2, and etched gaps in ITO1 can be fully or partially hidden behind the black mask (as shown in FIG. 64). This can reduce or eliminate the visual impact these items may have on the display’s user.

2.3.1.7. Concept M3

As shown in FIG. 65, Concept M3 can be similar to Concepts M1 and M2, but with touch drive and touch sense integrated into a single, segmented ITO layer 6501. While various embodiments described above included drive and sense electrodes on separate layers, Concept M3 can include drive and sense electrodes in the same plane. A dielectric layer 6502 can be added to shield the touch-sensing elements from other electrical fields and/or effects.

FIGS. 66 and 67 illustrate a Concept M3 display segmented into three regions 6601, 6602, 6603, each of which can alternate through a touch stim/sense phase, a LCD pixel writing phase, and a hold phase during every cycle update of the display frame. FIG. 68 illustrates a wiring detail and layout arrangement that enables partitioning the display. ITO1 rows 6801 can connect via conductive dots 6802 to LTPS switches on the TFT glass that switch the voltage for the row between V_{COM} and V_{HOLD} . Three sense lines 6803 can be used for each column (one sense line for each region), with the lines multiplexed so that the signal for the active region can be measured in the corresponding timeframe. During touch scanning for a region, the touch drive elements corresponding to a row in the region can be activated, and all of the columns for that row can be simultaneously sensed. During the time that one region of the display is scanned for touches, another region can be modulating V_{COM} and/or updating the display pixels.

Metal segments (6805 in FIG. 68) can be added to regions of the ITO to reduce the resistance of the ITO. For example, short metal segments can be added to the ITO1 drive electrodes 6804 to reduce phase delay of the touch signal. These metal lines may be hidden behind a black mask layer.

As illustrated in FIG. 69, guard traces 6903 can be used to block field lines between the touch and sense electrodes that do not pass up through the glass where they would be affected by a finger or other touch object. This can reduce noise and enhance the measured effect of touches to the display. FIG. 70 shows a top-view 7001 and a cross-section 7002 of a display without guard traces, in which a narrow gap separates the rows of touch-sensing elements, e.g., drive electrodes 7003 and sense electrodes 7004. Grounding the ITO2 layer 7005 (V_{COM}) when touch sensing is active can shield touch sensing and display functions from one another. FIG. 69 shows a top-view 11101 and a cross-section 6902 of a display that includes grounded guard traces 6903 between rows of touch-sensing elements on ITO1, e.g., drive electrodes 6904 and sense electrodes 6905.

2.3.1.8. Concepts P1 and P2

Concepts P1 and P2, like Concept M3, can provide touch drive and touch sense electrodes in the same plane. However, Concepts P1 and P2 can provide an additional benefit of individually-addressable touch-pixels, as shown in FIG. 71.

Each touch pixel can include a drive electrode 7102, a sense electrode 7103, and corresponding drive lines 7104 and sense lines 7105 that can be individually routed and connected to a bus on the border of the display. These lines may be formed using conductive black mask, thereby allowing black mask areas already present in the display to provide additional service for touch sensing. Alternatively, the lines may be metal lines disposed behind a black matrix, which can be a polymer black matrix.

FIG. 72 shows a stackup diagram for Concept P1. Concept P1 can differ from a standard LCD process in various respects. For example, a portion of the standard polymer black mask can be changed to black chrome with low-resistance metal backing. These conductive lines can then be used to route signals to and from the touch pixels. A layer of patterned ITO 7202 can be added behind the black mask in an additional mask step. STN-style conductive dots 7203 can be added to route the drive and sense signals for each touch pixel to the LTPS TFT plate (e.g., using 2 dots per touch pixel). The color filter layer and the bordering planarization layer 7204 can also be thickened to decrease the capacitance between the touch drive and V_{COM} .

FIG. 73 shows a stackup diagram for Concept P2. In addition to incorporating the four changes described above with respect to Concept P1, Concept P2 can also include a patterned ITO layer 7301 that can be used to create a segmented V_{COM} . Segmenting V_{COM} can isolate touch drive and display operation, thereby potentially improving the signal-to-noise ratio. FIG. 74 shows a circuit diagram highlighting the V_{COM} signal coupling for Concept P2. Keeping independent buses (Vholdbus1 and Vholdbus2) for return current can reduce the coupling charge. Also, using complementary drive for half of the touch pixels can reduce the return current in Vholdbus1.

FIGS. 71 and 75 illustrate an exemplary routing of touch sense and touch drive lines to and from the sense and drive pixels. A set of drive and sense lines can be routed horizontally from bus lines 7501, 7502 at the sides of the display to each individual touch pixel 7101. These lines can be hidden behind a black mask layer, or can be incorporated into a conductive black mask layer. This routing can also be on a single layer. Signals for individual touch pixels can be addressed and multiplexed through the bus lines using LTPS TFTs.

The ability to drive individual pixels, rather than whole rows, can be used to reduce parasitic capacitance. Individually-addressable touch pixels can also allow the touch array to be scanned in “random access” mode, rather than just row-by-row. This can increase flexibility in interlacing touch sensing and display updating. For example FIG. 76 illustrates a possible scan pattern. Because the system can scan the touch pixels in any desired pattern, a scan pattern can be designed that ensures that adjacent rows and adjacent pixels are never driven at the same time, thereby avoiding fringe field interaction that can result in signal loss or a lower signal-to-noise ratio. In FIG. 76, the squares 7601 and 7602 each comprise one drive electrode and one sense electrode. Squares 7601 correspond to in phase drive while squares 7602 correspond to 180 degree out-of-phase drive signal. In the figure, two rows (totaling twenty pixels) can be covered in five sequences, with four pixels scanned at a time.

2.3.1.9. Concept D

Another embodiment, Concept D, can support multi-touch sensing using two segmented ITO layers and an additional transistor for each touch pixel. FIG. 77 shows a circuit diagram for Concept D. During display updates, the circuit can function as in a standard LCD display. Gate drive 7700 can drive two transistors (Q1 7702 and Q2 7704), thereby allow-

ing signals from V_{COM} bus 7706 and data lines 7708 to transfer charge to a set of capacitors controlling the LC (C_{ST} 7710, C_{LC1} 7712, and C_{LC2} 7714). When transistor Q2 7704 is turned off V_{COM} 7706 is disconnected from C_{ST} 7710, allowing V_{COM} line 7706 to be used for touch sensing. Specifically, V_{COM} line 7706 can be used to send charge through C_{IN} 7716 and C_{OUT} 7718, through the data line 7708 (which acts as a touch sense line) into charge amplifier 7720. A conductive object (such as a user's finger, stylus, etc.) approaching the display can perturb the capacitances of the system in a manner that can be measured by the charge amplifier 7720.

FIGS. 78 and 79 show stackup diagrams for a sub-pixel in a Concept D-based display. In FIG. 78, the ITO1 layer can be segmented into two plates, A 7722 and C 7726. The ITO2 layer can be segmented into islands (e.g., B 7724) that can be located over sub-pixels and serve as the counter-electrodes to the plates in the ITO1 layer. During display update, voltage differences between island 7724 and the plates (A 7722, C 7726) can be used to control liquid crystal 7804. During touch sensing, perturbations to the capacitances throughout the sub-pixel (e.g., C_{lc1} , C_{lc2} , C_{in} , C_{out} , and C_{st} in FIG. 77) can be measured to determine the proximity of a conductive object.

FIG. 80 shows a combined wiring and stackup diagram for Concept D. FIG. 81 shows a physical realization for one embodiment of Concept D.

2.3.2. Fully-Integrated IPS-based LCDs

In-plane switching (IPS), as illustrated schematically in FIG. 82, can be used to create LCD displays with wider viewing angles. While some LCDs (such as twisted nematic LCDs) use vertically-arranged electrode pairs (e.g., as shown in FIG. 20), in IPS LCDs both electrodes 8201, 8202 used to control orientation of the liquid crystals 8203 can be parallel to one another in the same layer (e.g., in a single plane). Orienting the electrodes in this way can generate a horizontal electric field 8200 through the liquid crystal, which can keep the liquid crystals parallel to the front of the panel, thereby increasing the viewing angle. Liquid crystal molecules in an IPS display are not anchored to layers above or below (as shown in FIG. 82, for example), but instead can rotate freely to align themselves with electric field 8200 while remaining parallel to one another and the plane of the display electrodes. FIG. 83 shows a more realistic arrangement of an interdigitated pair of electrodes 8301, 8302 in a display that can use in-plane switching.

Because IPS displays lack a V_{COM} layer that can also be used for touch drive or touch sense, some embodiments of the present invention can provide touch-sensing capabilities by allowing the same electrodes used for display updating to also be used for touch sensing. These electrodes can be complemented by additional circuitry. In some embodiments discussed above, touch pixels can overlap a large number of display pixels. In contrast, because the IPS embodiments discussed below can use the same electrodes used for display control and touch sensing, higher touch resolution can be obtained with little to no additional cost. Alternatively, a number of touch pixels can be grouped to produce a combined touch signal with a lower resolution.

2.3.2.1. Concept E

One IPS embodiment, Concept E, is illustrated in FIG. 84. As mentioned above, the electrodes in IPS-based touch sensing displays can be in the same plane and can have an interdigitated structure (as shown in FIG. 84). While electrode A 8400 and electrode B 8402 can be used to orient the liquid crystal layer during display updating, these same electrodes can also be used (in combination with additional elements) to achieve touch sensing. For example, Concept E can use additional switches 8404 to change the drives for a set of signal

lines based on whether the pixel is undergoing display updating or touch-sensing. Concept E can also include capacitances (CIN_A 8406, COUT_A 8408, CIN_B 8410, and COUT_B 8412) and two transistors (transistor Q1 8414 and transistor Q2 8416) to control when the electrodes will be used for display updating or touch sensing.

During touch sensing, transistors Q1 8414 and Q2 8418 are turned off, disconnecting the electrodes from display signals and allowing the electrodes to be used to measure capacitance. The V_{COM} metal line 8416 can then be connected to touch stimulation signal 8418. This stimulation signal can be sent through CIN_A 8406 and CIN_B 8410 to COUT_A 8408 and COUT_B 8412, which can connect to charge amplifier 8422. A capacitance C_{STG} (not shown) between CIN and COUT can be used to detect touch. When the sense pixel is not being touched, charge delivered to the charge amplifier 8422 can depend mainly on the capacitance between the two pairs of CIN and COUT capacitors. When an object (such as a finger) approaches the electrodes, the C_{STG} capacitance can be perturbed (e.g., lowered) and can be measured by charge amplifier 8422 as a change in the amount of charge transferred. The values for CIN and COUT can be selected to fit a desired input range for charge amplifier 8422 to optimize touch signal strength.

The electrodes can be used to perform touch sensing without negatively affecting the display state by using a high-frequency signal during touch sensing. Because LC molecules are large and non-polar, touches can be detected without changing the display state by using a high-frequency field that does not change or impose a DC component on the RMS voltage across the LC.

FIG. 85 shows a stackup diagram for Concept E. As described, all touch elements can be formed on TFT plate 8501.

2.3.2.2. Concept Q

Another embodiment of an IPS-based touch-sensing display, Concept Q, also permits the TFT glass elements of an LCD (such as metal routing lines, electrodes, etc.) to be used for both display and touch sensing functions. A potential advantage of such an embodiment is that no changes to display factory equipment are required. The only addition to conventional LCD fabrication includes adding the touch-sensing electronics.

Concept Q includes two types of pixels, illustrated in FIGS. 105 and 106. Pixel type A is illustrated in FIG. 105. Each pixel 10501 includes three terminals, a select terminal 10502, a data terminal 10503, and a common terminal 10504. Each of the A type pixels have their common terminal connected along columns 10505 to form touch-sensing columns. Pixel type B is illustrated in FIG. 106. Each pixel 10601 also includes three terminals, select 10602, data 10603, and common 10604. Each of the B type pixels have their common terminal connected along rows 10605 to form touch sensing rows. The pixels can be arranged as shown in FIG. 107 with a plurality of touch sense rows 10702 and a plurality of touch sense columns 10703. A touch sensing chip 10701, which can include the drive stimulation and sensing circuitry can be connected to the rows and columns.

The touch sensing chip can operate as follows. During a first time period, all of the rows and columns can be held at ground while the LCD is updated. In some embodiments, this may be a period of about 12 ms. During a next time period the A type pixels, i.e., touch columns, can be driven with a stimulus waveform while the capacitance at each of the B type pixels, i.e., touch rows, can be sensed. During a next time period, the B type pixels, i.e., touch rows, can be driven with a stimulus waveform while the capacitance at each of the A

type pixels, i.e., touch columns, can be sensed. This process can then repeat. The two touch-sense periods can be about 2 ms. The stimulus waveform can take a variety of forms. In some embodiments it may be a sine wave of about 5V peak-to-peak with zero DC offset. Other time periods and waveforms may also be used.

2.3.2.3. Concept G

One issue that can arise in an IPS-based touch-sensing display is that a lack of shielding between the touch and the LC means a finger (or other touch object) can affect the display output. For instance, a finger touching the screen can affect the fields used to control the LC, causing the display to distort. One solution to this issue can be to put a shield (e.g., a transparent ITO layer) between the user and the display sub-pixels. However, such a shield can also block the electric fields used for touch sensing, thereby hindering touch sensing.

One embodiment, Concept G, overcomes this issue by flipping the layers of the display as shown in the stackup diagram in FIG. 86. This can place LC 8600 on the opposite side of the TFT plate 8602 from the user. As a result, the field lines used to control the LC 8600 can be generally oriented away from the touch side of the LCD. This can allow metal areas, such as the data lines, gate lines, and electrodes, that are now between the touching object and the LC 8600 to provide partial or full shielding for the LC.

2.3.2.4. Concept F

Another embodiment, Concept F (illustrated in FIG. 87), can reduce display perturbation while leaving the LCD data bus unchanged (in relation to non-touch IPS displays) and without requiring additional ITO layers or making the alignment of layers more difficult. Instead of using a shared data line (as in Concepts E and G), Concept F can reduce potential display perturbation by adding a set of routed metal lines in a metal layer (M1) that can serve as output sense lines 8700. These output sense lines 8700 can run vertically underneath the display circuitry across the full area of the display, as shown in FIG. 87 and in the stackup diagram for a Concept F sub-pixel shown in FIG. 88. By using a separate metal layer for output sense, Concept F can allow one of the transistors shown for Concept E (FIG. 84) to be removed. Note also that Concept F flips the layers of the display to further reduce potential display perturbation, as described above with respect to Concept G.

3. Enabling Technologies

A variety of aspects can apply to many of the embodiments described above. Examples of these are described below.

3.1. DITO

In many embodiments, ITO may be deposited and patterned on two sides of a substrate. Various techniques and processes for doing so are described in U.S. patent application Ser. No. 11/650,049, titled "Double-Sided Touch Sensitive Panel With ITO Metal Electrodes," filed Jan. 3, 2007, which is hereby incorporated by reference in its entirety.

3.2. Replacing Patterned ITO with Metal

Various embodiments can eliminate the patterned ITO layer that forms touch sense electrodes and replace this layer with very thin metal lines deposited on one of the layers, for example, on the top glass. This can have a number of advantages, including eliminating an ITO processing step. Additionally, the sense line electrodes may be made quite thin (e.g., on the order of 10 microns), so that they do not interfere with visual perception of the display. This reduction in line thickness can also reduce the parasitic capacitance which can enhance various aspects of touch screen operation, as described above. Finally, because the light from the display

does not pass through a layer substantially covered with ITO, color and transmissivity can be improved.

3.3. Use of Plastic for Touch Sense Substrate

Various embodiments described above have been described in the context of glass substrates. However, in some embodiments, cost savings and reduced thickness can be achieved by replacing one or more of these substrates with plastic. FIGS. 89 and 90 illustrate some differences between glass-based systems, illustrated in FIG. 89, and plastic-based systems, illustrated in FIG. 90. Although illustrated in the context of one particular embodiment, the principle of substituting a plastic substrate may be applied to any of the concepts.

FIG. 89 illustrates a stack up of a glass based system. Dimensions illustrated are exemplary using current technology, but those skilled in the art will understand that other thickness may be used, particularly as the various fabrication technologies advance. Starting from the top, a cover 8901, having an exemplary thickness of about 0.8 mm, can be above an index matching layer 8902 (e.g., approximately 0.18 mm thick). Below the index matching layer can be top polarizer 8903. The top polarizer 8903 can have a thickness of approximately 0.2 mm. The next layer can be glass layer 8904 (e.g., about 0.5 mm thick) having ITO patterned on each side. Sense electrodes can be patterned on the top side, for example, which can also be bonded to FPC 8905. The drive electrodes and V_{COM} layer for the LCD can be patterned on the bottom of glass layer 8905. Below this can be another glass layer 8906, having an exemplary thickness of about 0.3 mm, on which the TFT layers for the display can be formed. The top of this glass layer can also be bonded to FPC 8907 connecting to both the display and touch sensing circuitry 8908. Below this can be the bottom polarizer, below which can be the display backlight 8910.

The overall thickness from top to bottom can be approximately 2.0 mm. Various ASICs and discrete circuit components may be located on the glass or connected via the FPCs. Patterned ITO can be placed on another plastic layer, for example, the bottom side of the top cover, etc.

FIG. 90 illustrates a similar arrangement in which middle glass layer 9001 can be reduced in thickness by moving touch sense layer 9002 to plastic polarizer 9003. Patterning touch sense layer 9002 on plastic polarizer 9003 can be accomplished by various known methods. Reduction in thickness can be accomplished because the glass need not be patterned on both sides. Because of handling issues, glass used in LCD processes may be processed at a thickness of about 0.5 mm, for example, and then ground down to about, 0.3 mm, for example, after processing. Having circuit elements on both sides precludes grinding down the glass. However, because in the embodiment of FIG. 90 middle glass 9001 has electrodes patterned on only one side, it may be ground down, giving an overall thickness reduction of about 0.2 mm. This arrangement may include additional FPC connection 9004 to the polarizer, which can be bonded using a low temperature bonding process. An additional advantage of using a plastic substrate can arise in that materials with different dielectric constants can be used, which can provide flexibility and enhance operation of capacitive sensing circuits.

A variation on the plastic substrate embodiment is illustrated in FIG. 91. Electrodes 9101 (e.g., drive or sense lines) can be patterned on multiple plastic substrates 9102, 9103 that can then be adhered together. Because the plastic substrates can be thinner (e.g., approximately half the thickness of a glass substrate) such techniques can allow even thinner touch screens.

31

In another variation, illustrated in FIG. 92, polyester substrate 9201 can have electrodes 9202 patterned on either side. This embodiment can include an access hole 9203 through substrate 9201 for connection between the two sides. Polyester substrate 9201 can be disposed in cover 9204 of a device, such as a handheld computer. Still another variation is illustrated in FIG. 93, which illustrates a polyester layer 9301 having ITO electrodes 9302 patterned on a top surface, with access hole 9303 through substrate 9301 to a second glass substrate 9304, also with ITO electrode 9305 patterned on the top surface.

FIG. 94 illustrates an upside down view of a device, for example a handheld computer 9401. By upside down, it is meant that the user surface of the device is the bottom surface (not shown). ITO touch sensing electrodes 9402 can be patterned on the back of the user surface, with a stack up 9403 having ITO disposed on the facing surface being disposed therein during device assembly. A further variation of this concept is illustrated in FIG. 95, which shows ITO electrodes 9501 patterned on the inside of molded plastic cover 6702 and on the top of a stack up of layers 9503 according to one of the various embodiments discussed herein. In the diagram of FIG. 95, the user face of the device can be top surface 9504.

FIGS. 96, 97, and 98 illustrate a sequence of steps in manufacturing a polyester substrate having a pattern of ITO electrodes disposed thereon that may be suitable for touch sensing as described herein. FIG. 96 illustrates a patterned polyester sheet 9601 patterned into a grid of isolated squares of ITO 9602. The ITO resistivity can be about 200 ohms or less. The individual electrodes can be approximately 1 mm by 1 mm, with 30 micron gaps between. In the illustrated embodiment, sheet 9601 can be approximately 50 mm by 80 mm, which can be a suitable size for a handheld computer, multimedia player, mobile telephone, or similar device, although a variety of other sizes and/or applications will occur to those skilled in the art. As illustrated in the sectional view, the sheet may be as little as 25 microns thick, although dimensions of 25 to 200 microns may also be used. Obviously, this can provide significant advantages in terms of device thickness.

In FIG. 97, FPCs 9701 can be bonded to the patterned substrate 9702. In FIG. 98 cover 9801, which can be, for example, an approximately 0.8 mm thick layer of PMMA, can be adhered to the PET substrate 9802 using an optically clear adhesive.

3.4. Level Shifter/Decoder Integration with LCD Controller

In some embodiments, additional circuitry (active, passive, or both) can be placed in the peripheral area of the LCD (see FIG. 6) to support delivery of V_{STM} signals to the touch drive segments. Details of the peripheral area circuitry and its design rules can depend on the particular manufacturing process details and on which TFT technology (i.e., PMOS, NMOS or CMOS) is used. The following four sub-sections discuss approaches for realizing peripheral touch drive circuits in view of different drive circuit integration arrangements.

3.4.1. Discrete Level Shifter/Decoder Chip

In one approach, a discrete level shifter/decoder COG can be attached to the bottom glass (see FIG. 22). In this arrangement metal traces may be needed in the peripheral area. The number of traces can depend on the number of touch drive segments, which may be less than twenty for small displays. Design objectives of this approach can include reducing capacitive coupling, which can be affected by the spacing between touch drive traces, and the space between the touch drive traces and other LCD circuits in the peripheral area.

32

Low trace impedance can also help reduce capacitive coupling between adjacent touch drive traces.

For example, the combined resistance of the longest trace, the level shifter/decoder output resistance, the conductive dot, and the ITO drive segment may be limited to about 450 ohms. The resistance of the touch drive ITO may be around 330 ohms (assuming ITO sheet resistance of 30 ohms/sq and 11 squares), which can leave 120 ohms for other components. The following table shows one allocation of this resistance for each component in the touch drive circuit.

Level shifter/ decoder Output	Metal Trace	Conductive Dot	ITO Segment
10 ohms	100 ohms	10 ohms	330 ohms

Wider traces and/or lower sheet resistances may be used to obtain the desired trace resistance. For example, for a trace resistance of 100 ohms, a trace width of 0.18 mm or more may be desirable if the sheet resistance is 200 mohms/sq.

Of course, only the longest touch drive traces need the greatest width. Other touch drive traces, being correspondingly shorter, may have correspondingly smaller widths. For example, if the shortest trace is 5 mm, then its width could be around 0.01 mm.

FIG. 99 shows a simplified diagram of the level shifter/decoder COG 9901 for Concept A. (For Concept B, transistor Q1 and ENB_LCD[x] decoder can be eliminated.) Registered decoder block 9902 can be comprised of three separate registered decoders, which can be loaded one at a time. One of the three decoders can be selected by two signals from the Touch/LCD Driver and can be programmed using 5-bit data. The decoder outputs can control the three transistors Q1, Q2, Q3 associated with each output section of the level shifter/decoder. Each output section can be in one of three states: 1) LCD (Q1 on, Q2 and Q3 off), 2) touch (Q2 on, Q1 and Q3 off), or 3) GND (Q3 on, Q1 and Q2 off). As mentioned above, Q2's output resistance can be approximately 10 ohms or less to reduce V_{STM} phase delay. For Concept B, the LCD decoder and Q1 can be eliminated.

3.4.2. Level Shifter/Decoder Fully-Integrated in Peripheral Area

The level shifter/decoder function (FIG. 99) can also be fully integrated in the peripheral area of the bottom glass. With this approach, the type of TFT technology becomes relevant to power consumption. While CMOS TFT technology may give lower power consumption, it may be more expensive than NMOS or PMOS. However, any technology may be used depending on particular design constants.

To further reduce touch drive resistance, the transistor width may be enlarged to compensate for relatively low LTPS TFT mobility (e.g., $\sim 50 \text{ cm}^2/\text{V}\cdot\text{sec}$).

3.4.3. Level Shifter/Decoder Partially Integrated in Touch/LCD Driver

In some embodiments, the level shifter/decoder function can be partially integrated in the Touch/LCD Driver and partially integrated in the peripheral area. This approach can have several benefits including, for example, eliminating CMOS in the peripheral area, which can reduce cost, and eliminating logic in the peripheral area, which can reduce power consumption. FIG. 100 shows a modified Touch/LCD Driver 10001 and peripheral transistor circuit 10002 that can be used in this approach. The level shifter and boost circuit 10003 can be integrated on the bottom glass and positioned between the segment drivers and the Touch/LCD chip. There

can be one segment driver for each touch drive segment. Each touch drive segment can be in one of three states: GND, modulated by V_{STM} , or modulated by V_{COM} . In this arrangement level shifter circuits may be needed on the bottom glass to enable the low voltage Touch/LCD chip to control the transistor switches.

3.4.4. Level Shifter/Decoder Fully Integrated in Touch/LCD Driver

In some embodiments, the level shifter/decoder function can be completely integrated in the Touch/LCD Driver. By moving the Level shifter/decoder function to the Touch/LCD Driver, the separate level shifter/decoder COG can be eliminated. Furthermore, eliminating CMOS and logic from the peripheral area can be achieved.

FIG. 101 shows a simplified block diagram of the fully integrated Touch/LCD driver 10101, which can include the boost circuitry 10102 to generate V_{STM} . Passive components (such as capacitors, diodes, and inductors) may also be needed, but, as with all the other approaches, have not been shown for simplicity.

4. Uses, Form Factors, etc.

Exemplary applications of the integral touch screen LCD described herein will now be described. Handheld computers can be one advantageous application, including devices such as PDAs, multimedia players, mobile telephones, GPS devices, etc. Additionally, the touch screen may find application in tablet computers, notebook computers, desktop computers, information kiosks, and the like.

FIG. 102 is a perspective view of an application of a touch screen 10201, in accordance with one embodiment of the present invention. Touch screen 10201 can be configured to display a graphical user interface (GUI) including perhaps a pointer or cursor as well as other information to the user. By way of example, the touch screen may allow a user to move an input pointer or make selections on the graphical user interface by simply pointing at the GUI on the display 10202.

In general, touch screens can recognize a touch event on the surface 10204 of the touch screen and thereafter output this information to a host device. The host device may, for example, correspond to a computer such as a desktop, laptop, handheld or tablet computer. The host device can interpret the touch event and can perform an action based on the touch event. The touch screen shown in FIG. 102 can be configured to recognize multiple touch events that occur at different locations on the touch sensitive surface 10204 of the touch screen at the same time. As shown, the touch screen can, for example, generate separate tracking signals S1-S4 for each touch point T1-T4 that occurs on the surface of the touch screen at a given time.

The multiple touch events can be used separately or together to perform singular or multiple actions in the host device. When used separately, a first touch event may be used to perform a first action while a second touch event may be used to perform a second action that can be different than the first action. The actions may, for example, include moving an object such as a cursor or pointer, scrolling or panning, adjusting control settings, opening a file or document, viewing a menu, making a selection, executing instructions, operating a peripheral device connected to the host device etc. When used together, first and second touch events may be used for performing one particular action. The particular action may for example include logging onto a computer or a computer network, permitting authorized individuals access to restricted areas of the computer or computer network, loading a user profile associated with a user's preferred arrangement

of the computer desktop, permitting access to web content, launching a particular program, encrypting or decoding a message, and/or the like.

Referring back to FIG. 102, touch screen 10201 may be a stand alone unit or may integrate with other devices. When stand alone, touch screen 10201 can act like a peripheral device (e.g., a monitor) that can include its own housing. A stand alone display arrangement can be coupled to a host device through wired or wireless connections. When integrated, touch screen 10201 can share a housing and can be hard wired into the host device, thereby forming a single unit. By way of example, the touch screen 10201 may be disposed inside a variety of host devices including but not limited to general purpose computers such as a desktop, laptop or tablet computers, handhelds such as PDAs and media players such as music players, or peripheral devices such as cameras, printers, mobile telephones, and/or the like.

FIG. 103 is a block diagram of a computer system 10301, in accordance with one embodiment of the present invention. Computer system 10301 may correspond to personal computer systems such as desktops, laptops, tablets or handhelds. By way of example, the computer system may correspond to any Apple or PC-based computer system. The computer system may also correspond to public computer systems such as information kiosks, automated teller machines (ATM), point of sale machines (POS), industrial machines, gaming machines, arcade machines, vending machines, airline e-ticket terminals, restaurant reservation terminals, customer service stations, library terminals, learning devices, and the like.

As shown, computer system 10301 can include processor 56 configured to execute instructions and to carry out operations associated 10302 computer system 10301. For example, using instructions retrieved for example from memory, processor 10302 may control the reception and manipulation of input and output data between components of computing system 10301. Processor 10302 can be a single-chip processor or can be implemented with multiple components.

In most cases, processor 10302 together with an operating system operates to execute computer code and produce and use data. The computer code and data may reside within program storage block 10303 that can be operatively coupled to processor 10302. Program storage block 10303 can provide a place to hold data being used by computer system 10301. By way of example, the program storage block may include read-only memory (ROM) 10304, random-access memory (RAM) 10305, hard disk drive 10306, and/or the like. The computer code and data could also reside on a removable storage medium and loaded or installed onto the computer system when needed. Removable storage media can include, for example, CD-ROM, PC-CARD, floppy disk, magnetic tape, and a network component.

Computer system 10301 can also include an input/output (I/O) controller 10307 that can be operatively coupled to processor 10302. I/O controller 10307 may be integrated with processor 56 or it may be a separate component as shown. I/O controller 10307 can be configured to control interactions with one or more I/O devices. I/O controller 66 can operate by exchanging data between the processor and the I/O devices that desire to communicate with the processor. The I/O devices and the I/O controller can communicate through data link 10312. Data link 10312 may be a one way link or two way link. In some cases, I/O devices may be connected to I/O controller 10307 through wired connections. In other cases, I/O devices may be connected to I/O controller 10307 through

wireless connections. By way of example, data link **10312** may correspond to PS/2, USB, Firewire, IR, RF, Bluetooth, or the like.

Computer system **10301** can also include display device **10308**, e.g., an integral touch screen LCD as described herein, that can be operatively coupled to processor **10302**. Display device **10308** may be a separate component (peripheral device) or may be integrated with the processor and program storage to form a desktop computer (all in one machine), a laptop, handheld or tablet or the like. Display device **10308** can be configured to display a graphical user interface (GUI) including, for example, a pointer or cursor as well as other information displayed to the user.

Display device **10308** can also include an integral touch screen **10309** (shown separately for clarity, but actually integral with the display) that can be operatively coupled to the processor **10302**. Touch screen **10309** can be configured to receive input from a user's touch and to send this information to processor **10302**. Touch screen **10309** can recognize touches and the position, shape, size, etc. of touches on its surface. Touch screen **10309** can report the touches to processor **10302**, and processor **10302** can interpret the touches in accordance with its programming. For example, processor **10302** may initiate a task in accordance with a particular touch.

The touch screen LCDs described herein may find particularly advantageous application in multi-functional handheld devices such as those disclosed in U.S. patent application Ser. No. 11/367,749, entitled "Multi-functional Hand-held Device", filed Mar. 3, 2006, which is hereby incorporated by reference.

For example, principles described herein may be used to devise input devices for a variety of electronic devices and computer systems. These electronic devices and computer system may be any of a variety of types illustrated in FIG. **104**, including desktop computers **10401**, notebook computers **10402**, tablet computers **10403**, handheld computers **10404**, personal digital assistants **10405**, media players **10406**, mobile telephones **10407**, and the like. Additionally, the electronic devices and computer systems may be combinations of these types, for example, a device that is a combination of personal digital assistant, media player and mobile telephone. Other alternations, permutations, and combinations of the aforementioned embodiments are also possible.

Moreover, the principles herein, though described with reference to capacitive multi-touch systems, may also apply to systems in which touch or proximity sensing depends on other technologies. It is therefore intended that the following claims be interpreted as including all alterations, permutations, combinations and equivalents of the foregoing.

What is claimed is:

1. An integrated liquid crystal display touch screen comprising:

- a first polarizer;
- a second polarizer;
- a first substrate having display control circuitry formed thereon, the first substrate being disposed between the first polarizer and the second polarizer;
- a second substrate disposed between the first polarizer and the second polarizer and adjacent the first substrate;
- a liquid crystal layer disposed between the first and second substrates;
- a plurality of touch sensing elements disposed between the first and second polarizers and not between the first and second substrates, the plurality of touch sensing elements comprising a plurality of touch drive electrodes and a plurality of touch sense electrodes, the plurality of

touch drive electrodes and the plurality of touch sense electrodes being operative at least during a touch sensing mode of operation;

the plurality of touch drive electrodes and the plurality of touch sense electrodes spaced apart from one another to form capacitive coupling nodes therebetween;

a counter electrode used during a liquid crystal display operation and disposed between the liquid crystal layer and the second substrate, the counter electrode separate and distinct from the plurality of touch drive electrodes and separate and distinct from the plurality of touch sense electrodes;

the counter electrode being grounded during the touch sensing mode of operation to shield the plurality of touch drive electrodes and the plurality of touch sense electrodes disposed above the counter electrode, from the liquid crystal layer disposed below the counter electrode;

the plurality of touch drive electrodes operative to receive a periodic voltage;

the plurality of touch drive electrodes driven by the periodic voltage one at a time or in groups; and
at least one capacitance sensing circuit operatively coupled to the plurality of touch sense electrodes during the touch sensing mode of operation for measuring a change in current and/or voltage resulting from a change in capacitance at the capacitive coupling nodes.

2. The touch screen of claim 1 wherein the second substrate has a color filter disposed thereon.

3. The touch screen of claim 2 wherein the color filter is formed on a side of the second substrate facing the liquid crystal layer, and wherein the plurality of touch sensing elements are formed on the second substrate on a side opposite that of the color filter.

4. The touch screen of claim 3 wherein the plurality of touch sensing elements further comprise:

a first plurality of touch electrodes formed on the second substrate, the first plurality of touch electrodes being one of the plurality of touch drive or the plurality of touch sense electrodes;

a dielectric deposited over the first plurality of electrodes; and

a second plurality of touch electrodes formed on top of the dielectric, the second plurality of touch electrodes being the other of the plurality of touch drive or the plurality of touch sense electrodes.

5. The touch screen of claim 4 wherein the first plurality of touch electrodes formed on the second substrate comprises ITO patterned to form the plurality of touch drive electrodes or the plurality of touch sense electrodes.

6. The touch screen of claim 4 wherein the plurality of touch drive electrodes are driven by the periodic voltage one at a time or in groups while the non-driven touch drive electrodes are grounded.

7. The touch screen of claim 1 wherein the plurality of touch drive electrodes are driven by the periodic voltage one at a time or in groups while the non-driven touch drive electrodes are grounded.

8. The touch screen of claim 1 wherein the second substrate is glass.

9. The touch screen of claim 1 wherein the second substrate is plastic.

10. The touch screen of claim 1 wherein the plurality of touch sensing elements comprises a mutual capacitance touch-sensing arrangement.

37

11. The electronic device of claim 10, wherein the first substrate further comprises touch control circuitry; and the touch screen further comprises an electrical connector electrically connecting the touch control circuitry on the first substrate to the top surface of the second substrate. 5

12. The electronic device of claim 11, wherein the electrical connector comprises a flexible printed circuit.

13. The electronic device of claim 11 wherein the electrical connector comprises a first flexible printed circuit connecting the plurality of touch sense electrodes to the touch control circuitry and a second flexible printed circuit connecting the plurality of touch drive electrodes to the touch control circuitry. 10

14. The touch screen of claim 1, wherein the first substrate further comprises touch control circuitry; and the touch screen further comprises an electrical connector electrically connecting the touch control circuitry on the first substrate to the top surface of the second substrate. 15

15. The touch screen of claim 14, wherein the electrical connector comprises a flexible printed circuit. 20

16. The touch screen of claim 14 wherein the electrical connector comprises a first flexible printed circuit connecting the plurality of touch sense electrodes to the touch control circuitry and a second flexible printed circuit connecting the plurality of touch drive electrodes to the touch control circuitry. 25

17. An electronic device incorporating an integrated liquid crystal display touch screen, wherein the liquid crystal display touch screen comprises: 30

a first polarizer;

a second polarizer;

a first substrate having display control circuitry formed thereon, the first substrate being disposed between the first polarizer and the second polarizer; 35

a second substrate disposed between the first polarizer and the second polarizer and adjacent the first substrate;

a liquid crystal layer disposed between the first and second substrates; 40

a plurality of touch sensing elements disposed between the first and second polarizers and not between the first and second substrates, the plurality of touch sensing elements comprising a plurality of touch drive electrodes and a plurality of touch sense electrodes, the plurality of touch drive electrodes and the plurality of touch sense electrodes being operative at least during a touch sensing mode of operation; 45

the plurality of touch drive electrodes and the plurality of touch sense electrodes spaced apart from one another to form capacitive coupling nodes therebetween; 50

a counter electrode used during a liquid crystal display operation and disposed between the liquid crystal layer and the second substrate, the counter electrode separate and distinct from the plurality of touch drive electrodes and separate and distinct from the plurality of touch sense electrodes; 55

the counter electrode being grounded during the touch sensing mode of operation to shield the plurality of touch drive electrodes and the plurality of touch sense electrodes disposed above the counter electrode, from the liquid crystal layer disposed below the counter electrode; 60

the plurality of touch drive electrodes operative to receive a periodic voltage;

the plurality of touch drive electrodes driven by the periodic voltage one at a time or in groups; and 65

38

at least one capacitance sensing circuit operatively coupled to the plurality of touch sense electrodes during the touch sensing mode of operation for measuring a change in current and/or voltage resulting from a change in capacitance at the capacitive coupling nodes.

18. The electronic device of claim 17 wherein a color filter is formed on a side of the second substrate facing the liquid crystal layer, and wherein the plurality of touch sensing elements are formed on the second substrate on a side opposite that of the color filter. 10

19. The electronic device of claim 18,

wherein the plurality of touch drive electrodes are driven by the periodic voltage one at a time or in groups while the non-driven touch drive electrodes are grounded.

20. The electronic device of claim 19 wherein the plurality of touch sensing elements further comprise: 15

a first plurality of touch electrodes formed on the second substrate, the first plurality of touch electrodes being one of the plurality of touch drive or the plurality of touch sense electrodes;

a dielectric deposited over the first plurality of electrodes; and

a second plurality of touch electrodes formed on top of the dielectric, the second plurality of touch electrodes being the other of the plurality of touch drive or the plurality of touch sense electrodes. 20

21. The electronic device of claim 20 wherein the electronic device comprises at least one of a handheld computer, a personal digital assistant, a media player, a mobile telephone, a desktop computer, a tablet computer, and a notebook computer. 25

22. The electronic device of claim 18 wherein the plurality of touch sensing elements further comprise: 30

a first plurality of touch electrodes formed on the second substrate, the first plurality of touch electrodes being one of the plurality of touch drive or the plurality of touch sense electrodes;

a dielectric deposited over the first plurality of electrodes; and

a second plurality of touch electrodes formed on top of the dielectric, the second plurality of touch electrodes being the other of the plurality of touch drive or the plurality of touch sense electrodes. 35

23. The electronic device of claim 17 wherein the one or more touch sensors formed on the second substrate further comprise: 40

a first plurality of touch electrodes formed on the second substrate, the first plurality of touch electrodes being one of the plurality of touch drive or touch sense electrodes; a dielectric deposited over the first plurality of electrodes; and

a second plurality of touch electrodes formed on top of the dielectric, the second plurality of touch electrodes being the other of the plurality of touch drive or touch sense electrodes. 45

24. The electronic device of claim 23 wherein the electronic device is selected from the group consisting of a desktop computer, a tablet computer, and a notebook computer. 50

25. The electronic device of claim 23 wherein the electronic device comprises at least one of a handheld computer, a personal digital assistant, a media player, and a mobile telephone. 55

26. The electronic device of claim 23 wherein the first plurality of touch electrodes formed on the second substrate comprises ITO patterned to form the plurality of touch drive electrodes. 60

39

27. The electronic device of claim 26 wherein the electronic device is selected from the group consisting of a desktop computer, a tablet computer, and a notebook computer.

28. The electronic device of claim 26 wherein the electronic device comprises at least one of a handheld computer, a personal digital assistant, a media player, and a mobile telephone.

29. The electronic device of claim 23 wherein the first plurality of touch electrodes formed on the second substrate comprises ITO patterned to form the plurality of touch sense electrodes.

30. The electronic device of claim 29 wherein the electronic device is selected from the group consisting of a desktop computer, a tablet computer, and a notebook computer.

31. The electronic device of claim 29 wherein the electronic device comprises at least one of a handheld computer, a personal digital assistant, a media player, and a mobile telephone.

32. The electronic device of claim 17 wherein the plurality of touch drive electrodes are driven by the periodic, voltage one at a time or in groups while the non-driven touch drive electrodes are grounded.

33. The electronic device of claim 32 wherein the electronic device is selected from the group consisting of a desktop computer, a tablet computer, a notebook computer, a handheld computer, a personal digital assistant, a media player, and a mobile telephone.

34. A mobile telephone incorporating an integrated liquid crystal display touch screen, wherein the liquid crystal display touch screen comprises:

a first polarizer;

a second polarizer;

a first substrate having display control circuitry formed thereon, the first substrate being disposed between the first polarizer and the second polarizer;

a second substrate disposed between the first polarizer and the second polarizer and adjacent the first substrate;

a liquid crystal layer disposed between the first and second substrates;

a plurality of touch sensing elements disposed between the first and second polarizers and not between the first and second substrates, the plurality of touch sensing elements comprising a plurality of touch drive electrodes and plurality of touch sense electrodes, the plurality of touch drive electrodes and the plurality of touch sense electrodes being operative at least during a touch sensing mode of operation;

40

the plurality of touch drive electrodes and the plurality of touch sense electrodes spaced apart from one another to form capacitive coupling nodes therebetween;

a counter electrode used during a liquid crystal display operation and disposed between the liquid crystal layer and the second substrate, the counter electrode separate and distinct from the plurality of touch drive electrodes and separate and distinct from the plurality of touch sense electrodes;

the counter electrode being grounded during the touch sensing mode of operation to shield the plurality of touch drive electrodes and the plurality of touch sense electrodes disposed above the counter electrode, from the liquid crystal layer disposed below the counter electrode;

the plurality of touch drive electrodes operative to receive a periodic voltage;

the plurality of touch drive electrodes driven by the periodic voltage one at a time or in groups; and

at least one capacitance sensing circuit operatively coupled to the plurality of touch sense electrodes during the touch sensing mode of operation for measuring a change in current and/or voltage resulting from a change in capacitance at the capacitive coupling nodes.

35. The mobile telephone of claim 34 wherein the color filter is formed on a side of the second substrate facing the liquid crystal layer, and wherein the plurality of touch sensing elements are formed on the second substrate on a side opposite that of the color filter.

36. The mobile telephone of claim 34 wherein the plurality of touch sensing elements further comprise: a first plurality of touch electrodes formed on the second substrate, the first plurality of touch electrodes being one of the plurality of touch drive or the plurality of touch sense electrodes;

a dielectric deposited over the first plurality of electrodes; and

a second plurality of touch electrodes formed on top of the dielectric, the second plurality of touch electrodes being the other of the plurality of touch drive or the plurality of touch sense electrodes.

37. The mobile telephone of claim 34 wherein the plurality of touch drive electrodes are driven by the periodic voltage one at a time or in groups while the non-driven touch drive electrodes are grounded.

* * * * *

UNITED STATES PATENT AND TRADEMARK OFFICE
CERTIFICATE OF CORRECTION

PATENT NO. : 8,259,078 B2
APPLICATION NO. : 11/760036
DATED : September 4, 2012
INVENTOR(S) : Steve Porter Hotelling et al.

Page 1 of 2

It is certified that error appears in the above-identified patent and that said Letters Patent is hereby corrected as shown below:

In the Abstract, line 5, delete “but outside the not between” and enter --outside (not between)--, therefore.

At column 37, claim number 11, line number 4, delete “connect r” and enter --connector--, therefore.

At column 37, claim 12, line numbers 7-8, delete “electrically” and enter --electrical--, therefore.

At column 37, claim 13, line 9, delete “d vice” and enter --device--, therefore.

At column 37, claim 13, line 12, delete “printed, circuit” and enter --printed circuit--, therefore.

A column 37, claim 14, line 18, delete “connect r” and enter --connector--, therefore.

At column 37, claim 15, line 21, delete “electrically” and enter --electrical--, therefore.

At column 38, claim 17, line 1, delete “sensing, circuit” and enter --sensing circuit--, therefore.

At column 38, claim 23, line 55, delete “3. lurality” and enter --plurality--, therefore.

At column 38, claim 24, line 59, delete “Computer” and enter --computer--, therefore.

At column 39, claim 32, line 20, delete “periodic, voltage” and enter --periodic voltage--, therefore.

At column 40, claim 34, line 22, delete “m ode” and enter --mode--, therefore.

Signed and Sealed this
Eighth Day of January, 2013

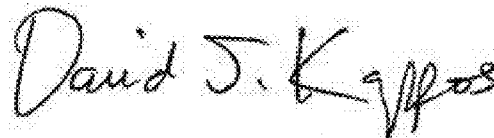

David J. Kappos
Director of the United States Patent and Trademark Office

CERTIFICATE OF CORRECTION (continued)

U.S. Pat. No. 8,259,078 B2

At column 40, claim 35, line 28, delete “he” and enter --the--, therefore.

At column 40, claim 36, line 31, delete “first st plurality” and enter --first plurality--, therefore.

At column 40, claim 36, line 33, delete “el ctrodes” and enter --electrodes--, therefore.